



**Wanyou Fire Safety Technology Holdings Limited**

**萬友消防科技控股有限公司**

*(Incorporated in the Cayman Islands with limited liability)*

# Placing of Shares

Sponsor



**Core Pacific - Yamaichi Capital Limited**

Joint Global Coordinators



**Core Pacific - Yamaichi Capital Limited**



**ICEA**

**ICEA Capital Limited**

Joint Lead Managers



**ICEA**

**ICEA Capital Limited**



**Core Pacific - Yamaichi  
International (H.K.) Limited**

# IMPORTANT

If you are in any doubt about this prospectus, you should consult your stockbroker, bank manager, solicitor, professional accountant or other professional adviser.



## Wanyou Fire Safety Technology Holdings Limited 萬友消防科技控股有限公司

(Incorporated in the Cayman Islands with limited liability)

### LISTING ON THE GROWTH ENTERPRISE MARKET OF THE STOCK EXCHANGE OF HONG KONG LIMITED

#### PLACING OF SHARES

Number of Placing Shares	:	500,000,000 Shares comprising 400,000,000 New Shares and 100,000,000 Sale Shares (subject to the Over-allotment Option)
Issue Price	:	HK\$0.40 per Share
Nominal Value	:	HK\$0.01 each
Stock Code	:	8201

#### Sponsor



Core Pacific - Yamaichi Capital Limited

Joint Global Coordinators



Core Pacific - Yamaichi Capital Limited

Joint Lead Managers



A subsidiary of ICBC

ICEA Capital Limited



A subsidiary of ICBC

ICEA Capital Limited



Core Pacific - Yamaichi  
International (H.K.) Limited

#### Co-Managers

CLSA Emerging Markets  
Nomura International (Hong Kong) Limited  
Sun Hung Kai International Limited

Karl-Thomson Securities Company Limited  
Phoenix Capital Securities Limited  
The Bank of East Asia, Limited

The Stock Exchange of Hong Kong Limited and Hong Kong Securities Clearing Company Limited take no responsibility for the contents of this prospectus, make no representation as to its accuracy or completeness and expressly disclaim any liability whatsoever for any loss howsoever arising from or in reliance upon the whole or any part of the contents of this prospectus.

A copy of this prospectus, having attached thereto the documents specified in the paragraph headed "Documents delivered to the Registrar of Companies and available for inspection" in Appendix V to this prospectus, has been registered by the Registrar of Companies in Hong Kong as required by section 342C of the Companies Ordinance, Chapter 32 of the Laws of Hong Kong. The Securities and Futures Commission and the Registrar of Companies in Hong Kong take no responsibility as to the contents of this prospectus or any other documents referred to above.

Prospective investors of the Placing Shares should note that the Underwriters are entitled to terminate their obligations under the Underwriting Agreement by notice in writing to the Company given by CPY International and ICEA (for themselves and on behalf of the Underwriters), acting as the joint lead managers of the Placing, upon the occurrence of any of the events set forth under "Grounds for termination" in the section headed "Underwriting" in this prospectus at any time prior to 4:00 p.m. (Hong Kong time) on 27th September, 2002. Such events include, but without limitation to, any act of God, war, riot, public disorder, civil commotion, or terrorism.

23rd September, 2002

## **CHARACTERISTICS OF THE GEM**

The GEM has been established as a market designed to accommodate companies to which a high investment risk may be attached. In particular, companies may list on the GEM with neither a track record of profitability nor any obligation to forecast future profitability. Furthermore, there may be risks arising out of the emerging nature of companies listed on the GEM and the business sectors or countries in which the companies operate. Prospective investors should be aware of the potential risks of investing in such companies and should make the decision to invest only after due and careful consideration. The greater risk profile and other characteristics of the GEM mean that it is a market more suited to professional and other sophisticated investors.

Given the emerging nature of companies listed on the GEM, there is a risk that securities traded on the GEM may be more susceptible to high market volatility than securities traded on the Main Board and no assurance is given that there will be a liquid market in the securities traded on the GEM.

The principal means of information dissemination on the GEM is publication on the Internet website operated by the Stock Exchange. Listed companies are not generally required to issue paid announcements in gazetted newspapers. Accordingly, prospective investors should note that they need to have access to the GEM website at <http://www.hkgem.com> in order to obtain up-to-date information on the GEM-listed issuers.

# EXPECTED TIMETABLE

2002

Announcement of the level of indication of interest in the Placing to be published on the GEM website at <i>www.hkgem.com</i> on .....	27th September
Deposit of share certificates into CCASS on ( <i>Note 1</i> ) .....	27th September
Allocation to placees on .....	27th September
Dealings in the Shares on the GEM to commence on or about .....	30th September

*Notes:*

- (1) The share certificate(s) for the Placing Shares to be distributed through CCASS is/are expected to be deposited into CCASS on 27th September, 2002 for credit to the respective CCASS participants' stock accounts designated by the Underwriters, the placees or their agents, as the case may be, but will only become valid certificates of title at 4:00 p.m., on 27th September, 2002 provided that (i) the Placing has become unconditional in all respects and (ii) the right of termination as described in the section headed "Underwriting" has not been exercised. No temporary documents of title will be issued.
- (2) For details of the structure of the Placing, including the conditions thereto, see the section headed "Structure and conditions of the Placing" in this prospectus.
- (3) In the event of any change to the expected timetable as set out in this prospectus, an announcement will be made accordingly.
- (4) All times refer to Hong Kong local time.

# CONTENTS

*You should rely only on the information contained in this prospectus to make your investment decision.*

*The Company has not authorised anyone to provide you with information that is different from what is contained in this prospectus.*

*Any information or representation not made nor contained in this prospectus must not be relied on by you as having been authorised by the Company, the Sponsor, the Underwriters, any of their respective directors or any other person involved in the Placing.*

*The contents of the website mentioned in this prospectus do not form part of this prospectus.*

	<i>Page</i>
<b>Characteristics of the GEM</b> .....	i
<b>Expected timetable</b> .....	ii
<b>Summary</b> .....	1
<b>Definitions</b> .....	15
<b>Glossary of technical terms</b> .....	20
<b>Risk factors</b>	
Risks relating to the Group .....	21
Risks relating to the industry .....	25
Risks relating to the PRC .....	26
Issues relating to statements made in this prospectus .....	28
<b>Information about this prospectus and the Placing</b> .....	29
<b>Directors and parties involved in the Placing</b> .....	33
<b>Corporate information</b> .....	36
<b>Industry overview</b> .....	37

# CONTENTS

	<i>Page</i>
<b>General overview of the Group</b>	
Group structure .....	46
History and active business pursuit .....	48
Description of business .....	56
Business model of the Group	
I. <i>Product Sales</i>	
Products .....	58
Description of operation .....	59
Pricing policy .....	60
Sales and marketing .....	60
Production facilities .....	64
Production process .....	64
Purchase and procurement .....	65
Quality control .....	66
Inventory control .....	66
Repair and maintenance .....	66
II. <i>Installation Services</i>	
Project tendering .....	68
Project management .....	68
Procurement of parts .....	69
Quality control .....	69
Payment terms .....	70
III. <i>Maintenance Services</i> .....	70
Insurance .....	71
After-sale and after installation services .....	71
Research and development .....	71
Intellectual property rights .....	73
Competition and competitive strength .....	73
Awards and certifications .....	76
Strategic Investors .....	79
Competing Interests .....	81
Related party transactions .....	82
<b>Statement of business objectives</b>	
The Group's mission .....	83
Bases and assumptions .....	83
Market potential .....	84
Objectives of the Group .....	85
Use of proceeds .....	102
<b>Directors, senior management and employees</b>	
Directors .....	105
Senior management .....	106
Company secretary and qualified accountant .....	106
Compliance officer .....	107
Audit committee .....	107
Staff .....	107
The Group's relationship with staff .....	108
Directors' remuneration policy .....	108
Pension Scheme .....	108
Share Option Scheme .....	108

# CONTENTS

	<i>Page</i>
<b>Substantial shareholder, initial management shareholder, significant shareholder and other shareholders</b>	
Substantial Shareholder .....	109
Initial Management Shareholder .....	109
Significant Shareholder .....	109
Other Shareholders .....	110
Undertakings .....	110
Further undertakings .....	111
<b>Share capital</b> .....	113
<b>Financial information</b>	
Indebtedness .....	115
Capital structure, financial resources and liquidity .....	116
Property .....	116
Trading record .....	117
Management discussion and analysis .....	118
Distributable reserves .....	125
Working capital .....	125
Adjusted net tangible assets .....	126
No material adverse change .....	126
<b>Underwriting</b>	
Underwriters .....	127
Underwriting arrangements and expenses .....	127
<b>Structure and conditions of the Placing</b>	
Price payable on subscription .....	132
Placing .....	132
Conditions of the Placing .....	132
Over-allotment Option .....	133
Stabilisation .....	133
<b>Appendix I – Accountants’ report</b> .....	I – 1
<b>Appendix II – Property valuation</b> .....	II – 1
<b>Appendix III – Summary of the constitution of the Company and Cayman Islands Company Law</b> .....	III – 1
<b>Appendix IV – Statutory and general information</b> .....	IV – 1
<b>Appendix V – Documents delivered to the Registrar of Companies and available for inspection</b> .....	V – 1

# SUMMARY

*This summary aims to give you an overview of the information contained in this prospectus. As this is a summary, it does not contain all the information that may be important to you. You should read the whole document before you decide to invest in the Placing Shares.*

*There are risks associated with any investment, some of the particular risks in investing in the Placing Shares are set out in the section headed "Risk factors" in this prospectus. You should read that section carefully before you decide to invest in the Placing Shares.*

## GENERAL OVERVIEW OF THE GROUP

The Group is a total solution provider of fire prevention and fighting systems in the PRC, specialising in system design, development, manufacturing, sales, installation and maintenance. For the two years ended 31st December, 2001 and for the seven months ended 31st July, 2002, Product Sales accounted for approximately 84%, 74% and 61% respectively, Installation Services accounted for approximately 16%, 25% and 35% respectively, and Maintenance Services accounted for approximately nil, 1% and 4% respectively, of the Group's turnover.

According to the CFPA, there are only a few companies in the fire prevention and fighting industry in the PRC that have integrated operations in the design, manufacturing, installation and maintenance of fire prevention and fighting systems. The Directors believe that such integrated operations have created synergy for the Group. In addition, the integrated scope of operation enables the Group to cross-sell its products and services to customers and fully capture realisable revenues at both ends. Therefore, the Directors believe that the integrated operations is one of the reasons for the Group to have recorded a remarkable profit margin and outstanding track record.

The Group has 16 registered patents on fire prevention and fighting equipment in the PRC and has obtained Certificates of Conformity of Product Quality (產品質量認證證書) issued by CCCFP for all of its fire prevention and fighting equipment. The certificates are compulsory for all fire prevention and fighting equipment manufacturers in the PRC. Since the Group's fire prevention and fighting products received wide recognition in the market, the National Quality and Technology Supervision Bureau (國家質量技術監督局) has invited the Group to participate in formulating the national standard of fire emergency luminaries in the PRC.

For the seven months ended 31st July, 2002, the turnover generated by Product Sales before the provision of sales tax amounted to approximately RMB90 million, the breakdown of which is as follows:

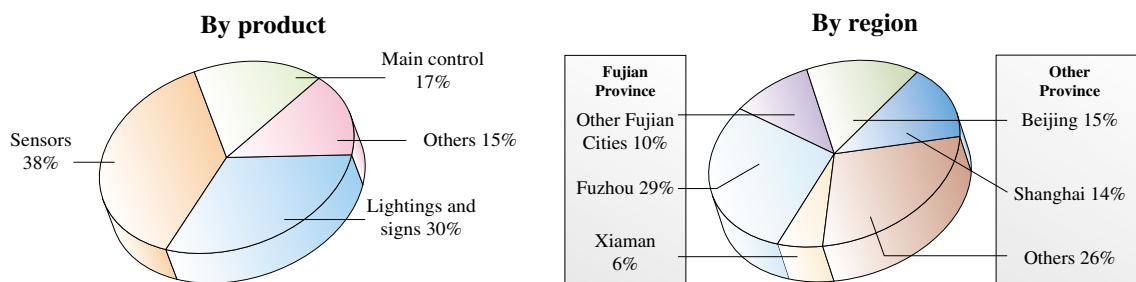



# SUMMARY

For the year ended 31st December, 2001, the turnover generated by Product Sales before the provision of sales tax amounted to approximately RMB146 million, the breakdown of which is as follows:

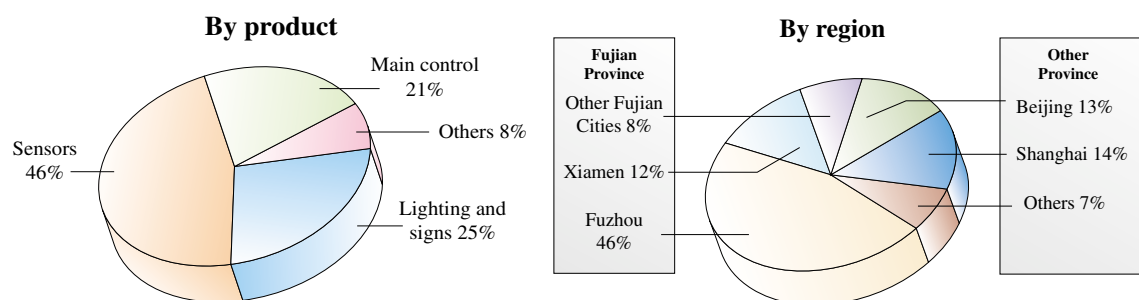

For the year ended 31st December, 2000, the turnover generated by Product Sales before the provision of sales tax amounted to approximately RMB72 million, the breakdown of which is as follows:

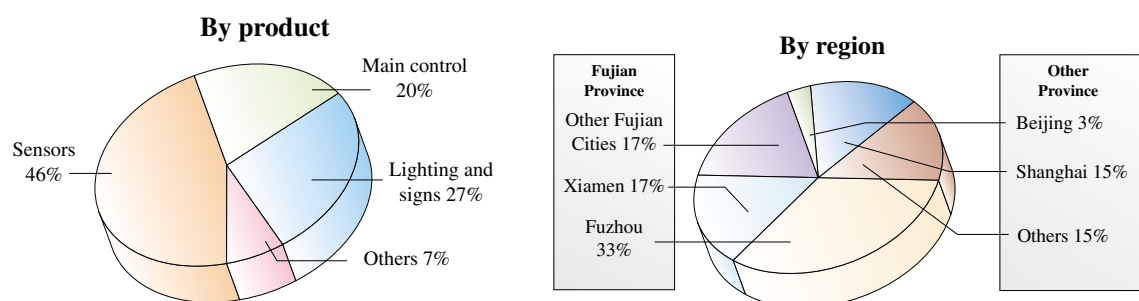

The Group has obtained a Class 1 license in 2000 for fire prevention and fighting equipment installation and has been authorised to render fire prevention and fighting equipment installation to all building projects including, but not limited to, commercial, residential, industrial, government and public sector projects. The Class 1 license was replaced by 消防設施工程專業承包一級資質證書 (Class I Certificate for contractors of professional fire prevention and fighting systems installation) in June 2002. As at 31st July, 2002, the Group has (i) completed 63 projects, including Fuzhou Changle International Airport (福州長樂國際機場), Chingkou Vehicle City of Dongnan Automobiles (東南汽車城) and Fuzhou Fire Services Control Centre (福州消防指揮中心); and (ii) participated in about 14 ongoing projects in Fujian Province which are expected to be completed by the end of 2002.

For the seven months ended 31st July, 2002, the turnover generated by Installation Services before the provision of sales tax amounted to approximately RMB53 million, the breakdown of which is set out as follows:

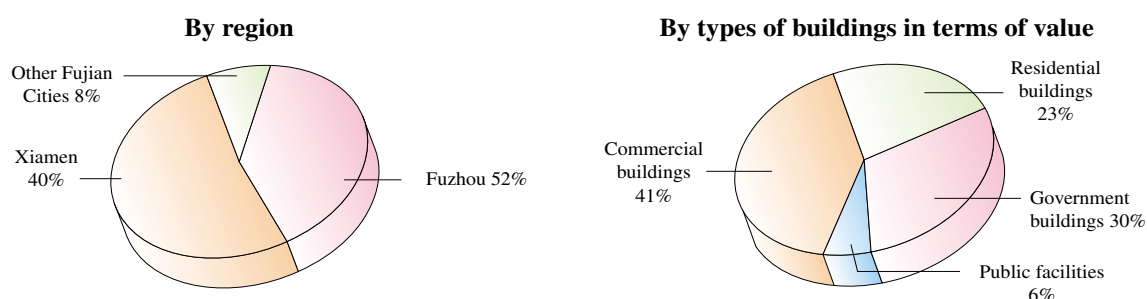

# SUMMARY

For the year ended 31st December, 2001, the turnover generated by Installation Services before the provision of sales tax amounted to approximately RMB50 million, the breakdown of which is set out as follows:

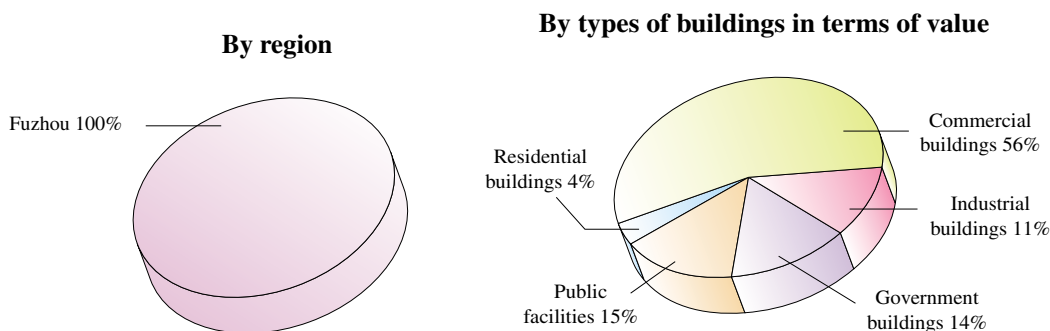

For the year ended 31st December, 2000, the turnover generated by Installation Services before the provision of sales tax amounted to approximately RMB14 million, the breakdown of which is set out as follows:

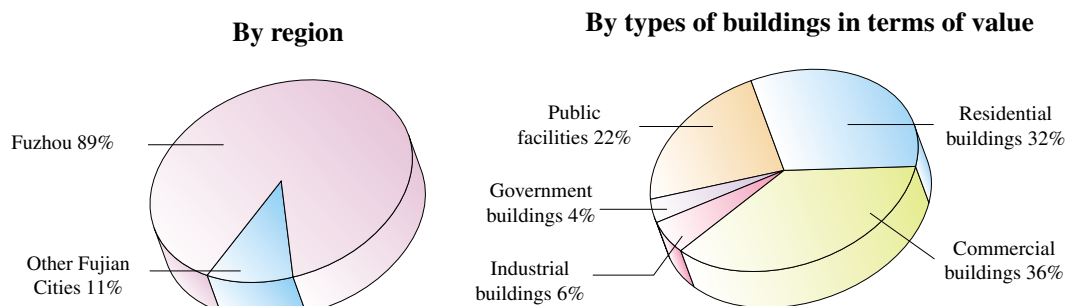

In March 2001, the Group was approved as an authorised maintenance services provider of fire prevention and fighting systems by the Fujian Province General Bureau of Fire Services (福建省公安消防總隊). As the Group did not commence the Maintenance Services until June 2001, the turnover generated from such business before the provision of sales tax amounted to approximately RMB2.6 million for the year ended 31st December, 2001 and approximately RMB7.3 million for the seven months ended 31st July, 2002. The Directors believe that the turnover generated by Maintenance Services will increase substantially in the coming years given the lack of competition and the tightening of the enforcement of fire prevention laws and regulations.

## PRINCIPAL STRENGTHS

The Directors believe that the Group has the following competitive advantages over its competitors:

### 1. Integrated scope of business

According to CFPA's information, there are only a few companies in the PRC that have a full array of licenses to operate integrated business in the design, manufacturing, installation and maintenance of fire prevention and fighting systems, which the Directors believe the Group is one of them. The Directors consider that the provision of Installation Services enables the Group to accumulate information and learn about market demands, which is favourable for the development of the Group's products. On the other hand, the design and manufacturing capability of the Group provide it with competitive advantage in the Installation Services.

# SUMMARY

## 2. Emphasis on research and development

The Group places strong emphasis on research and development and has formed an experienced team in the PRC to conduct research and development. In addition, the Group engages research and academic institutions such as Research Institute of Fuzhou University (福州大學科技開發總公司) (“Fuzhou Research Institute”) and Shenyang Research Institute on Fire Prevention and Fighting Technology under the Ministry of Public Security (公安部瀋陽消防科學研究所) (“Shenyang Research Institute”) to undertake research and development projects. Such co-operation allows the Group to capitalise on the specialised knowledge in fire prevention and fighting products. Currently, the Group is devoted to the improvement of the quality and functionality of the control station of fire alarm system; in particular, the compatibility of the Group’s fire alarm system with the sensors of the majority of fire alarm system manufacturers. The Directors believe that through research and development, the Group will be able to increase its market share and maintain profit margin on a technology driven basis.

## 3. Established reputation and product recognition

The Group has been engaged in the fire prevention and fighting products industry since 1995 and has built a reputation in the PRC for delivering high quality fire prevention and fighting products. The Group’s products are sold in major cities in the PRC, namely, Fuzhou, Beijing and Shanghai. In addition, owing to the recognition by National Quality and Technology Supervision Bureau (國家質量技術監督局) of the Group’s fire prevention and fighting products, the Group has been invited to participate in the formulation of the national standard of fire emergency luminaries in the PRC.

## 4. Protection by patents

The Group has obtained 16 patents on its fire prevention and fighting equipment in the PRC. As the production of fire prevention and fighting systems require Certificates of Conformity of Product Quality (產品質量認證證書) issued by CCCFP under the Ministry of Public Security, any patent infringing equipment from other manufacturers will not be granted such certificate and sales of such infringing products are prohibited.

## 5. Effective and extensive distribution network

The Group’s Product Sales are extensively dispersed all over the PRC. The Group has established a nation wide distribution network mainly maintained by the Group’s 16 branch offices as well as 17 distributors in major cities in the PRC. The well established network provides effective means for the Group to capitalise on its research and development capacity and management efficiency to magnify its market shares.

## 6. Focused and experienced management

The Group’s management team members, in particular, Mr. Jiang Xiong and Mr. Jiang Qing, are highly specialised and experienced in the fire prevention and fighting systems and equipment business. The continuity, in-depth expertise and experience of the Group’s management team enable the Group to compete in the industry effectively and efficiently.

# SUMMARY

## 7. Well-established relationship with relevant authorities

Apart from building its professional capability, the Group has also established relationships with various parties including the relevant fire services departments, organisations and property developers. The Group has been invited by Fujian Province General Bureau of Fire Services (福建省公安消防總隊) to participate in fire alarm system promotional and introductory programmes. The Directors believe that such well-established relationships benefit the Group in terms of building up reputation, and better access to the latest industrial information and know-how.

## 8. Favourable foundation for future development

The Directors believe that the fire service equipment market in the PRC is enormous. In particular, the fire service departments at all levels in the PRC purchase fire prevention and fighting equipment and fire services supplies for approximately RMB3 billion each year. The Group was qualified as a supplier of fire prevention and fighting products to the Fujian Provincial Government in June 2001 and is one of the few enterprises providing fire prevention and fighting equipment which has obtained such qualification in the Fujian Province. The Directors believe that the Group has laid a good foundation for future development in the fire service equipment to governmental bodies.

## 9. Strong shareholders' support

The Group's strategic investors are reputable companies, namely, Cantus, a wholly-owned subsidiary of Aria, a pan-Asian private equity fund managed by CLSA Private Equity Management Limited, YMW, a Japanese-based investment union managed by Yamaichi Hands-on Associates Inc. and Morita, a company engaged in the manufacturing and distribution of fire engines and fire prevention vehicles, whose shares are listed on the Osaka Stock Exchange Limited and Tokyo Stock Exchange Limited. The Directors believe its alliance with Cantus and YMW may provide the Group with extensive business connections via Cantus and YMW's portfolio of investments, whereas its alliance with Morita may aid the Group in the development of its fire engine distribution and other related equipment business. Moreover, the Group may obtain the latest technological know-how from Morita in order to enhance the quality of its services and products. For details, please refer to the section headed "Strategic Investors" on pages 79 to 81 of this prospectus.

## BUSINESS OBJECTIVES

As the importance of fire prevention and fighting has been undermined in general in the PRC, the State has promulgated laws and regulations to rectify people's misconception. The mission of the Group is to become a leader in the fire prevention and fighting industry in the PRC. The Directors believe that the Group's mission can be achieved essentially by the application of the latest technology, enhancement of quality and expansion of the sales network. The Directors are also convinced that a more predictable growth of the Group will be derived from the expansion of its existing businesses and the exploration of new products in the fire safety industry.

The Directors believe that the market for fire prevention and fighting systems in the PRC will continue to grow during the Forward Looking Period.

# SUMMARY

In order to capture the opportunities and achieve its overall business objective, the Group proposes to focus on the following strategies:

- Development of new products with application of advanced technology;
- Enhancement of a strong research and development team;
- Establishment of new production bases and the purchase of new equipment and facilities;
- Expansion of sales and distribution network;
- Marketing, promotion and brand building; and
- Business collaborations and acquisitions.

## REASONS FOR THE PLACING AND USE OF PROCEEDS

The Directors believe that the net proceeds from the issue of New Shares under the Placing will strengthen the Group's capital base and improve its gearing position. The net proceeds will also assist the Group in research and development, corporate and business development, service enhancement, marketing and brand building.

The net proceeds of the issue of New Shares under the Placing, after deduction of underwriting fees and estimated expenses payable by the Company in relation to the Placing, are estimated to be approximately HK\$137.6 million. The Directors currently intend to use the net proceeds from the issue of New Shares under the Placing as follows:

- approximately HK\$20.0 million for the development of new products, obtain production permit as well as launching of new products in the market;
- approximately HK\$10.0 million for the establishment of a research and development centre replacing the existing research and development department and equipped with more advanced facilities. The research and development team will be enlarged and will undertake more research projects on the development of fire prevention and fighting technology;
- approximately HK\$50.0 million for the establishment of new production bases, HK\$20.0 million and HK\$30.0 million will be used to establish a new production base in Western part of China and Fujian respectively;
- approximately HK\$20.0 million for the enhancement and development of the Group's sales and distribution network throughout the PRC amongst which about HK\$10.0 million will be used for the establishment of 10 additional branches, about HK\$5.0 million will be used for the setting up of 5 new demonstration service centres and about HK\$5.0 million will be used for the improvement of the existing 16 branch offices;
- approximately HK\$10.0 million for marketing, promotion and brand building activities to support bidding for installation projects in provinces other than Fujian;

## SUMMARY

- approximately HK\$20.0 million for business collaboration and acquisition of other related businesses and strategic investments amongst which about HK\$10.0 million is earmarked for the acquisition of enterprises in the sector of fire service equipment and fire retardant materials and about HK\$10.0 million is earmarked for the acquisition of enterprises engaged in the manufacturing of sensors and fire alarm system complimentary to the Group; and
- the remaining balance of HK\$7.6 million is expected to be used as general working capital of the Group amongst which about HK\$3.0 million is earmarked for the additional working capital required to manufacture new products, about HK\$2.6 million is earmarked for the additional working capital for the sales of fire service equipment, fire retardant materials and the business of fire service installation projects and about HK\$2.0 million is earmarked for maintaining the day-to-day operation of the Group.

If the Over-allotment Option is exercised in full, the Company will receive additional net proceeds of approximately HK\$29.0 million which the Directors intend to allocate as follows:

- an additional sum of approximately HK\$7.0 million will be allocated for the continuing marketing, promotion and brand building activities which will enable the Group to intensify its marketing programmes;
- an additional sum of approximately HK\$20.0 million will be used for the business collaboration and acquisition of other related businesses and strategic investments amongst which about HK\$10.0 million is earmarked for the acquisition of enterprises in the sector of fire service equipment and fire retardant materials and about HK\$10 million is earmarked for the acquisition of enterprises engaged in the manufacturing of sensors and fire alarm system complimentary to the Group. The Directors consider that the additional funds will enhance the Group's position in the acquisition of such potential enterprises in the industry; and
- an additional sum of HK\$2.0 million will be used as general working capital to maintain the day-to-day operation of the Group.

The Directors consider that if the Over-allotment Option is not exercised, there will not be any material adverse impact on the ability or resources of the Group in relation to the implementation of its business plan as stated under the section headed "Statement of Business Objectives" in this prospectus.

To the extent that the net proceeds of the issue of New Shares under the Placing are not immediately applied for the above purposes, it is the present intention of the Directors that such net proceeds will be placed on short-term, interest-bearing deposits with licensed banks or other financial institutions in Hong Kong.

In the event that there is any material modification to the use of proceeds as stated above, the Company will issue an announcement.

# SUMMARY

## TRADING RECORD

The table below sets out a summary of the combined audited results of the Group for each of the two years ended 31st December, 2001 and the seven months ended 31st July, 2002. The summary is prepared on the basis set out in section A of the accountants' report in Appendix I to this prospectus and should be read in conjunction herewith.

	<i>Note</i>	Year ended 31st December,		Seven months ended 31st July,
		2000 RMB'000	2001 RMB'000	2002 RMB'000
Turnover	<i>1</i>	84,007	193,988	147,553
Cost of sales	<i>1</i>	<u>(32,979)</u>	<u>(76,716)</u>	<u>(54,465)</u>
Gross Profit	<i>1</i>	51,028	117,272	93,088
Other revenue		64	31	526
Distribution costs		(240)	(162)	(917)
Administrative expenses		<u>(6,002)</u>	<u>(10,386)</u>	<u>(8,936)</u>
Profit from operations		44,850	106,755	83,761
Finance costs		<u>(207)</u>	<u>(243)</u>	<u>(241)</u>
Profit before taxation		44,643	106,512	83,520
Taxation		<u>(184)</u>	<u>(7,728)</u>	<u>(8,833)</u>
Profit before minority interests		44,459	98,784	74,687
Minority interests		<u>(3,000)</u>	<u>(4,941)</u>	<u>(179)</u>
Net profit for the year/period		<u><u>41,459</u></u>	<u><u>93,843</u></u>	<u><u>74,508</u></u>
Dividends	<i>2</i>	<u><u>(21,745)</u></u>	<u><u>(88,216)</u></u>	<u><u>–</u></u>
Earnings per share, basic ( <i>cents</i> )	<i>3</i>	<u><u>3.00</u></u>	<u><u>6.79</u></u>	<u><u>4.83</u></u>

# SUMMARY

Notes:

1. Turnover represents Product Sales, Installation Services and Maintenance Services of the Group. The details of such turnovers and the gross profits are as follows:

	Year ended 31st December,		Seven months ended 31st July,
	2000 RMB'000	2001 RMB'000	2002 RMB'000
<b>Turnover</b>			
Product Sales	70,875	143,092	89,518
Cost of Good sold	(26,461)	(50,154)	(32,224)
Gross Profit	44,414	92,938	57,294
Installation Services	13,132	48,400	50,970
Cost of Installation Services	(6,518)	(26,209)	(21,134)
Gross Profit	6,614	22,191	29,836
Maintenance Services	–	2,496	7,065
Cost of Maintenance Services	–	(353)	(1,107)
Gross profit	–	2,143	5,958
<b>Total turnover</b>	84,007	193,988	147,553
Cost of sales	(32,979)	(76,716)	(54,465)
Total Gross Profit	51,028	117,272	93,088

2. For the two years ended 31st December, 2001 and the seven months ended 31st July, 2002, the Group paid dividends of approximately RMB21.7 million, RMB55.2 million and nil respectively to its then equity holders. In addition, a dividend of RMB33.0 million was declared in November 2001 and subsequently assigned by Mr. Jiang Xiong to Wang Sing pursuant to the Reorganisation.
3. The calculation of the basic earnings per Share for each of the two years ended 31st December, 2001 is based on the combined profits for each of the respective years and on the 1,381,600,000 Shares attributable to Mr. Jiang Xiong as if those Shares had been in issue throughout the two years ended 31st December, 2001. The calculation of the basic earnings per Share for the seven months ended 31st July, 2002 is based on the combined profits for the seven months ended 31st July, 2002 and on the weighted average number of 1,541,279,245 Shares attributable to Mr. Jiang Xiong, Cantus, YMW and Morita as if those Shares had been in issue throughout the seven months ended 31st July, 2002.

There were no potential dilutive ordinary shares in issue during the two years ended 31st December, 2001 and the seven months ended 31st July, 2002.

## PLACING STATISTICS

Issue Price	HK\$0.4
Market capitalisation ( <i>Note 1</i> )	HK\$800 million
Adjusted net tangible asset value per Share ( <i>Note 2</i> )	RMB15.09 cents

Notes:

1. The calculation of market capitalisation of the Shares is based on the Issue Price and 2,000,000,000 Shares in issue immediately after the completion of the Placing but takes no account of any Shares which may be issued pursuant to the exercise of the Over-allotment Option or any options which may be granted under the Share Option Scheme or which may be allotted and issued or purchased by the Company pursuant to the general mandate for the allotment and issue or purchase of Shares described in the sub-paragraph headed "Written resolutions of the sole shareholder of the Company passed on 12th July, 2002 and 20th September, 2002" under the section headed "Further information about the Company" in Appendix IV to this prospectus.



# SUMMARY

2. The adjusted net tangible asset value per Share has been arrived at after making the adjustments referred to in the paragraph headed “Adjusted net tangible assets“ under the section headed “Financial information” of this prospectus and on the basis of an aggregate of 2,000,000,000 Shares in issue and to be issued as mentioned herein but takes no account of any Shares which may be issued pursuant to the exercise of the Over-allotment Option or any options which may be granted under the Share Option Scheme or which may be allotted and issued or purchased by the Company pursuant to the general mandate for the allotment and issue or purchase of Shares described in the paragraph headed “Written resolutions of the sole shareholder of the Company passed on 12th July, 2002 and 20th September, 2002” under the section headed “Further information about the Company” in Appendix IV to this prospectus.

## STRUCTURE AND CONDITIONS OF THE PLACING

The Company is offering 400,000,000 New Shares for subscription pursuant to the Placing and the Vendor is offering 100,000,000 Sale Shares for purchase pursuant to the Placing, representing approximately 20 per cent. and 5 per cent. respectively of the issued share capital of the Company upon completion of the Placing. The Placing is fully underwritten by the Underwriters, subject to the terms and conditions of the Underwriting Agreement. Further details are set out in the section headed “Structure and conditions of the Placing” in this prospectus.

## SHARE OPTION SCHEME

On 20th September, 2002, the Company conditionally adopted the Share Option Scheme pursuant to which options to subscribe for Shares may be granted to full time employees and directors of any member of the Group during the term of the Share Option Scheme. A summary of the rules of Share Option Scheme is set out in the paragraph headed “Share Option Scheme” under the section headed “Further information about directors, senior management and staff” in Appendix IV to this prospectus.

## SHAREHOLDING STRUCTURE

The shareholding structure of the Company immediately after the Placing is summarised below:

Shareholder	Date of becoming shareholder	Number of Shares held immediately after the Placing (if Over-allotment Option not exercised)	Percentage of shareholding immediately after the Placing (if Over-allotment Option not exercised) %	Percentage of shareholding immediately after the Placing (if Over-allotment Option exercised in full) %	Approximate total cost of investment	Approximate cost of investment per Share
<i>Initial Management Shareholder</i>						
Mr. Jiang Xiong	20th December, 1993	1,281,600,000	64.08%	61.76%	RMB10,185,000	RMB0.007 <i>Note 1</i>
<i>Significant Shareholder</i>						
Cantus ( <i>Note 2</i> )	1st March, 2002	160,000,000	8%	7.71%	HK\$40,000,000	HK\$0.25 <i>Note 2</i>
<i>Other Shareholders</i>						
YMW ( <i>Note 3</i> )	1st March, 2002	35,040,000	1.75%	1.69%	HK\$8,745,900	HK\$0.25 <i>Note 3</i>
Morita ( <i>Note 4</i> )	1st March, 2002	23,360,000	1.17%	1.13%	HK\$5,830,600	HK\$0.25 <i>Note 4</i>
Public Shareholders		500,000,000	25%	27.71%		
Total		<u>2,000,000,000</u>	<u>100.00%</u>	<u>100.00%</u>		

# SUMMARY

*Note:*

1. As part of the Reorganisation, Mr. Jiang Xiong sold his 8,635 shares in Wang Sing to the Company in exchange for the allotment and issue of 1,381,599,990 Shares, credited as fully paid, to him. Further details of the Reorganisation are set out in the paragraph headed “Corporate reorganisation” under the section headed “Further information about the Company” in Appendix IV to this prospectus. Under the Placing, Mr. Jiang Xiong will dispose of 100,000,000 Shares at HK\$0.50 each. Immediately following the completion of the Placing, the number of Shares held by Mr. Jiang Xiong will be 1,281,600,000.
2. Cantus, an investment company, is a wholly-owned subsidiary of Aria, a pan-Asian private equity fund managed by CLSA Private Equity Management Limited. CLSA Private Equity Management Limited is a specialist private equity investment management firm focused on Asian equity investment and belongs to the CLSA Emerging Markets Group. Aria is an exempted limited partnership organised under the laws of the Cayman Islands on 18th April, 2000. CLSA Private Equity Management Limited is the general partner and manages the partnership on a discretionary basis. The partnership’s objective is to achieve substantial long-term capital appreciation through the purchase, investment management, and disposition of a portfolio of direct investments in equity and equity related securities of companies operating directly or indirectly in the target markets. Currently, Aria has six limited partners, one special limited partner and one general partner. The partnership’s investment commitments are approximately US\$75 million and its portfolio companies include various sectors namely, media, consumer products and retail industries.

On 1st March, 2002, Cantus was issued 1,000 shares in the capital of Wang Sing, a wholly-owned subsidiary of the Company, pursuant to a share subscription agreement dated 27th February, 2002 entered into between Cantus, Mr. Jiang Xiong and Wang Sing, at a consideration of approximately HK\$40,000,000, which shares were subsequently exchanged for 160,000,000 Shares after the Reorganisation. The 160,000,000 Shares are indirectly held by Aria via its direct interest in Cantus.

Save as disclosed in this note and the paragraph headed “Strategic Investors” under the section headed “General overview of the Group” in this prospectus, none of the directors or shareholders of Cantus are connected with the Directors, Initial Management Shareholder, Substantial Shareholder, the chief executives and/or the respective associates of the Company.

Please also refer to the section headed “Substantial shareholder, initial management shareholder, significant shareholder and other shareholders” in this prospectus.

3. YMW is a Japanese-based investment union which is approved by Japanese Civil Law Article 667. The activity is mainly to invest in the venture companies which are not listed on any stock exchanges. The portfolio size of YMW is approximately ¥163 million and has 25 fundholders. Yamaichi Hands-on Associates Inc., being one of the fundholders, is also the general partner of YMW and manages YMW for the fundholders on a discretionary basis.

Yamaichi Hands-on Associates Inc. was established in Japan in December 2000 with a capital based of ¥50 million as at Latest Practical Date. It manages 2 funds, namely Yamaichi Hands-on No. 1 Fund and YMW, and the total size of these funds are approximately ¥210 million as at the Latest Practicable Date.

On 1st March, 2002, YMW was issued 219 shares in the capital of Wang Sing, a wholly-owned subsidiary of the Company, pursuant to a subscription agreement dated 27th February, 2002 entered into between YMW, Mr. Jiang Xiong and Wang Sing, at a consideration of approximately HK\$8,745,900, which shares were subsequently exchanged for 35,040,000 Shares after the Reorganisation.

Each of YMW, Cantus and Morita entered into a separate subscription agreement with Wang Sing and Mr. Jiang Xiong on 27th February, 2002 on substantially the same terms to subscribe for shares of Wang Sing, and, following commercial negotiations, YMW agreed to the restrictions on disposal of its Shares as if it were a Significant Shareholder.

Save as disclosed in this note and the paragraph headed “Strategic Investors” under the section headed “General overview of the Group” in this prospectus, none of the directors or fundholders of YMW are connected with the Directors, Initial Management Shareholder, Substantial Shareholder, the chief executives and/or the respective associates of the Company.

Please also refer to the section headed “Substantial shareholder, initial management shareholder, significant shareholder and other shareholders” in this prospectus.

# SUMMARY

4. Morita is a company engaged in the manufacturing and distribution of fire engines and fire prevention vehicles which is listed on the Osaka Stock Exchange Limited and Tokyo Stock Exchange Limited. The market capitalisation of Morita as at the Latest Practicable Date is approximately ¥18,512.35 million, equivalent to approximately HK\$1,203.30 million.

On 1st March, 2002, Morita was issued 146 shares in the capital of Wang Sing, a wholly-owned subsidiary of the Company, pursuant to a subscription agreement dated 27th February, 2002 entered into between Morita, Mr. Jiang Xiong and Wang Sing, at a consideration of approximately HK\$5,830,600 which shares were subsequently exchanged for 23,360,000 Shares after the Reorganisation.

Each of Morita, Cantus and YMW entered into a separate subscription agreement with Wang Sing and Mr. Jiang Xiong on 27th February, 2002 on substantially the same terms to subscribe for shares of Wang Sing, and, following commercial negotiations, Morita agreed to the restrictions on disposal of its Shares as if it were a Significant Shareholder.

Save as disclosed in this note and the paragraph headed “Strategic Investors” under the section headed “General overview of the Group” in this prospectus, none of the directors or substantial shareholders of Morita are connected with the Directors, Initial Management Shareholder, Substantial Shareholder, the chief executives and/or the respective associates of the Company.

Please also refer to the section headed “Substantial shareholder, initial management shareholder, significant shareholder and other shareholders” in this prospectus.

## RESTRICTION ON DISPOSAL OF SHARES

Name of shareholders	Number of Shares held immediately after the Placing (before Over-allotment Option)	Percentage of shareholding immediately after the Placing (before Over-allotment Option) %	Number of Shares subject to lock-up	Percentage of shareholding subject to lock-up %	Lock-up Period	Notes
<i>Initial Management Shareholder</i>						
Mr. Jiang Xiong	1,281,600,000	64.08%	1,281,600,000	64.08%	12 months	1
<i>Significant Shareholder</i>						
Cantus	160,000,000	8.00%	160,000,000	8.00%	6 months	2, 3
<i>Other Shareholders</i>						
YMW	35,040,000	1.75%	35,040,000	1.75%	6 months	4
Morita	23,360,000	1.17%	23,360,000	1.17%	6 months	5
Total	<u>1,500,000,000</u>	<u>75.00%</u>	<u>1,500,000,000</u>	<u>75.00%</u>		

Notes:

1. Mr. Jiang Xiong, being the Initial Management Shareholder, has undertaken to the Company, CPY, CPY International (for and on behalf of the Underwriters) and the Stock Exchange that he will:
  - (i) place in escrow, with an escrow agent and on such terms as are acceptable to the Stock Exchange, his Relevant Securities in the Company during the Lock-up Period; and
  - (ii) save for the exercise of the Over-allotment Option and the circumstances provided by Rule 13.18 of the GEM Listing Rules, during the Lock-up Period, not dispose of (or enter into any agreement to dispose of) nor permit the registered holder to dispose of (or enter into any agreement to dispose of) any of his direct or indirect interests in the Relevant Securities of the Company.

# SUMMARY

2. Cantus, being a Significant Shareholder, has undertaken with the Company, CPY, CPY International (for and on behalf of the Underwriters) and the Stock Exchange that it will:
  - (i) place in escrow, with an escrow agent and on such terms as are acceptable to the Stock Exchange, its Relevant Securities in the Company for a period of 6 months from the Listing Date; and
  - (ii) save for the circumstances provided by Rule 13.18 of the GEM Listing Rules, not dispose of (or enter into any agreement to dispose of) nor permit the registered holder to dispose of (or enter into any agreement to dispose of) any of its direct or indirect interest in the Relevant Securities of the Company for a period of 6 months from the Listing Date.
3. The 160,000,000 Shares are indirectly held by Aria via its direct interests in its subsidiary, Cantus. Aria has given an undertaking to the Company, CPY, CPY International (for and on behalf of the Underwriters) and the Stock Exchange that it will not, during the 6 months from the Listing Date, dispose of (or enter into any agreement to dispose of) any of its direct or indirect interest in the capital of Cantus.
4. YMW, being a strategic shareholder of the Company, has undertaken with the Company, CPY, CPY International (for and on behalf of the Underwriters) and the Stock Exchange that it will:
  - (i) place in escrow, with an escrow agent and on such terms as are acceptable to the Stock Exchange, its Relevant Securities in the Company for a period of 6 months from the Listing Date; and
  - (ii) save for the circumstances provided by Rule 13.18 of the GEM Listing Rules, not dispose of (or enter into any agreement to dispose of) nor permit the registered holder to dispose of (or enter into any agreement to dispose of) any of its direct or indirect interest in the Relevant Securities of the Company for a period of 6 months from the Listing Date.

Yamaichi Hands-on Associates Inc., the fund manager of YMW, has given an undertaking to the Company, CPY, CPY International (for and on behalf of the Underwriters) and the Stock Exchange, details of which are set out in the paragraph headed “Further undertakings” in the section headed “Substantial shareholder, initial management shareholder, significant shareholder and other shareholders” in this prospectus.
5. Morita, being a strategic shareholder of the Company, has undertaken with the Company, CPY, CPY International (for and on behalf of the Underwriters) and the Stock Exchange that it will:
  - (i) place in escrow, with an escrow agent and on such terms as are acceptable to the Stock Exchange, its Relevant Securities in the Company for a period of 6 months from the Listing Date; and
  - (ii) save for the circumstances provided by Rule 13.18 of the GEM Listing Rules, not dispose of (or enter into any agreement to dispose of) nor permit the registered holder to dispose of (or enter into any agreement to dispose of) any of its direct or indirect interest in the Relevant Securities of the Company for a period of 6 months from the Listing Date.

## RISK FACTORS

The Directors consider that the operations and results of the Group are subject to certain risks which can be categorised into (i) risks relating to the Group; (ii) risks relating to the industry; (iii) risks relating to the PRC; and (iv) issues relating to statements made in this prospectus:

### **Risks relating to the Group** (pages 21 to 25)

- Sustainability of profit
- Lack of experience with rapid expansion
- Failure to renew certificates and licences
- Expiry of preferential tax treatment or non-exemption of income tax if revenue generated from Product Sales is less than 50% of total revenue

# SUMMARY

- The Group's operation may be affected due to the relocation of existing production facilities
- Lack of land use right and/or building ownership certificates of the Group's owned properties in the PRC
- Risks associated with possible acquisitions
- Reliance on the PRC market
- Uncertainty on future expansion
- Potential product liability
- Infringement of intellectual property rights
- Reliance on key management
- Dividend policy

## **Risks relating to the industry** (page 25)

- Competition
- Heavy reliance on the construction market in the PRC

## **Risks relating to the PRC** (page 26 to 28)

- Political and economic considerations
- Changes in laws, regulations and policies
- Changes in foreign exchange regulations
- Currency and exchange fluctuations

## **Issues relating to statements made in this prospectus** (page 28)

- Unofficial statistics

## DEFINITIONS

*In this prospectus, unless the context otherwise requires, the following words and expressions have the following meanings:*

“Aria”	Aria Investment Partners, L.P., an exempted limited partnership organised under the laws of the Cayman Islands on 18th April, 2000, the objective of which is to achieve substantial long-term capital appreciation through the purchase, investment management, and disposition of a portfolio of direct investments in equity and equity related securities of companies operating directly or indirectly in the target markets
“Articles”	articles of association of the Company
“associate(s)”	has the meaning ascribed to it in the GEM Listing Rules
“Banking Ordinance”	Banking Ordinance (Chapter 155 of the Laws of Hong Kong)
“BVI”	British Virgin Islands
“Cantus”	Cantus Limited, a company incorporated in the Cayman Islands and a wholly-owned subsidiary of Aria
“CCASS”	Central Clearing and Settlement System established and operated by HKSCC
“CCCFP”	China Certification Committee for Fire Prevention Products Quality (中國消防產品質量認證委員會)
“CCLQ”	China Certification Centre of Light Industry Quality (中國輕工質量認證中心)
“CFPA”	China Fire Protection Association (中國消防協會)
“CLSA Emerging Markets Group”	A sub-group of Credit Lyonnais Bank and comprising leading brokerages and investment firms in the emerging markets of Asia. “CLSA Emerging Markets Group” is used by CLSA Limited, a company incorporated in Hong Kong for marketing CLSA group of companies.
“Companies Law”	Companies Law Cap. 22 (Law 3 of 1961, as consolidated and revised) of the Cayman Islands
“Companies Ordinance”	Companies Ordinance (Chapter 32 of the Laws of Hong Kong)
“Company”	Wanyou Fire Safety Technology Holdings Limited, an exempted company incorporated in the Cayman Islands on 3rd January, 2002 with limited liability
“Connected Person(s)”	has the meaning ascribed to it in Chapter 20 of the GEM Listing Rules

## DEFINITIONS

“CPY” or “Sponsor”	Core Pacific-Yamaichi Capital Limited, the sponsor of the Placing, an investment adviser and dealer registered under the Securities Ordinance
“CPY International”	Core Pacific-Yamaichi International (H.K.) Limited, one of the joint lead managers for the Placing and an investment adviser and dealer registered under the Securities Ordinance
“Director(s)”	director(s) of the Company
“Forward Looking Period”	period commencing from the Latest Practicable Date and ending on 31st December, 2004
“Fujian Wanan”	Fujian Wanan Technology Development Company Ltd. (福建省萬安科技發展有限公司), a limited liability company established in the PRC on 25th September, 1997 and its existing shareholders are independent of the Group’s directors, chief executives or their associates
“Fujian Wanyou”	Fujian Wanyou Fire Fighting Science and Technology Co., Ltd. (福建萬友消防科技有限公司), and its predecessors as the context requires. Fujian Wanyou Fire Fighting Science and Technology Co., Ltd. was established in the PRC on 20th December, 1993 as a private-owned enterprise and changed its status to a wholly foreign owned enterprise on 17th December, 2001 and an indirect wholly owned subsidiary of the Company
“GEM”	Growth Enterprise Market of the Stock Exchange
“GEM Listing Rules”	Rules Governing the Listing of Securities on the GEM
“Group”	Company and its subsidiaries or, where the context so requires, in respect of the period before the Company became the holding company of its present subsidiaries, the present subsidiaries of the Company
“HKSCC”	Hong Kong Securities Clearing Company Limited
“Hong Kong” or “HK”	the Hong Kong Special Administrative Region of the PRC
“ICEA”	ICEA Capital Limited, one of the joint lead managers and a registered dealer under the Securities Ordinance (Chapter 333 of the Laws of Hong Kong)
“Initial Management Shareholder”	has the meaning ascribed to it under rule 13.15(2) of the GEM Listing Rules and in this context, means Mr. Jiang Xiong
“Installation Services”	installation services of fire prevention and fighting systems in construction projects and buildings

## DEFINITIONS

“Issue Price”	price of HK\$0.40 per Share, exclusive of brokerage and the Stock Exchange trading fee, the Securities and Futures Commission transaction levy, payable on application under the Placing
“Latest Practicable Date”	19th September, 2002, being the latest practicable date prior to the printing of this prospectus for ascertaining certain information contained herein
“Listing Date”	the date on which dealings in the Shares commence on the GEM
“Lock-up Period”	a period of 12 months from the Listing Date
“Main Board”	the stock market operated by the Stock Exchange prior to the establishment of the GEM (excluding the option market) and which stock market continues to be operated by the Stock Exchange in parallel with the GEM
“Maintenance Services”	inspection and maintenance services of fire prevention and fighting systems in construction projects and premises
“Morita”	Morita Corporation, a corporation established in Japan and listed on the Tokyo Stock Exchange Limited and the Osaka Stock Exchange Limited. It is principally engaged in the manufacturing and distribution of fire engines and fire prevention vehicles
“New Shares”	400,000,000 new Shares being offered for subscription under the Placing, together with, where the context requires, the Over-allotment Option
“Over-allotment Option”	the option to be granted by the Company to the Underwriters exercisable by ICEA on behalf of the Underwriters pursuant to the Underwriting Agreement under which the Company may be required to allot and issue at the Issue Price the Over-allotment Shares, representing approximately 15 per cent. of the number of Shares initially being offered under the Placing, solely to cover over-allocations under the Placing
“Over-allotment Shares”	up to 75,000,000 additional new Shares to be allotted and issued by the Company pursuant to the exercise of the Over-allotment Option
“Placing”	conditional placing by the Underwriters of the Placing Shares at the Issue Price as described in the section headed “Structure and conditions of the Placing” in this prospectus
“Placing Shares”	the New Shares being offered by the Company for subscription and the Sale Shares initially being offered by the Vendor for purchase at the Issue Price under the Placing respectively, together with, where the context requires, the Over-allotment Shares



## DEFINITIONS

“Product Sales”	sales of fire prevention and fighting products, including, but not limited to, products for fire alarm systems and emergency lighting systems, produced by the Group
“PRC” or “China”	People’s Republic of China which, for the purposes of this prospectus and for geographical reference only (unless otherwise stated), does not include Hong Kong, the Macau Special Administrative Region and Taiwan
“Relevant Securities”	has the meaning ascribed to it in Rule 13.15 of the GEM Listing Rules
“Reorganisation”	reorganisation of the companies now comprising the Group in preparation for the listing of the Shares on the GEM, details of which are described in the paragraph headed “Corporate reorganisation” in Appendix IV to this prospectus
“Sale Shares”	100,000,000 existing Shares offered for sale by the Vendor under the Placing
“SDI Ordinance”	Securities (Disclosure of Interests) Ordinance (Chapter 396 of the Laws of Hong Kong)
“Securities Ordinance”	Securities Ordinance (Chapter 333 of the Laws of Hong Kong)
“Share(s)”	share(s) of HK\$0.01 each in the share capital of the Company
“Share Option Scheme”	share option scheme conditionally adopted by the Company on 20th September, 2002, the principal terms of which are summarised in the paragraph headed “Share Option Scheme” under the section headed “Further information about directors, senior management and staff” in Appendix IV to this prospectus
“Significant Shareholder”	has the meaning ascribed to it under the GEM Listing Rules
“Singapore”	the Republic of Singapore
“SAIC”	State Administration of Industry and Commerce of the PRC (中國國家工商行政管理局)
“SIPO”	State Intellectual Property Office of the PRC (中華人民共和國國家知識產權局)
“State”	the PRC government
“Stock Exchange”	The Stock Exchange of Hong Kong Limited
“Substantial Shareholder”	has the meaning ascribed to it under the GEM Listing Rules
“Track Record Period”	the two financial years ended 31st December, 2001 and the seven months ended 31st July, 2002

## DEFINITIONS

“Underwriters”	Core Pacific - Yamaichi International (H.K.) Limited, ICEA Capital Limited, CLSA Limited, Karl-Thomson Securities Company Limited, Nomura International (Hong Kong) Limited, Phoenix Capital Securities Limited, Sun Hung Kai International Limited and The Bank of East Asia, Limited
“Underwriting Agreement”	underwriting and placing agreement dated 20th September, 2002 entered into between, among others, the Company, the executive Directors, CPY and the Underwriters, relating to the Placing, particulars of which are summarised in the section headed “Underwriting” in this prospectus
“US”, “USA” or “United States”	United States of America
“US Wanyou”	Wang You Fire Technology Limited, a company incorporated in Delaware, United States on 5th March, 2002 and is an indirect wholly owned subsidiary of the Company
“Wang Sing”	Wang Sing Technology Limited, a company incorporated in the British Virgin Islands on 12th October, 2000 and is a direct wholly owned subsidiary of the Company
“Vendor”	Mr. Jiang Xiong
“Wanyou Engineering”	Fujian Wanyou Fire Engineering Company Limited (福建省萬友消防工程有限公司), a limited liability company established in the PRC on 23rd December, 1996 and is a subsidiary 99% owned by Fujian Wanyou
“WTO”	World Trade Organisation
“YMW”	Yamaichi MW Fund, a Japanese-based investment union which is approved by Japanese Civil Law Article 667 and its activity is mainly to invest in the venture companies which are not yet listed on any stock exchange.
“HK\$” and “HK cents”	Hong Kong dollars and cents respectively, the lawful currency of Hong Kong
“JPY” or “¥”	Japanese yen, the lawful currency of Japan
“RMB”	Renminbi, the lawful currency of the PRC
“US\$” or “US dollars”	United States dollars, the lawful currency of the United States
“sq. ft.”	square feet
“sq. m.”	square metres
“%”	per cent.

For the purpose of this prospectus, unless otherwise indicated, exchange rates of HK\$7.788 = US\$1.00, HK\$0.92 = RMB1.00 and HK\$0.058 = JPY1.00 have been used for currency translations, where applicable, for purposes of illustration only and do not constitute a representation that any amount has been or may be exchanged, at these or any other rates.

## GLOSSARY OF TECHNICAL TERMS

“CE”	A conformity mark, meaning conformity with the essential requirements by the application of high level technical specifications for the protection of users, consumers and other parties involved. It symbolises the conformity of the product with the applicable European community requirements imposed on the manufacturer
“Class 1 license”	license issued to enterprises in Fujian, the PRC allowing them to undertake all types of fire service installation projects for different kinds of buildings
“CPU”	Central Processing Unit
“emergency lighting systems”	appliances or devices installed in premises to provide illumination when there is an accident or a fire hazard
“fire alarm systems”	appliances or devices installed in premises to give warning of or announcing the outbreak of fire
“fire extinguishing systems” or “fire suppression systems”	appliances or devices installed in premises to carry water or chemicals for extinguishing and dousing fire
“fire-fighting gear control system”	a control device installed in premises to connect the emergency lighting system, fire alarm systems and fire extinguishing systems
“fire prevention and fighting systems”	fire alarm systems, emergency lighting systems and fire extinguishing systems installed in premises for the purposes of giving warning of, preventing or extinguishing fire
“fire prevention and fighting systems installation”	the design, installation and management of fire prevention and fighting systems in different types of premises. The installations may be fixed or portable and are operated either automatically or manually
“fire services”	the services provided by fire services departments
“ISO9002”	an international standard quality management system for quality assurance in production, inspection, installation and servicing
“smoke prevention and exhaustion system”	appliances or devices installed in premises to prevent smoke spreading or evacuate smoke resulting from fire
“UL”	Underwriters Laboratories Inc., an independent, not-for-profit product safety testing and certification organisation in US

# RISK FACTORS

*Investors should consider carefully all of the information set out in this prospectus and, in particular, should evaluate the following risks in connection with an investment in the Group. Investment in the PRC carries a high degree of risk. In addition to normal investment risks, the Group's business in the PRC will be subject to certain risks that are unique to that country.*

## **RISKS RELATING TO THE GROUP**

### **Sustainability of profit**

The Group achieved a significant growth in net profit attributable to shareholders from approximately RMB41.5 million for the year ended 31st December, 2000, to approximately RMB93.8 million for the year ended 31st December, 2001 and to approximately RMB74.5 million for the seven months ended 31st July, 2002 due to the success in marketing activities and the gradual setting up of a comprehensive distribution network. Following the further opening of China and the consequential improvement of domestic products' quality, there will be strong competition from both overseas and domestic manufacturers. The Group may not be able to maintain or expand its market share in the fire prevention and fighting equipment and fire prevention and fighting system installation markets as planned. As such, there can be no assurance that the Group can continue to achieve a high rate of growth in its profit in the future.

### **Lack of experience with rapid expansion**

It is important that the management team can manage growth of the Group effectively. To manage the growth, the management team must continue to improve the operational and financial systems, procedures and controls of the Group, and expand the number of its employees as well as providing training to them. If the Group's systems, procedures and controls are inadequate to support its operation, its expansion would be halted and any inability to manage growth effectively could have a material effect on the Group's rapid future development.

### **Failure to renew certificates and licences**

In order to carry out fire prevention and fighting equipment and fire prevention and fighting systems installation businesses in the PRC, enterprises are required to obtain certificates and licences from the fire services departments of their respective provincial levels. Fire Prevention and Fighting Product Production Licence (消防產品生產許可證) and Fire Prevention and Fighting Systems Installation Licence (自動消防系統工程施工許可證) are subject to annual examination. It should be noted that the standards of compliance required may change from time to time, giving rise to compliance problems. In the event that any of the certificates or permits is not renewed, the Group's operation which relies on such certificates or permits will have to cease and the business and profitability of the Group could be materially affected.

### **Expiry of preferential tax treatment or non-exemption of income tax if revenue generated from Product Sales is less than 50% of total revenue**

Fujian Wanyou, being the production enterprise of the Group, is classified as a High New Technology Enterprise (高新技術企業) by the tax bureau of the PRC and is accordingly exempted from PRC income tax for the two years ended 31st December, 2001. As a wholly foreign owned enterprise, Fujian Wanyou is entitled to two years' exemption from income tax followed by three years of 50% tax reduction commencing from the first-profit-making year. Should such preferential tax treatment expire or the Group fail to obtain other similar tax treatment, the future tax burden will increase significantly which in turn could have substantial negative impact on the profitability

## RISK FACTORS

of the Group. In addition, if the revenue generated from Product Sales of Fujian Wanyou during a year is less than 50% of its total revenue earned for that year, no exemption or reduction of income tax will be allowed and full income tax has to be paid even though it falls within the exemption or reduction of tax preferential treatment.

### **The Group's operation may be affected due to the relocation of existing production facilities**

The current production facility of the Group is located in a premise with a lease term of 15 years from 1st July, 2001 to 1st July, 2016. The name of the landlord is Fujian Xian Feng Group Company Ltd. (福建先鋒集團公司) (“Xian Feng”) which is engaged in the sales of construction materials in the PRC. The landlord has obtained the relevant land use right building ownership certificate. Although the Group has the intention to acquire a parcel of land for the construction of a new production base in Fujian (the details of the business plan are set out in the “proposed implementation plans” of the section headed “Statement of business objectives”), the Directors intend to maintain the existing production facility in the present location for the manufacturing of its existing products while the new production base will mainly be used for the manufacturing of new products. In addition, Xian Feng has confirmed that it will not unilaterally terminate the lease before the expiry of the lease period. Should the Group be unable to renew the existing lease and relocate the production facility in time, the Group's operation may be adversely affected.

The Directors do not foresee any difficulty to find an appropriate location in Fuzhou for relocation, if required. Since the Group's production operations consist of assembling of parts and testing which are not under any environmental specifications and has no special requirement for industrial properties, the Directors believe that most of the industrial properties in Fuzhou are suitable for the relocation of the Group's production base. In addition, the Directors also consider that the machinery and equipment can be removed without impairments and difficulties if relocation is necessary. The costs of relocation are estimated to be approximately RMB469,000 which includes the transportation cost of machinery and equipment of approximately RMB200,000 and the cost of abandoned equipment and fixture (being the net book value as at 31st December, 2001) of approximately RMB269,000, respectively.

Each of the executive Directors (collectively known as the “Indemnifiers”), has entered into a deed of indemnity with and in favour of the Company (for itself and as trustee for its subsidiaries) to provide, inter alia, indemnities against any claims, costs, expenses, liabilities, losses or proceedings incurred by the Group as a result of, or in connection with, the relocation due to the expiry or termination of the existing tenancy of the Group's production facility. Details of the indemnities are set out in the paragraph headed “Estate duty, tax and other indemnities” in Appendix IV to this prospectus.

### **Lack of land use right and/or building ownership certificates of the Group's owned properties in the PRC**

The Group currently owns two properties in the PRC, one in Fuzhou and the other in Xiamen. The property in Fuzhou is used as the PRC head office of the Group. It comprises two office floors on the 8th and 9th floors and three private car parking spaces on the basement of a commercial building named Gao Jing Trade Centre (高景商業中心), which is located at No. 158 Wu Yi Bei Road, Fuzhou City, Fujian Province, the PRC. The property in Xiamen is one of the branch offices of the Group and is located at Unit B, 17th Floor, Jin Shan Building (金山大廈), No. 862 Xia He Road, Xiamen City, Fujian Province, the PRC.

## RISK FACTORS

The Group does not hold the land use right certificate relating to the property in Fuzhou which is held by and in the name of Fujian Gaojin Real Estate Company Limited (福建高景房地產開發有限公司) (“Gaojin Real Estate”), the property developer for Gao Jing Trade Centre for a term of 50 years from May 1995. Although the Group’s PRC legal advisors confirmed that the Group has the right to apply for the land use right certificate from Fuzhou Land Administration Bureau (福州市土地管理局) and that such application has no legal obstacle, there is a risk that the Group may not be issued the land use right certificate by Fuzhou Land Administration Bureau (福州市土地管理局). The Group’s PRC legal advisors confirm that the Group has paid all land premium and other public utilities fees in respect of the property in Fuzhou and is not liable to pay additional land premium and other governmental fees. The Group’s PRC legal advisors also confirm that the Group does not have to obtain approvals from any relevant government authorities to hold, use, sell, lease or mortgage the property in Fuzhou.

For the property in Xiamen, the Directors confirm that the Group is in the process of applying the Building Ownership Certificate. The Building Ownership Certificate will be issued to the Group by Xiamen Land and Housing Administration Bureau (廈門市土地房屋管理局) which has to survey, check and verify the floor area of every single unit of a building before the Building Ownership Certificate will be issued. Accordingly, it takes time for the Building Ownership Certificate to be issued to the Group and the Directors believe that the Group will obtain such Building Ownership Certificate by early November 2002 and the Group’s PRC legal advisors confirm that the obtaining of such Building Ownership Certificate by the Group has no legal obstacle. However, if the Group fails to obtain such Building Ownership Certificate, then the Group will not be able to lawfully transfer, sell, lease or mortgage the property in Xiamen. In addition, the land use right certificate of the property in Xiamen is held by and in the name of Beiqing (Xiamen) Property Development Company Limited (北慶(廈門)房地產開發有限公司), the property developer of Jin Shan Building, for a term of 50 years from July 1993. The Group’s PRC legal advisors confirm that the Group has paid all land premium and other public utilities fees in respect of the property in Xiamen and is not liable to pay additional land premium and other governmental fees. The Group’s PRC legal advisors also confirm that except for the obtaining of the Building Ownership Certificate, the Group does not have to obtain approvals from any relevant government authorities to hold, use, sell, lease or mortgage the property in Xiamen.

Each of the executive Directors (collectively known as the “Indemnifiers”) has entered into a deed of indemnity with and in favour of the Company (for itself and as trustee for its subsidiaries) to provide, inter alia, indemnities against any claims, costs, expenses, liabilities, losses or proceedings incurred by the Group as a result of, or in connection with, or arising out of any non-compliance and/or breach of the term of any authorisations, permits or approvals that have to be, or required in relation to the properties owned by the Group in the PRC. Details of the indemnities are set out in the paragraph headed “Estate duty, tax and other indemnities” in Appendix IV to this prospectus.

### **Risks associated with possible acquisitions**

The Group may pursue potential acquisitions of businesses, products and technologies that could complement or expand the Group’s business. There can be no assurance that the Group will be able to identify any appropriate acquisition candidates. Even if the Group is able to identify an acquisition candidate, there can be no assurance that the Group will be able to successfully negotiate the terms of any such acquisition, finance such acquisition or integrate such acquired business, products or technologies into the Group’s existing business and products. There is no assurance that a given potential acquisition, would have a positive effect on the Group’s business, financial condition and results of operations. If the Company consummates one or more significant acquisitions the consideration of which consists of Shares, shareholders could suffer dilution of their ownership interests in the Company.

# RISK FACTORS

## **Reliance on the PRC market**

For the two years ended 31st December, 2001 and the seven months ended 31st July, 2002, all of the Group's turnover was derived in the PRC. The Directors anticipated that the PRC will continue to be the Group's largest market in the foreseeable future. Should there be any material adverse change in the political, economic, legal and social conditions in the PRC, the Group's business and profitability may be materially adversely affected.

## **Uncertainty on future expansion**

The Group plans to expand its business in fire services installation and fire prevention and fighting equipment markets in the forthcoming period. Such strategies may involve certain strategic marketing and advertising campaigns, further achievements in research and development and acquisitions of companies. There can be no assurance that such plan will be successful in the future. In addition, the Group's expansion plan may place a significant strain on the Group's management, operation and financial resources. There can be no assurance that the management will be able to manage the future growth of the Group successfully. Should the Group's resources be inadequate to support its future expansion, the Group's business and operations may be adversely affected.

## **Potential product liability**

The Group currently does not maintain any insurance against product liabilities of its products and services provided as it is not a statutory requirement under the current PRC laws and regulations. The Group has not experienced any third party claim in relation to its products and services since establishment. However, there is no assurance that there would not be any such claims against the Group. Given that the Group did not have any product liability insurance during the two years ended 31st December, 2001 and the seven months ended 31st July, 2002, any significant product liability claim could have a material effect on the Group.

Each of the executive Directors has entered into a deed of indemnity with and in favour of the Company (for itself and as trustee for its subsidiaries) to provide, inter alia, indemnities against any claims, costs, expenses, losses and proceedings which might have been incurred or suffered by any member of the Group resulting from or due to a claim for breach of warranty, manufacturing defect, design defect, merchantability, fitness for purpose, negligence or product liability or any other claim attributable to the products sold or to be sold and/or for services provided or to be provided by the Group from time to time before Listing Date. Details of the indemnities are set out in the paragraph headed "Estate duty, tax and other indemnities" in Appendix IV to this prospectus.

## **Infringement of intellectual property rights**

The Group has certain registered patents and trademarks in the PRC. However, infringement of intellectual property rights by small enterprises, by way of counterfeiting products, does occur quite frequently in the PRC. The Group is not currently aware of any material infringement of the Group's intellectual property rights. Nonetheless, there can be no assurance that infringement can be kept under control at all time, and significant infringement could have a material adverse effect on the Group's operations.

The Group cannot ascertain that its products do not or will not infringe valid patents, copyrights or other intellectual property rights held by third parties. The Group may be subject to legal proceedings and claims from time to time relating to the intellectual property of others in the

# RISK FACTORS

ordinary course of its business. Intellectual property litigation is expensive and time consuming and successful infringement claims against the Group could result in substantial monetary liability or could materially disrupt the conduct of its business.

## Reliance on key management

The Group's success is, to a large extent, attributable to the continuous service of its executive Directors and senior management. The cessation of the involvement of any of these key executives in the management and operations of the Group or interruption of their full-time services to the Group may have a material and adverse impact on the Group. Although the Group has entered into fixed term service contracts with all of the executive Directors, namely Mr. Jiang Xiong, Mr. Jiang Qing and Mr. Chen Shu Quan, there is no assurance that the Group will be able to retain the services of such key executives in the future.

The Directors believe that the Group's future success depends on its ability to attract, retain and motivate highly skilled and experienced personnels. In addition, the Group's continued expansion will require an increase in the number of technical staff in the future. However, there is no assurance that the Group will be able to identify, attract, retain or train highly skilled staff with the right calibre in the future.

## Dividend policy

For the two years ended 31st December, 2001, the Group declared dividends of approximately RMB21.7 million (approximately HK\$20.5 million), RMB88.2 million (approximately HK\$83.2 million) respectively representing 52.4% and 94.0% of net profit of the respective year. There is, however, no assurance that future dividends will be paid at a similar level to past dividends and potential investors should be aware that the amount of dividends paid in the past should not be used as a reference or basis upon which future dividends are determined.

The declaration, payment and amount of the any future dividend of the Company will be subject to the discretion of the Directors, and will depend upon, among others, the Group's results of operations, cash flows and financial conditions, operating and capital requirements and other relevant factors prevailing and the time.

It is the Company's current intention to recommend annually the distribution to shareholders of about 30% of the Company's distributable annual earnings as cash dividends commencing from the first year after the Shares have been listed for a complete financial year. (If the Shares have not been listed for a complete financial year, dividend payment will be determined on a pro rata basis by making reference to an annual payout of 30% of the Company's distributable annual earnings). Such dividend policy may be amended where: (i) the cash available to the Company is in an amount lower than the above mentioned amount; and (ii) there is a negative impact on the cash flow of the Group due to the investments made by the Company as approved by the Directors which are not fully covered by appropriate financing. The amounts of dividends actually distributed to holders of the Shares will depend upon the Company's earnings and financial condition, operating requirements and capital requirements.

## RISKS RELATING TO THE INDUSTRY

### Competition

The markets for fire prevention and fighting equipment are highly competitive. Although new entrants providing or developing similar products and services will be required to obtain



# RISK FACTORS

Certificates of Conformity of Product Quality (產品質量認證證書) issued by CCCFP under the Ministry of Public Security (公安部), the Directors believe that the prosperity of the industry will attract new competitors. Upon the accession of China into the WTO, more foreign competitors will enter the PRC fire prevention and fighting equipment market with more competitive price strategies. These competitors may also respond to application of technologies and changes in customer requirements more quickly, take advantage of business opportunities more readily and adopt more aggressive pricing policies than the Group. The Group's business is expected to be subject to fierce competition from both the foreign and domestic manufacturers and this could have a material effect on the business and profitability of the Group.

## **Heavy reliance on the construction market in the PRC**

The fire prevention and fighting systems installation business of the Group relies heavily on the economic development, especially the construction sector in the PRC. Should activities in the construction market in the PRC fall or slow down, the turnover and profitability of the Group may be adversely affected.

The Group normally acts as the project manager on the installation of fire prevention and fighting system in a construction project and the Group normally receives fees in stages based on the percentage-of-completion of construction work. Construction projects may be adversely affected by a number of factors, including shortage of materials, price fluctuations, bad weather, natural disasters, accidents, downturns in the economic conditions and other unforeseeable situations or matters. Should any of these risks occur, the completion of the whole or part of a property development project may be postponed and consequently the receipt of the progress payment of fees by the Group may be delayed. Moreover, no compensation may be received as a result of such delay.

## **RISKS RELATING TO THE PRC**

### **Political and economic considerations**

The PRC economy is currently evolving from a planned economy into a market-oriented economy. Although the PRC has adopted an open door policy, changes in the policies of the PRC Government regarding the domestic economy (for example, changes affecting foreign exchange rates, inflation, taxation and trade) may have a material effect on the overall economy. The current reforms are unprecedented, produce effects that are unpredictable, and are subject to further refinement and improvement. New political, economic and social developments and considerations may lead the PRC Government to make adjustments to these reform measures. Such amendments and adjustments may not have a favorable effect on the Group's business. Any change, variation or adjustment to the reform measures taken by the PRC Government may have a material adverse effect on the business of the Group.

### **Changes in laws, regulations and policies**

The PRC legal system is a civil law system. Unlike the common law system, the civil law system is based on written statutes in which decided legal cases may have little precedential value. In 1979, the PRC began to promulgate a comprehensive system of laws and has since introduced many laws and regulations to provide general guidance on economic and business practices in the PRC and to regulate foreign investment. Progress has been made in the promulgation of laws and regulations dealing with economic matters such as corporate organisation and governance, foreign

# RISK FACTORS

investment, commerce, taxation and trade. The promulgation of new changes to existing laws and the abrogation of local regulations by national laws could have a negative impact on the business and prospects of the Group and its joint ventures. In addition, as these laws, regulations and legal requirements are relatively recent, their interpretation and enforcement involve significant uncertainty.

In the PRC, fire prevention and fighting systems installation and the manufacturing of fire prevention and fighting equipment business in urban areas are under the supervision of a number of government ministries and departments, including the Ministry of Construction (建設部), the Ministry of Fire Protection Public Security (公安部消防局) and the Ministry of Public Security (公安部). The Group must comply with the relevant requirements of certain regulations, including the Fire Services Law of the PRC (中華人民共和國消防法). In addition, the Group must comply with the relevant requirements and policies of local authorities where the Group's projects are situated.

There can be no assurance that the above regulatory regime and policies will not be changed. The Group's operations and profitability may be materially adversely affected if changes that occur are not favourable to the Group.

## **Changes in foreign exchange regulations**

Since 1996, the PRC Government has promulgated various foreign exchange rules, regulations and notices (the "Policies") to raise the convertibility of Renminbi. According to the Policies, a foreign-invested enterprise ("FIE") must open a "current account" and a "capital account" at a bank authorised to trade foreign exchange. A FIE may convert Renminbi in the capital account into any foreign currency at any authorised bank with the prior approval of the State Administration for Foreign Exchange ("SAFE").

The income and expenditures of the Group are denominated in Renminbi. At present, Renminbi cannot be freely converted into other currencies. According to the Policies, upon producing the board resolution on the authorisation of the distribution of profits or dividends or the commercial documents evidencing foreign exchange transactions, the Group may purchase the foreign exchange required for the distribution from a designated authorised bank. The Group cannot guarantee that the Policies will not be withdrawn or amended.

Although the new regulations have provided for the greater convertibility of the Renminbi, Renminbi is still not a freely convertible currency.

The Group does not currently have any foreign currency borrowing and foreign currency denominated purchases. After the completion of the Placing, the Group will also need foreign currency to meet the payment of any dividend declared by the Company. The Group's main operating subsidiary, Fujian Wanyou, receives all of its revenues in Renminbi. Fujian Wanyou is a wholly foreign-owned enterprise and hence, a FIE. It has been issued with "foreign exchange registration certificates" ("FERCs") by the local bureau of the SAFE and is entitled to buy foreign exchange at the currency clearing system of the relevant bank for remittance outside the PRC. As FERCs are reviewed annually, there is no assurance that Fujian Wanyou has the right to undertake foreign exchange transaction which may not be revoked or withdrawn. There is also no assurance that the Group will otherwise be able to obtain sufficient foreign exchange to meet its requirements (including as to the payment of dividends by the Company).

# RISK FACTORS

There can be no assurance that exchange rates will not become volatile or that the exchange rate of Renminbi against the U.S. dollar will not change in such a way as to affect the financial position of the Group. Exchange rate fluctuations may adversely affect the Group's financial performance.

Any devaluation of the Renminbi would increase the effective cost of the Group to satisfy its foreign currency requirements. Any such devaluation may also materially adversely affect the value, translated or converted into US or Hong Kong dollars, of the Group's net assets, its earnings and any declared dividends.

## **Currency and exchange fluctuations**

The value of Renminbi is subject to changes in the PRC Government's policies and depends to a large extent on domestic and international economic and political developments, as well as supply and demand in the local market. Since 1994, the official exchange rate for the conversion of Renminbi to US dollars has generally been stable, and Renminbi has appreciated slightly against the US dollar. However, given the economic instability and currency fluctuations in Asia in recent years, the Directors cannot give any assurance that the value of Renminbi will continue to remain stable against the US dollar or any other foreign currency.

Any devaluation of Renminbi may adversely affect the value of, and dividends payable on, the Shares in foreign currency since the Group receives its revenues and expresses its profits in Renminbi. Results of operations and the financial condition of the Group may also be affected by changes in the value of certain currencies other than Renminbi in which the Group's obligations are denominated. In particular, a devaluation of the Renminbi is likely to increase the portion of the Group's cash flow required to satisfy its foreign currency-denominated obligations.

## **ISSUES RELATING TO STATEMENTS MADE IN THIS PROSPECTUS**

### **Unofficial statistics**

Certain statistics relating to the fire prevention and fighting industry contained in this prospectus are derived from unofficial publications. Such information has not been independently verified by the Company and may be inaccurate, incomplete or not up to date. The Company makes no representation as to the correctness or accuracy of such statements or information. Therefore, investors should not rely heavily on such information.

# INFORMATION ABOUT THIS PROSPECTUS AND THE PLACING

## DIRECTORS' RESPONSIBILITY FOR THE CONTENTS OF THIS PROSPECTUS

This prospectus includes particulars given in compliance with the Companies Ordinance, the Securities (Stock Exchange Listing) Rules 1989 of Hong Kong (as amended) and the GEM Listing Rules for the purpose of giving information to the public about the Group.

This prospectus, for which the Directors collectively and individually accept full responsibility, includes particulars given in compliance with the GEM Listing Rules for the purpose of giving information with regard to the Group. The Directors, having made all reasonable enquiries, confirm that, to the best of their knowledge and belief:

- (a) the information contained in this prospectus is accurate and complete in all material respects and not misleading;
- (b) there are no other matters the omission of which would make any statement in this prospectus misleading; and
- (c) all opinions expressed in this prospectus have been arrived at after due and careful consideration and are founded on bases and assumptions that are fair and reasonable.

The Placing Shares are offered solely on the basis of the information contained and the representations made in this prospectus. No person in connection with the Placing is authorised to give any information or to make any representations that are not contained in this prospectus, and any information or representations not contained herein must not be relied upon as having been authorised by the Company, CPY, any of the Underwriters, any of their respective directors, or any other person involved in the Placing.

## FULLY UNDERWRITTEN

This prospectus is published solely in connection with the Placing which is fully underwritten by the Underwriters pursuant to the Underwriting Agreement. Further information relating to the underwriting arrangements is set out in the section headed "Underwriting" in this prospectus.

## PLACING SHARES TO BE OFFERED IN CERTAIN JURISDICTIONS ONLY

No action has been taken to permit the offering of the Placing Shares or the distribution of this prospectus in any jurisdiction other than Hong Kong. Accordingly, this prospectus may not be used for the purposes of, and does not constitute, an offer or invitation, nor is it calculated to invite or solicit offers to subscribe for or to purchase any Placing Shares in any jurisdiction other than Hong Kong and it is not an offer or invitation to subscribe for or to purchase any Placing Shares to any person to whom it is unlawful to make such an offer or invitation. The distribution of this prospectus and the offering of the Placing Shares in certain jurisdiction may be restricted by law.

### Singapore

This prospectus has not been and will not be registered as a prospectus with the Monetary Authority of Singapore (the "Authority"). Accordingly, this prospectus and any other document or materials in connection with the offer of the Placing Shares may not be issued, circulated or distributed in Singapore nor may any of the Placing Shares be offered for subscription or sold, directly or indirectly, nor may any invitation or offer to subscribe for or purchase any Placing

## INFORMATION ABOUT THIS PROSPECTUS AND THE PLACING

Shares be made directly or indirectly: to any member of the public in Singapore other than (a) to an institutional investor or other person specified in section 274 of the Securities and Futures Act 2001 of Singapore (“SFA”) (b) to a sophisticated investor, and in accordance with the conditions, specified in section 275 of the SFA, or (c) otherwise pursuant to, and in accordance with the conditions of, any other applicable provision of the SFA. The Authority takes no responsibility as to the contents of this prospectus.

### Cayman Islands

No offer of Placing Shares may be made, directly or indirectly, by or on behalf of the Company to the public in the Cayman Islands to subscribe for or acquire any of the Placing Shares.

### STABILISATION

In connection with the Placing, ICEA (on behalf of the Underwriters) may over-allocate up to an aggregate of 75,000,000 Shares, representing approximately 15 per cent. of the Placing Shares (such over-allocations may be covered by exercising the Over-allotment Option in full or in part, at any time up to 30 days from the date of this prospectus, by stock borrowing or by purchasing Shares in the secondary market) and/or effect transactions which stabilise or maintain the market price of the Shares at levels other than those which might otherwise prevail but which are not higher than the Issue Price. Any such over-allocation purchase and/or transactions will be made in compliance with all applicable laws and regulatory requirements.

Mr. Jiang Xiong has agreed with ICEA that he will make available to ICEA on a temporary basis by way of stock borrowing arrangements, up to a total of 75,000,000 Shares, to facilitate the settlement of over-allocations in connection with the Placing before the exercise of the Over-allotment Option.

ICEA may also on behalf of the Underwriters effect transactions which stabilise or maintain the market price of the Shares. Such transactions may be effected in all jurisdictions where it is permissible to do so, in each case, in compliance with all applicable laws and regulatory requirements. Such transactions, if commenced, may be discontinued at any time. Should stabilising transactions be effected in connection with the distribution of Shares, they will be done at the absolute discretion of ICEA.

Stabilisation is a practice used by underwriters in some markets to facilitate the distribution of securities. To stabilise, the underwriters may bid for or purchase, the newly issued securities in the secondary market, during a specified period of time, to retard and, if possible, prevent a decline in the initial issue price of the securities. The stabilisation price to cover over-allocations will not exceed the initial issue price.

In Hong Kong, such stabilisation activities on the Stock Exchange are restricted to cases where the underwriters purchase shares in the secondary market genuinely and solely for the purpose of covering over-allocations in the relevant offer. Such transactions, if commenced, may be discontinued at any time. The relevant provisions of the Securities Ordinance prohibit market manipulation in the form of pegging or stabilising the price of securities in certain circumstances.

# INFORMATION ABOUT THIS PROSPECTUS AND THE PLACING

## APPLICATION FOR LISTING ON THE GEM

Application has been made to the GEM Listing Committee of the Stock Exchange for listing of, and permission to deal in, the Shares in issue and the Shares to be issued pursuant to the Placing (including any Shares to be issued pursuant to the exercise of the Over-allotment Option or any options which may be granted under the Share Option Scheme). No part of the share capital or loan capital of the Company is listed on or dealt in any other stock exchange and no such listing or permission to deal is being or is proposed to be sought as at the date of this prospectus.

Pursuant to rule 11.23(l) of the GEM Listing Rules, at the time of listing and at all times thereafter, the Company must maintain the “minimum prescribed percentage” of 25 per cent. of the issued share capital of the Company in the hands of the public.

## COMMENCEMENT OF DEALINGS IN THE SHARES

Dealings in the Shares on the GEM is expected to commence on 30th September, 2002 and Shares will be traded in board lots of 5,000 each.

## SHARES WILL BE ELIGIBLE FOR ADMISSION INTO CCASS

Subject to the Stock Exchange granting the listing of, and permission to deal in, the Shares on the GEM and the compliance with the stock admission requirements of HKSCC, the Shares will be accepted as eligible securities by HKSCC for deposit, clearance and settlement in CCASS with effect from the date of commencement of dealings in the Shares on the GEM or any other date HKSCC chooses. Settlement of transactions between participants of the Stock Exchange is required to take place in CCASS on the second business day after any trading day.

Investors should seek the advice of their stockbroker or other professional advisers for details of those settlement arrangements as such arrangements will affect their rights and interests.

All activities under CCASS are subject to the General Rules of CCASS and the CCASS Operational Procedures in effect from time to time.

All necessary arrangements have been made for the Shares to be admitted into CCASS.

## PROFESSIONAL TAX ADVICE RECOMMENDED

Potential shareholders are recommended to consult their professional advisers if they are in any doubt as to the taxation implications resulting from subscribing for, purchasing, holding, disposing of and dealing in the Placing Shares. None of the Company, CPY, the Underwriters, any of their respective directors, agents or advisers or any other party involved in the Placing accepts responsibility for any tax effects on, or liability of, any person resulting from the subscription for, purchase, holding, disposing of or dealing in the Placing Shares. Only Shares registered on the Company’s branch register of members maintained in Hong Kong may be traded on the GEM.

# **INFORMATION ABOUT THIS PROSPECTUS AND THE PLACING**

## **HONG KONG BRANCH REGISTER AND STAMP DUTY**

All the Placing Shares will be registered on the Company's Hong Kong branch register of members to be maintained by Computershare Hong Kong Investor Services Limited in Hong Kong. Dealings in the Shares registered in the Company's Hong Kong branch register will be subject to Hong Kong stamp duty. The Company's principal register of members is maintained by Bank of Butterfield International (Cayman) Ltd. in the Cayman Islands.

## **STRUCTURE AND CONDITIONS OF THE PLACING**

Details of the structure of the Placing, including conditions of the Placing, are set out in the section headed "Structure and conditions of the Placing" in this prospectus.

# DIRECTORS AND PARTIES INVOLVED IN THE PLACING

## DIRECTORS

Name	Address	Nationality
<b>Executive Directors</b>		
JIANG Xiong (江雄)	Flat 941, 9th Floor Block D Metropole Building 416-430 King's Road North Point, Hong Kong	Chinese
JIANG Qing (江清)	34 Chang Shou She Tai Jiang District Fuzhou, PRC	Chinese
CHEN Shu Quan (陳樹泉)	28 Gu Ping Road Gu Lou District Fuzhou, PRC	Chinese
<b>Independent non-executive Directors</b>		
LIU Shi Pu (劉式浦)	Rm 1104, Block 13 2nd District Fang Gu Garden Fang Zhuang Fengtai District, Beijing PRC	Chinese
WONG Hon Sum (黃漢森)	Flat C, 10th Floor, Block 6 Sceneway Gardens Kwun Tong Kowloon Hong Kong	Canadian



# DIRECTORS AND PARTIES INVOLVED IN THE PLACING

## PARTIES INVOLVED

### Sponsor

Core Pacific – Yamaichi Capital Limited  
36th Floor, Cosco Tower  
Grand Millennium Plaza  
183 Queen’s Road Central  
Hong Kong

### Underwriters

Core Pacific – Yamaichi International (H.K.) Limited  
36th Floor, Cosco Tower  
Grand Millennium Plaza  
183 Queen’s Road Central  
Hong Kong

ICEA Capital Limited  
42nd Floor, Jardine House  
1 Connaught Place  
Central, Hong Kong

CLSA Limited  
18th Floor, One Pacific Place  
88 Queensway, Hong Kong

Karl-Thomson Securities Company Limited  
Room 801, Tower One  
Lippo Centre  
89 Queensway, Hong Kong

Nomura International (Hong Kong) Limited  
20th Floor, Asia Pacific Finance Tower  
Citibank Plaza, 3 Garden Road  
Central, Hong Kong

Phoenix Capital Securities Limited  
Room 3203-4, Edinburgh Tower  
The Landmark  
15 Queen’s Road Central  
Hong Kong

Sun Hung Kai International Limited  
12th Floor, One Pacific Place  
88 Queensway, Hong Kong

The Bank of East Asia, Limited  
8th Floor, The Bank of East Asia Building  
10 Des Voeux Road Central  
Hong Kong

## DIRECTORS AND PARTIES INVOLVED IN THE PLACING

### **Legal advisers to the Company**

*As to Hong Kong Law:*  
Sidley Austin Brown & Wood  
49th Floor  
Bank of China Tower  
1 Garden Road  
Central  
Hong Kong

*As to Cayman Islands Law:*  
Conyers Dill & Pearman, Cayman  
Century Yard  
Cricket Square  
Hutchins Drive  
George Town  
Grand Cayman  
British West Indies

*As to PRC Law:*  
Chen & Co. Law Firm  
Suite 1901, North Tower  
Shanghai Stock Exchange Building  
528 Pudong Nan Road  
Shanghai 200120  
PRC

### **Legal advisers to the joint global coordinators and sponsor and to the Underwriters**

*As to Hong Kong Law:*  
Woo, Kwan, Lee & Lo  
27th Floor, Jardine House  
1 Connaught Place  
Central  
Hong Kong

### **Auditors and reporting accountants**

Deloitte Touche Tohmatsu  
*Certified Public Accountants*  
26th Floor  
Wing On Centre  
111 Connaught Road Central  
Hong Kong

### **Property valuer**

Greater China Appraisal Limited  
Room 2407  
Shui On Centre  
6-8 Harbour Road  
Wanchai  
Hong Kong

## CORPORATE INFORMATION

<b>Registered office</b>	Century Yard Cricket Square Hutchins Drive P.O. Box 2681 GT George Town Grand Cayman British West Indies
<b>Head office and principal place of business in PRC</b>	8th Floor, Gaojing Trade Centre No. 158 Wu Yi Bei Road, Fuzhou City Fujian Province, PRC
<b>Principal place of business in Hong Kong</b>	Units 6-7, Office B, 5th Floor K. Wah Centre No. 191 Java Road North Point Hong Kong
<b>Company website</b>	<a href="http://www.wanyoufire.com">www.wanyoufire.com</a>
<b>Company secretary</b>	CHAN Siu Tat <i>ACCA/AHKSA</i>
<b>Qualified accountant</b>	CHAN Siu Tat <i>ACCA/AHKSA</i>
<b>Compliance officer</b>	JIANG Qing
<b>Audit committee</b>	LIU Shi Pu WONG Hon Sum
<b>Authorised representatives</b> <i>(for the purpose of the GEM Listing Rules)</i>	JIANG Qing CHAN Siu Tat
<b>Principal share registrar and transfer office</b>	Bank of Butterfield International (Cayman) Ltd. Butterfield House 68 Fort Street P.O. Box 705 George Town Grand Cayman Cayman Islands
<b>Hong Kong branch share registrar and transfer office</b>	Computershare Hong Kong Investor Services Limited 17th Floor Hopewell Centre 183 Queen's Road East Hong Kong
<b>Principal banker</b>	Agricultural Bank of China Fuzhou Taijiang Sub branch 福州台江區下杭路52號 Fujian 350009, PRC

# INDUSTRY OVERVIEW

The information provided in this section and elsewhere in this prospectus relating to the industry background is derived from various publications, including newspaper reports. This information has not been independently verified by the Group, the Underwriters or any of their respective advisors and should not be unduly relied upon. The Directors confirm that, to the best of their knowledge and belief, such information has been accurately extracted and any opinions or comments herein based on the public information are reasonable.

## FIRE HAZARDS IN THE WORLD AND THE PRC

Fire hazard is the most frequently occurred hazard in the world, which happens somewhere in the world everyday. Most of the fire hazards are caused by human factors whilst earthquakes, droughts, lightning and other natural disasters can also cause serious fire hazards. Therefore, fire hazards can be said to be both natural disasters and human disasters.

## THE WORLD'S FIRE HAZARDS

According to an article, namely “Prospects of the New Century Fire Prevention Science & Technology” (“新世紀消防科學技術展望”) published by “Fire Prevention Technique and Products Information” (“消防技術與產品信息”) in March 2001, a statistical study conducted by the World Fire Statistics Centre of the United Nations in a recent year reported that there are about six to seven million cases of fire accidents each year in the world causing death of approximately 65,000 to 75,000 persons. The following tables set out some fire statistics in the mid-90s in the world:

### Fire statistics by continent

Country	Population (million)	Number of fire hazards (million/year)	Number of casualties (thousand/year)
Europe	695.4	2	220
Asia	3,474.6	1	300
North America	454.2	2.3	60
South America	318.6	0.3	25
Africa	735.0	0.7	75
Australia	29.7	0.1	3
Total	<u>5,707.5</u>	<u>6.4</u>	<u>683</u>

# INDUSTRY OVERVIEW

## THE PRC'S FIRE HAZARDS

According to an article, namely “Prospects of the New Century Five Prevention Science & Technology” (“新世紀消防科學技術展望”) published by “Fire Prevention Technique and Products Information” (“消防技術與產品信息”) in March 2001, during the 50 years from 1950 to 1999, there were, in aggregate, 3,258,105 fire hazards (excluding fire hazards in forest, grassland, mines, beaches, aeroplanes and military fires), which caused death of 165,499 persons, casualty of 313,766 persons and direct economic losses of RMB182.82 billion. The losses caused by fire are tremendous. The table below sets out some other statistics of fire hazards in the PRC from 1950 to 1999.

Year	1950-1954 (RMB million)	1955-1959 (RMB million)	1960-1964 (RMB million)	1965-1969 (RMB million)	1970-1974 (RMB million)
Economic loss	255.60	359.09	847.18	508.77	1,166.29
Casualty (person)	14,431	55,375	48,546	30,752	46,357
Death (person)	4,997	23,643	31,061	13,939	19,843

Year	1975-1979 (RMB million)	1980-1984 (RMB million)	1985-1989 (RMB million)	1990-1994 (RMB million)	1995-1999 (RMB million)
Economic loss	1,262.61	961.51	2,261.17	4,109.22	5,890.10
Casualty (person)	41,403	15,550	18,297	22,271	19,538
Death (person)	23,816	12,181	11,415	11,357	11,112

From the statistics shown in the above table, it is discovered that the economic losses caused by fire hazards grew with the development of the PRC economy. The table below sets out the trend of the main causes of fire hazards in the PRC from 1978 to 1999:

### Main causes of fire hazards in the PRC from 1978 to 1999

Year	1978	1979	1980	1981	1982	1983	1984	1985	1986	1987	1988	1989	1990	1991	1992	1993	1994	1995	1996	1997	1998	1999
Arson	2.5	2.1	2.9	4.4	4.9	5.6	5.5	5.1	5.3	5.9	6.7	9.4	10.6	10.7	10.3	9.1	9	9.4	8.8	6.3	6.1	6
Use of electricity	5.7	6.4	7.3	8.8	9.9	11.1	12	14.9	17.5	19.5	19.5	21.6	23.7	20.2	22.1	24.6	26.9	28	28.5	26.5	27.5	22.8
Violation of safety regulation	7.6	7	10.1	10.2	11.2	10.4	10	10.1	9.9	10.8	10.2	11.1	17.9	15.3	15.6	16.2	16.5	16.8	16.1	7.2	7.1	5.4
Improper usage of fire	57.3	56.6	44.6	41.6	40.3	37.7	39.3	36.9	34.1	32.2	31.5	27.5	21.8	21.2	20.1	19.8	18.2	17.2	17.4	24.9	25.5	26.2
Play with fire	5.5	6.8	11.6	10.8	10	9.2	7.9	9.6	7	6.5	9.5	17.6	17	15.4	13.8	11	11.2	10.6	9.4	8.6	8.1	6.4

Due to the increase in fire hazards caused by the use of electricity and a significant portion of fire hazards caused by the violation of safety regulation, this indicates that fire safety works (including governmental administrative fire safety work and public fire safety education work) are important and that the enhancement of fire prevention and fighting technologies and facilities are essential.

According to an article, namely “Fire Safety Works for 2000” (“2000年消防工作”) published at the website of the Ministry of Public Security, there were 189,000 fire hazards in 2000 causing death of 3,210 persons, casualty of 4,404 persons and direct economic loss of RMB1.52 billion.

# INDUSTRY OVERVIEW

Researches and reports suggest that fire hazards in the PRC nowadays are concentrated in urban areas where public locations, such as shopping malls and restaurants, industrial buildings, transportation facilities, telecommunication hubs, high-rise buildings and underground constructions are frequently threatened by fire hazards. The major reasons for a high occurrence of fires in urban areas are as follows:

1. As the economy develops, the application of electricity, heat and gas increase. The improper usage of this energy causes fire hazards.
2. The lack of and under-equipped fire safety facilities and fire fighting equipment fail to suppress fire promptly and intensify the degree of fire. According to the figures provided by the Ministry of Public Security, it should be equipped with 2,655 fire services stations, 366,953 fire hoses and 8,734 fire engines in 266 cities in the country. However, there were only 1,548 fire services stations, 259,820 fire hoses and 6,893 fire engines in place. The insufficiency rate is as high as 20-40%.
3. The insufficient and ineffective education on people's mentality and obligations towards fire safety contribute to even higher economic losses in fire hazards.

In summary, accompanied by the economic development in the PRC, fire hazards will threaten the safety of the society. The development of fire prevention and fighting equipment, and increased public awareness on the danger of fire hazards are fundamental in ensuring the fire safety of the society.

## THE FIRE PREVENTION AND FIGHTING INDUSTRY IN THE PRC

### Development of fire prevention and fighting product industry in the PRC

According to an article, namely "Trends and Strategies of PRC Fire Safety Products Market after Accession into the WTO" ("加入WTO後我國消防產品市場的形勢與對策") published by "Fire Prevention Technique and Products Information" ("消防技術與產品信息") in May 2001, during the early stage of open door reform in the early 1980s, there were only about 100 enterprises engaged in the fire prevention and fighting products manufacturing sector. In mid-1980s numerous small-scale production operators entered into the industry and around 100 types of products under 6 to 7 categories were domestically produced. In 1990s, the fire prevention and fighting product market experienced a significant growth. In 1995, there were more than 1,800 fire prevention and fighting product production enterprises in the PRC which are capable of producing more than 300 types of fire prevention and fighting products under 20 categories, with over 3,000 specifications.

## Categories of fire prevention and fighting products

1. Fire engines
2. Fire pumps
3. Fire extinguishing agents
4. Fire extinguishers
5. Fire plugs
6. Fire inlets
7. Fire hoses
8. Fire guns and monitors
9. Fire doors
10. Fire alarm equipment
11. Sprinkler fire extinguishing equipment
12. Foam extinguishing equipment
13. Gas extinguishing equipment
14. Water supply equipment
15. Rescue equipment
16. Firemen equipment
17. Fire retardant materials
18. Fire-proof structure components for constructions
19. Other fire related products

According to an article, namely “Trend of Development for Fire Safety Products Market and Fire Protection Industry in the PRC” (“中國的消防產品市場與消防產業發展趨勢”) published by “Fire Prevention Technique and Products Information” (“消防技術與產品信息”) in August 2001, the industry employs about 1 million people with an average annual output value in excess of RMB20 billion. The nature of enterprises has also evolved from solely state-owned, collective ownership to joint-stock, sino-foreign joint venture and private enterprises.

## Fire alarm equipment sector

According to an article, namely “China Fire Alarm Industry Facing the Challenges from the WTO” (“中國消防報警產業正視WTO”) in the “Proceedings of the Fortune 30 in the Fire Protection Industry” (“消防產業30強論壇報告集”) issued by CFPA in July 2001, in the fire alarms system category, there are currently about 100 domestic manufacturers, coupled with about 30 foreign enterprises selling fire alarm products in the PRC. The total number of detectors sold in the PRC exceeds 3 million per annum.

## Laws and regulations for the industry and market access

The Fire Service Regulations (中國消防條例) and the Fire Services Law of the PRC (中華人民共和國消防法), which were promulgated in 1984 and 1998 respectively, classified fire prevention and fighting products into the category of safety products. This has facilitated the publication of a complete set of regulations and standards and laid a solid foundation for the continual development of fire prevention and fighting products. Currently, there are 209 fire service national and industry standards (國家標準及行業標準), out of which 180 are mandatory (強制性標準) and 29 are recommended (推薦性標準), together with 26 rules issued at the ministerial levels (部頒規章) in the PRC. The construction of fire service legislation has warranted a regulated development of the fire service product market.

# INDUSTRY OVERVIEW

Regulations governing fire prevention and fighting enterprises in the PRC currently comprise four procedural requirements, namely market access (準入制度), supervision and sample testing (監督抽查制度), the quality reporting (質量通報制度) and dissemination of information on quality (質量信息發佈制度).

Pursuant to the relevant provisions of the Product Quality Law (產品質量法) and the Fire Service Law of the PRC (中華人民共和國消防法), fire prevention and fighting products distributed in the PRC market, both domestic and imported, shall comply with the relevant regulations for the fire service product market. The market access requirements for domestic products are regulated by four systems of administration, namely the system of fire engine catalogue (消防車目錄制度), the system of production permits (生產許可證制度), the system of conformity of product quality (認證制度) and the system of mandatory testing (強制檢驗制度). The market access requirements for foreign imported products are regulated by two systems of administration, namely, the system of conformity of product quality (認證制度) and the system of mandatory testing (強制檢驗制度). Under the system of fire engine catalogue (消防車目錄制度), the qualified production enterprises and the respective products of vehicles, civilian refitted vehicles or motorcycles are listed on the national catalogues published by the State Machinery Industry Bureau and the Ministry of Public Security for that year. The system of production permits (生產許可證制度) gives the Ministry of Public Security the authority to issue the national production permit for industrial products (全國工業產品生產許可證證書) for any qualified fire prevention and fighting product. According to the system of conformity of product quality, China Certification Committee for Fire Prevention Products Quality (中國消防產品質量認證委員會) will issue the Certificate of Conformity of Product Quality (產品質量認證證書) to a qualified fire prevention and fighting product. The system of mandatory testing (強制檢驗制度) states that the PRC Quality Control Testing Centre will perform “model” tests on fire prevention and fighting products and products can be sold in the PRC after having passed the tests. The four systems of administration cover all types of fire prevention and fighting product. Any fire prevention and fighting product is permitted to be sold in the PRC if it satisfies any one of the above four systems and the Ministry of Public Security (公安部) determines which category of fire prevention and fighting product is governed by which system of administration. For imported fire prevention and fighting products, they are regulated by two systems of administration, namely, the system of conformity of product quality and the system of mandatory testing (強制檢驗制度), which are the same systems as those of the domestic ones. Similar to domestic fire prevention and fighting products, any imported fire prevention and fighting product is permitted to be sold in the PRC if it satisfies any one of the two systems.

## **Fire prevention and fighting systems installation projects (消防安裝工程) in the PRC**

Construction of various high-rise and multi-storey buildings is developing rapidly. These types of construction set new requirements in respect of structure, water supply, gas extinguishing and electrical installation that require sophisticated fire prevention and fighting systems and maintenance to protect human lives and property.

According to “Handbook for Fire Prevention and Fighting System Project Installations in the PRC” (中國消防工程手冊), the aspects of fire prevention and fighting systems installation projects, in general, include the followings:

- Fire prevention and fighting systems installation projects of backbone infrastructure for a region which include mainly master plans (總體佈局), water supply (給水), fire lanes (消防車道), fire service patrols (stations) (消防隊(站)) and fire service communications (消防通訊);



## INDUSTRY OVERVIEW

- Fire prevention and fighting systems installation projects for various types of industrial buildings;
- Fire prevention and fighting systems installation projects for commercial, public and residential buildings; and
- Fire prevention and fighting systems installation and modification projects for old buildings.

There are currently 1,500 enterprises providing fire prevention and fighting systems installation in the PRC. As a relatively new industry, the features of fire prevention and fighting systems installation industry are set out below:

- *Quality of different contractors vary in accordance with ones' experience and quality control measures*
- *Absence of national brand name in fire prevention and fighting systems installation as most of the enterprises providing fire prevention and fighting systems installation services are regional or provincial in nature*
- *Few contractors integrate installation services with product manufacturing*
- *Contractors offer insufficient or inefficient after-sales services*

### **Administration of fire prevention and fighting systems installation projects**

Pursuant to the “Provisional Measures Regarding the Supervision and Administration of Automated Fire Prevention and Fighting System Project Installations in Fujian Province” (《福建省自動消防系統工程施工監督管理暫行規定》) commencing on 1st October, 1994, the installation, testing, commissioning and maintenance of automated fire prevention and fighting system projects must be undertaken by enterprises that have undergone the professional fire prevention and fighting technique training and passed such examination conducted by the provincial public security fire supervisory authorities and obtained installation permits. Those enterprises that have not been approved or obtained permits issued by the provincial public security fire supervisory authorities are prohibited from undertaking any automated fire prevention and fighting system project installations. An automated fire prevention and fighting project (自動消防系統工程) comprises the automated fire alarm system (火災自動報警系統), the automated sprinkler fire extinguishing system (自動噴水滅火系統); the foam fire extinguishing system (泡沫滅火系統); the halide, carbon dioxide and dry powder fire extinguishing system (鹵代烷、二氧化碳和乾粉固定滅火系統) and the interactive fire prevention and fighting control system (消防聯動控制系統) (including mechanical smoke prevention and exhaustion (機械防排煙), automated fire resistant doors (電動防火門), fire shutters (防火卷簾), fire broadcasts (消防廣播), emergency lightings (事故照明), evacuation indication control and display systems (疏散指示控制和顯示系統)). Automated fire prevention and fighting system project installation enterprises are classified into three categories with related scope of installation according to their respective technical capabilities (技術力量), level of equipment (裝備水平) and quality of installation (施工質量).

# INDUSTRY OVERVIEW

## Related scope of installation for each category of automated fire prevention and fighting system project installation enterprises 各類自動消防系統工程施工單位的相應施工範圍

Category of Enterprises 企業類別	Scope of contracting works 承包工程範圍
Category 1 installation enterprises	Undertake all kinds of automated fire prevention and fighting system installation projects
Category 2 installation enterprises	Undertake the following automated fire prevention and fighting system installation projects: <ul style="list-style-type: none"><li>– automated fire alarm system;</li><li>– automated sprinkler fire extinguishing system;</li><li>– foam fire extinguishing system;</li><li>– interactive fire prevention and fighting control system (including mechanical smoke prevention and exhaustion, automated fire resistant doors, fire shutters, fire broadcasts, emergency lightings, evacuation indication control and display systems)</li></ul>
Category 3 installation enterprises	Undertake the following automated fire prevention and fighting system installation projects of Class Two high-rise civil buildings with elevation below 32 metres and industrial buildings with Type C fire hazard level or below: <ul style="list-style-type: none"><li>– automated fire alarm system;</li><li>– automated sprinkler fire extinguishing system;</li><li>– foam fire extinguishing system;</li><li>– interactive fire prevention and fighting control system (including mechanical smoke prevention and exhaustion automated fire resistant doors, fire shutters, fire broadcasts, emergency lightings, evacuation indication control and display systems)</li></ul>

### Future development of fire prevention and fighting systems installation in the PRC

Fire prevention and fighting industry is a special industry relating to public safety. Enterprises providing “one-stop” solutions on manufacturing fire prevention and fighting products, providing fire prevention and fighting systems installation and maintenance services will be the key for success on the future development of the industry. According to the information provided by the PRC Fire Prevention and Fighting Association, there are, at present, not more than 5 enterprises in the PRC integrating both fire prevention and fighting product manufacturing and fire prevention and fighting systems installation. With intense competition, the Directors believe that corporate acquisitions and mergers will be the special features of the fire and prevention industry in the PRC and it is expected that a few enterprises with the capacity to manufacture high-end products, provide high quality installation services and nationwide maintenance services will have better opportunities to gain more market share.

# INDUSTRY OVERVIEW

## MARKET POTENTIAL

The Directors believe that the economy together with the property market in China will continue to grow in the foreseeable future and this will create significant demand for fire prevention and fighting systems. The Directors also believe that the State will continuously strengthen the enforcement of laws and regulation relating to fire prevention and fighting. In addition, the Directors consider that new opportunities will arise from the budget of fire service product supplies earmarked for the fire service departments in every city in the PRC. By capitalising on the existing advantageous position, the Group is confident of being able to capture a significant portion of the future market potential in China owing to the factors set out as follows:–

### Tightening of laws and regulations

“The Fire Services Law of the PRC (中華人民共和國消防法)” was promulgated in 1998 and has set a proper legal framework to enhance fire safety. Section 8 of the Fire Services Law requires governments of different cities to include the implementation of fire prevention and fighting equipment as part of the city planning. In addition, it also promotes the governments to put more funds on the development of fire prevention and fighting technology and the application of advanced fire prevention and fighting equipment. Hence, the development of the fire prevention and fighting industry has been experiencing a continuous growth. The Administrative Office of the Fire Prevention and Fighting Product Industry (消防產品行業管理辦公室) under the Ministry of Public Security has concerns over the development of the industry. It has set policies for the industry and reforms in the regulatory system of fire prevention and fighting products. It has also established a nationwide network relating to the quality of fire prevention and fighting products and gradually implemented the system of conformity of product quality and conformity of fire prevention and fighting product model. According to “Fire Protection Weekly Journal under the China Public Security Daily” (“人民公安報消防周刊”), the fire prevention and fighting industry in the PRC will grow significantly at an annual growth rate of 15% to 20% and the annual total value of production for the next five years will be approximately RMB35 billion to RMB40 billion.

In addition to rectification of the existing fire prevention and fighting systems, the Fire Services Law and regulations have also imposed stringent requirements for repair and maintenance of the existing fire prevention and fighting systems. As public fire prevention and fighting facilities require annual repair and maintenance, RMB9 billion will be spent on repair and maintenance of fire prevention and fighting systems in the PRC per annum according to “Fire Protection Weekly Journal under the China Public Security Daily” (“人民公安報消防周刊”).

### New projects accompanied by new construction developments

According to the Tenth Five Year Plan of the PRC Central Government, the total gross floor area for residential buildings in cities and villages during the next five years is estimated to be 5,700 million sq.m., including 2,700 million sq.m. for residential buildings in cities and 3,000 million sq.m. for residential buildings in villages. In addition, the total gross floor area for newly constructed buildings in cities is estimated to be 5,000 million sq.m. during the next five years and qualified fire services installation must be installed in all newly erected buildings. An extract from “Fire Protection Weekly Journal under the China Public Security Daily” (“人民公安報消防周刊”), states that, assuming that the budget for fire prevention and fighting systems installation is around RMB100-150 per sq.m. in accordance with the market practice of property development, the total market value will be approximately RMB50-75 billion in the PRC during the next 5 years.

# INDUSTRY OVERVIEW

## Government promotion

With the continued and rapid growth of the PRC economy, the degree of urbanisation and industrialisation has been increasing rapidly. All levels of government in the PRC have placed significant concerns over the development of fire safety and investments in urban fire prevention and fighting systems installation are increased accordingly. In addition, many new industrial, commercial, cultural and sports facilities are being constructed in all major cities in recent years and these facilities have different requirements on fire prevention and fighting systems. According to “Fire Protection Weekly Journal under the China Public Security Daily” (“人民公安報消防周刊”), approximately RMB200 billion will be spent in building facilities for the 2008 Olympic Games in Beijing and projects for fire services installation will account for 6%-11% of the total budget which is equivalent to about RMB12-22 billion based on industrial estimate. The Directors believe that the potential is enormous in the PRC.

## Modernisation of equipment for fire services departments

Accompanied with the robust growth in the economy and the increasing demands of society, the Directors believe that quality of the equipment for fire services departments in different areas in the PRC has been improving. To further enhance the level of equipment to an advanced international standard, different governments of provinces and cities in the PRC have been earmarking considerable budgets for the purchase of fire service product supplies to fire stations. In particular, the fire service departments at all levels of government in the PRC purchase fire prevention and fighting equipment and supplies of approximately RMB3 billion each year. The Directors believe that supplying equipment to fire services department will provide opportunities to the Group.

# GENERAL OVERVIEW OF THE GROUP

## GROUP STRUCTURE

On 20th September, 2002, the Group completed a reorganisation in preparation for the listing of its Shares on the GEM. As a result, the Company became the holding company of the Group. The following chart sets out the shareholding structure and the companies comprising the Group immediately following the completion of the Placing (assuming the Over-allotment Option is not exercised):

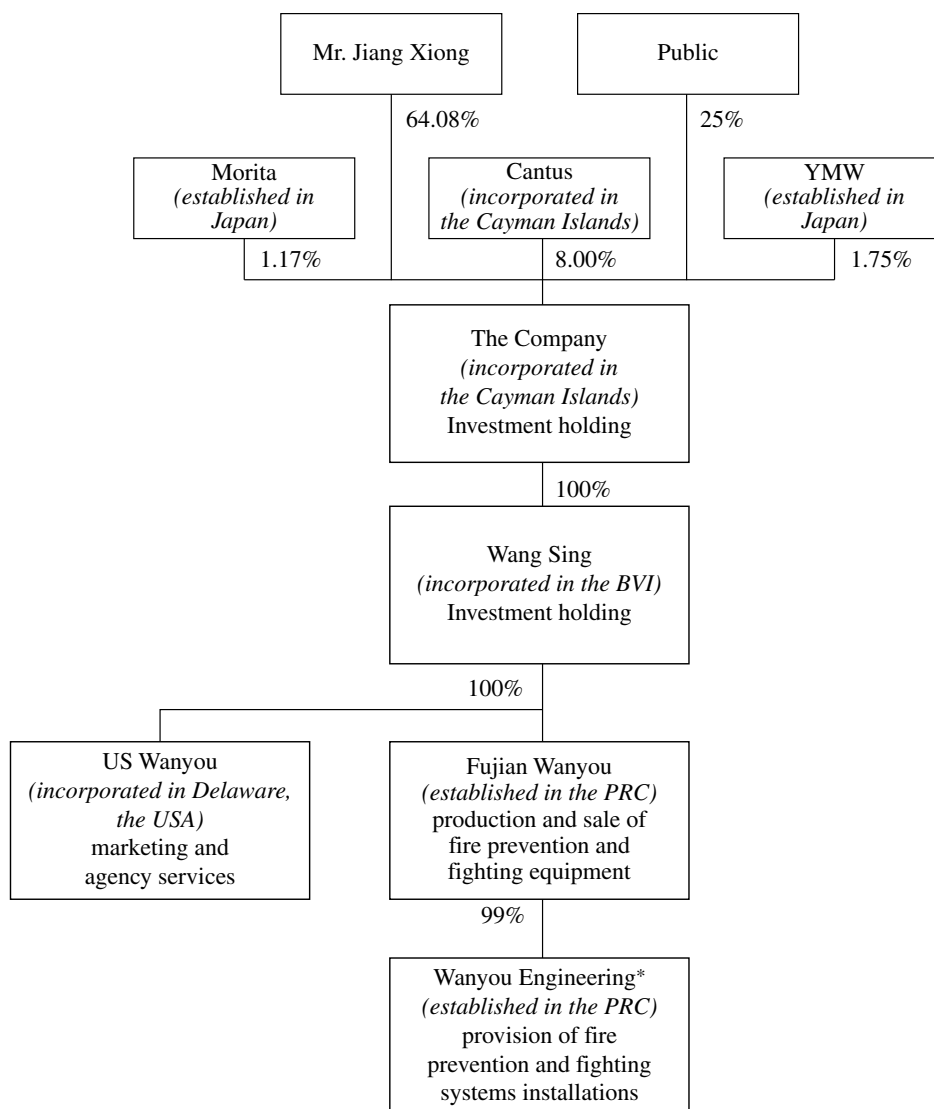

\* The remaining 1% shareholding is owned by Ms. Liu Mei Jin (劉梅金), a merchant engaged in trading business in the PRC and a third party who is independent of any of the executive Directors, chief executives, Substantial Shareholder or Initial Management Shareholder of the Group or their respective associates.

Note:

- As part of the Reorganisation, Mr. Jiang Xiong sold his interests in Wang Sing to the Company in exchange for the allotment and issue of 1,381,599,990 Shares, credited as fully paid, to him. Further details of the Reorganisation are set out in the paragraph headed "Corporate reorganisation" in Appendix IV to this prospectus. Immediately following the completion of the Placing, the number of Shares held by Mr. Jiang Xiong will be 1,281,600,000.

## GENERAL OVERVIEW OF THE GROUP

2. Cantus, an investment company, is a wholly-owned subsidiary of Aria, a pan-Asian private equity fund managed by CLSA Private Equity Management Limited. CLSA Private Equity Management Limited is a specialist private equity investment management firm focused on Asian equity investment and belongs to the CLSA Emerging Markets Group. On 1st March, 2002, Cantus was issued 1,000 shares in the capital of Wang Sing, a wholly-owned subsidiary of the Company, pursuant to a share subscription agreement dated 27th February, 2002 entered into between Cantus, Mr. Jiang Xiong and Wang Sing, at a consideration of approximately HK\$40,000,000, whose shares were subsequently exchanged for 160,000,000 Shares after the Reorganisation. The 160,000,000 Shares are indirectly held by Aria via its direct interest in Cantus.

Save as disclosed in this note and the paragraph headed “Strategic Investors” under the section headed “General overview of the Group” in this prospectus, none of the directors or shareholders of Cantus are connected with the Directors, Initial Management Shareholder, Substantial Shareholder, the chief executives and/or the respective associates of the Company.

Please also refer to the section headed “Substantial shareholder, initial management shareholder, significant shareholder and other shareholders” in this prospectus.

3. YMW is a Japanese-based investment fund which is managed by Yamaichi Hands-on Associates Inc., a professional management company founded at the end of 2000. On 1st March, 2002, YMW was issued 219 shares in the capital of Wang Sing, a wholly-owned subsidiary of the Company, pursuant to a subscription agreement dated 27th February, 2002 entered into between YMW, Mr. Jiang Xiong and Wang Sing, at a consideration of approximately HK\$8,745,900, whose shares were subsequently exchanged for 35,040,000 Shares after the Reorganisation.

Each of YMW, Cantus and Morita entered into a separate subscription agreement with Wang Sing and Mr. Jiang Xiong on 27th February, 2002 on substantially the same terms to subscribe for shares of Wang Sing, and, following commercial negotiations, YMW agreed to the restrictions on disposal of its Shares as if it were a Significant Shareholder.

Save as disclosed in this note and the paragraph headed “Strategic Investors” under the section headed “General overview of the Group” in this prospectus, none of the directors or fundholders of YMW are connected with the Directors, Initial Management Shareholder, Substantial Shareholder, the chief executives and/or the respective associates of the Company.

Please also refer to the section headed “Substantial shareholder, initial management shareholder, significant shareholder and other shareholders” in this prospectus.

4. Morita is a company engaged in the manufacturing and distribution of fire engines and fire prevention vehicles which is listed on the Osaka Stock Exchange Limited and Tokyo Stock Exchange Limited. The market capitalisation of Morita as at the Latest Practicable Date is approximately JPY18,512.35 million, equivalent to approximately HK\$1,203.30 million. On 1st March, 2002, Morita was issued 146 shares in the capital of Wang Sing, a wholly-owned subsidiary of the Company, pursuant to a subscription agreement dated 27th February, 2002 entered into between Morita, Mr. Jiang Xiong and Wang Sing, at a consideration of approximately HK\$5,830,600, whose shares were subsequently exchanged for 23,360,000 Shares after the Reorganisation.

Each of Morita, Cantus and YMW entered into a separate subscription agreement with Wang Sing and Mr. Jiang Xiong on 27th February, 2002 on substantially the same terms to subscribe for shares of Wang Sing, and, following commercial negotiations, Morita agreed to the restrictions on disposal of its Shares as if it were a Significant Shareholder.

Save as disclosed in this note and the paragraph headed “Strategic Investors” under the section headed “General overview of the Group” in this prospectus, none of the directors or substantial shareholders of Morita are connected with the Directors, Initial Management Shareholder, Substantial Shareholder, the chief executives and/or the respective associates of the Company.

Please also refer to the section headed “Substantial shareholder, initial management shareholder, significant shareholder and other shareholders” in this prospectus.

# GENERAL OVERVIEW OF THE GROUP

## HISTORY AND ACTIVE BUSINESS PURSUITS

### History

Fuzhou Wanyou Electrical Appliances Industrial and Trading Company Limited (福州萬友電器工貿有限公司), the predecessor of the Group, was a private-owned enterprise established in the PRC with limited liability and registered capital of RMB800,000. It was founded by i) Mr. Jiang Xiong who held 37.5% equity interest, ii) Mr. Jiang Shi Kai, Mr. Jiang Xiong's father, who held 2.5% equity interest and iii) Mr. Lu Zhen Chan, a relative of Mr. Jiang Xiong who held the remaining 60% equity interest in December 1993 and was engaged in the manufacturing and sales of electronic parts. Mr. Jiang Xiong began developing the fire fighting emergency lighting product business, after having envisaged that fire prevention and fighting equipment has great market potential in the PRC and the production permit was obtained in April 1995. On 5th September, 1995, Fuzhou Wanyou Electrical Appliances Industrial and Trading Company Limited (福州萬友電器工貿有限公司) changed its name to Fuzhou Wanyou Fire Prevention and Fighting Equipment Industrial and Trading Company Limited (福州萬友消防設備工貿有限公司). Since then, the Group started to develop, manufacture and sell fire prevention and fighting equipment under the leadership of Mr. Jiang Xiong. The first type of fire prevention and fighting equipment developed and produced by the Group was fire fighting emergency lighting (多功能消防應急燈), which received a "Gold Award in the 95 Science & Technology Achievement for Fujian Youth Expo" ("95 福建青年科技成果博覽會金獎") in November 1995. During the same period, the Group also set up a retail outlet in Fuzhou that sold fire prevention and fighting products developed by the Group. In addition, the Group developed a "multi-functional fire fighting fluorescent emergency lamp" (多功能消防應急螢光燈) which received a "Special Gold Award in the Fifth China Patent New Technology and New Products Expo" ("第五屆中國專利新技術新產品博覽會特別金獎") in April 1996.

The business of the Group grew rapidly particularly through the sales of fire-fighting emergency lamps and later expanded into the manufacture and sale of other types of fire prevention and fighting equipment. In May 1996, the Group obtained the "fire prevention and fighting system installation permit" Class 2 temporary certificate (自動消防系統工程施工認可証暫定二類) and commenced its fire prevention and fighting systems project. In an attempt to further expand the business of the Group, the Jiang's family raised the capital base of Fuzhou Wanyou Fire Prevention and Fighting Equipment Industrial and Trading Company Limited (福州萬友消防設備工貿有限公司). On 9th June, 1996, Mr. Lu Zhen Chan transferred all his interests in Fuzhou Wanyou Fire Prevention and Fighting Equipment Industrial and Trading Company Limited (福州萬友消防設備工貿有限公司) at a value of RMB480,000, being his cost of investment, to Mr. Jiang Qing. On 25th June, 1996, the registered capital of Fuzhou Wanyou Fire Prevention and Fighting Equipment Industrial and Trading Company Limited (福州萬友消防設備工貿有限公司) was increased to RMB1,000,000 with an additional sum of RMB200,000 paid by Mr. Jiang Xiong. As a result, Mr. Jiang Xiong and Mr. Jiang Qing held 50% and 48% equity interest in Fuzhou Wanyou Fire Prevention and Fighting Equipment Industrial and Trading Company Limited (福州萬友消防設備工貿有限公司), respectively, and took over the management of the company. The remaining 2% equity interest was held by Mr. Jiang Shi Kai who ceased to be involved in the management of Fuzhou Wanyou Fire Prevention and Fighting Equipment Industrial and Trading Company Limited (福州萬友消防設備工貿有限公司) in May 1996 and became a non-executive director of the company until he retired in January 2000. In 1997, the Group started the fire prevention and fighting systems installation project for Fuzhou Changle International Airport (福州長樂國際機場) and was granted the status of an "excellent construction servicing unit" (福州長樂機場工程建設優質服務單位) by the Fuzhou Municipal People's Government (福州市人民政府) in June

## GENERAL OVERVIEW OF THE GROUP

1998. On 8th May, 1997, the registered capital of Fuzhou Wanyou Fire Prevention and Fighting Equipment Industrial and Trading Company Limited (福州萬友消防設備工貿有限公司) was increased to RMB10,000,000, contributed by the existing shareholders in proportion to their shareholdings. On 4th June, 1997, Fuzhou Wanyou Fire Prevention and Fighting Equipment Industrial and Trading Company Limited (福州萬友消防設備工貿有限公司) changed its name to Fuzhou Wanyou Enterprises Group Limited (福州萬友企業集團有限公司). On 3rd January, 1998, the registered capital of Fuzhou Wanyou Enterprises Group Limited (福州萬友企業集團有限公司) was increased by an additional sum of RMB500,000, wholly paid by Mr. Jiang Xiong, to RMB10,500,000. After the increase in registered capital, Mr. Jiang Shi Kai and Mr. Jiang Qing transferred RMB105,000 (representing 1% of the registered capital) and RMB4,830,000 (representing 46% of the registered capital), respectively of the registered capital of Fuzhou Wanyou Enterprises Group Limited (福州萬友企業集團有限公司) at cost to Mr. Jiang Xiong.

In 1998, the Group expanded rapidly on the supply and installation of fire prevention and fighting systems. In February 1998, the Group obtained the permit for the production of “fire-fighting gear control equipment” (消防聯動控制櫃). In July 1998, the Group was awarded “1994-1997 Fujian Province Outstanding Patent Enterprise (1994-1997年福建省專利優秀企業)” by Fujian Province Science and Technology Committee (福建省科學技術委員會) and Fujian Patent Administration Bureau (福建省專利管理局). In November 1998, the Group’s “fire prevention and fighting system installation permit” was upgraded to Class 1 temporary certificate (自動消防系統工程施工認可証暫定一類) and the Group was also granted the status of “High New Technology Enterprise (高新技術企業)” by Fujian Province Science and Technology Committee (福建省科學技術委員會). On 9th December, 1998, Fuzhou Wanyou Enterprises Group Limited (福州萬友企業集團有限公司) changed its name to Fujian Wanyou Enterprises Group Limited (福建萬友企業集團有限公司).

Apart from the emergency lighting system, in May 1999, the Group developed an interactive fire prevention and fighting control facility (消防聯動控制設備), which is the control unit of a fire alarm system used as a data processing and signal control device to issue an alarm signal in the event of a fire. Moreover, the Group was granted the ISO9002 certification for its production and servicing of a series of fire prevention and fighting products by China Certification Centre of Light Industry Quality (中國輕工質量認證中心). In addition, some of the Group’s fire prevention and fighting products were also granted the use of “fire product safety” certification mark by CCCFP in December 1999. In June 2000, the Group’s “fire prevention and fighting system installation permit” was upgraded to Class I Certificate (自動消防系統工程施工認可証一類).

On 16th January, 2000, Mr. Jiang Shi Kai transferred his remaining 1% equity interest in Fujian Wanyou Enterprises Group Limited (福建萬友企業集團有限公司) to Mr. Chen Shu Quan, a Director, and two independent third parties, of whom each of the three parties then held 0.6%, 0.2% and 0.2% equity interest in Fujian Wanyou Enterprises Group Limited (福建萬友企業集團有限公司), respectively. On 16th August, 2001, each of Mr. Chen Shu Quan and the two independent third parties transferred all of their equity interests in Fujian Wanyou Enterprises Group Limited (福建萬友企業集團有限公司), totalling 1% to Mr. Jiang Qing at an aggregate consideration of RMB250,000.

In November 2001, Mr. Jiang Qing transferred his entire 3% equity interests in Fujian Wanyou Enterprises Group Limited (福建萬友企業集團有限公司) to Wang Sing, a wholly owned subsidiary of the Company, at a consideration of HK\$1,200,000 as part of the Reorganisation, the details of which are set out in the paragraph headed “Corporate reorganisation” in the section headed “Further information about the Company” in Appendix IV to this prospectus. In the same month, Mr. Jiang Xiong also transferred his 97% equity interest in Fujian Wanyou Enterprises Group Limited (福建萬友企業集團有限公司) to Wang Sing at a consideration of HK\$38,800,000 in accordance with the Reorganisation.



## GENERAL OVERVIEW OF THE GROUP

Pursuant to an approval document dated 14th December, 2001 issued by Foreign Trade Economic Cooperation Committee of Fujian Province (福建省對外經濟貿易委員會), Fujian Wanyou Enterprises Group Limited (福建萬友企業集團有限公司) has obtained the status of a wholly foreign owned enterprise with a registered capital of HK\$10,500,000 (increased from the original RMB10,500,000). Fujian Wanyou Enterprises Group Limited (福建萬友企業集團有限公司) changed its name to Fujian Wanyou on 17 December, 2001.

Wanyou Engineering was established in the PRC on 23rd December, 1996 through its predecessor, Fuzhou Honghui Economic and Trade Company Limited (福州鴻輝經貿有限公司), a company principally engaged in the business of the manufacturing and sales of electronic parts and the Group was one of its customers. Fuzhou Honghui Economic and Trade Company Limited (福州鴻輝經貿有限公司) was first established with a registered capital of RMB1,000,000 by three shareholders, all of which are independent of the Group's executive Directors, chief executives and their associates. However, under the management of the then shareholders, the business was not profitable and showed no signs of recovery. Being one of the customers of Fuzhou Honghui Economic and Trade Company Limited (福州鴻輝經貿有限公司), Fujian Wanyou was aware of its situation and envisaged that there would be benefits for Fujian Wanyou if Fujian Wanyou became its controlling shareholder. The Group considered that the electronic parts produced by Fuzhou Honghui Economic and Trade Company Limited (福州鴻輝經貿有限公司) could be used as raw materials for the production of fire prevention and fighting products of the Group. Accordingly, it would provide a steady supply of quality components and lower the cost of production.

In April 1997, the Group acquired a 80% equity interest in Fuzhou Honghui Economic and Trade Company Limited (福州鴻輝經貿有限公司) at a consideration of RMB800,000. After the acquisition, the Group realised that the business of Fuzhou Honghui Economic and Trade Company Limited (福州鴻輝經貿有限公司) did not significantly reduce the cost of production and decided to reposition it for fire prevention and fighting system installation instead.

In September 1998, in an attempt to expand the fire prevention and fighting systems installation business, the Group further acquired the remaining 20% equity interest in Fuzhou Honghui Economic and Trade Company Limited (福州鴻輝經貿有限公司) at a consideration of RMB200,000 and changed its name to Fuzhou Wanyou Fire Service Engineering Company Ltd. (福州萬友消防工程有限公司). In September 1998, the registered capital was increased by an additional sum of RMB4,063,600 to RMB5,063,600. Among the RMB4,063,600 increase in registered capital, RMB2,484,500 was paid up by the Group and the remaining RMB1,579,100 representing approximately 31.19% of the enlarged share capital was paid up by Fujian Wanan. Fujian Wanan was then held as to 77% by Mr. Jiang Xiong, 3% by Mr. Jiang Qing and 20% by Mr. Liang Xun Lin, Mr. Jiang Xiong's father-in-law. Fujian Wanan was engaged in the manufacturing of computer parts. Save for the holding of 31.19% equity interest in Wanyou Engineering from September 1998 to March 2001, Fujian Wanan has had no material business. The present director of Fujian Wanan confirms that the company is currently dormant and its existing shareholders are independent of the Group's directors, chief executives or their associates. Pursuant to the increase of registered capital as stated above, the equity interest of the Group in Fuzhou Wanyou Fire Service Engineering Company Ltd. (福州萬友消防工程有限公司) was decreased to approximately 68.81%.

The Group began to use Fuzhou Wanyou Fire Service Engineering Company Ltd. (福州萬友消防工程有限公司) as the flagship on the provision of fire prevention and fighting systems installation. In April 2000, the name of Fuzhou Wanyou Fire Service Engineering Company Ltd. (福州萬友消防工程有限公司) was changed to Wanyou Engineering. In June 2000, Wanyou Engineering was granted another "fire prevention and fighting system permit" Class I Certificate

## GENERAL OVERVIEW OF THE GROUP

which was replaced by Class I Certificate for contractors of professional fire prevention and fighting systems installation (消防設施工程專業承包一級資質證書) in June 2002. In March 2001, Fujian Wanan transferred the equity interest of 31.19% in Wanyou Engineering at a consideration of RMB1,579,100 to Mr. Jiang Qing. The transfer represented a reward granted to Mr. Jiang Qing since the consideration was at par of the registered capital. At the same time, the registered capital of Wanyou Engineering was also increased by an additional of RMB2,000,000 to RMB7,063,600, which was taken up by Fujian Wanyou. After the increase in registered capital, the shareholdings of Fujian Wanyou and Mr. Jiang Qing in Wanyou Engineering were approximately 77.64% and approximately 22.36%, respectively.

In order to prepare the Group for listing, in March 2001, since Mr. Jiang Qing decided not to participate in the reorganisation of the Group, he then disposed of all his equity interest in Wanyou Engineering (ie. approximately 21.36% equity interest in Wanyou Engineering) to the Group at a consideration of RMB18,000,000, which was arrived at arm's length negotiation and represented 6 times price-earning multiple based on the estimated profit before taxation of approximately RMB15 million of Wanyou Engineering for the year ended 31st December, 2001 and the remaining 1% equity interest was transferred to an independent third party, Ms. Liu Mei Jin, at a consideration of RMB70,600 which was approximately equivalent to the 1% registered capital of Wanyou Engineering.

The Directors considered that Ms. Liu Mei Jin has substantial relationship in governmental and commercial areas and expected that such relationship will be able to assist the Group in terms of business development and public relations. Owing to such considerations, Mr. Jiang Qing, at the request of Mr. Jiang Xiong, disposed of his 1% equity interest in Wanyou Engineering to Ms. Liu Mei Jin at par, a lower consideration than that he disposed of the 21.36% equity interest in Wanyou Engineering to Fujian Wanyou. In addition, the transfer of 1% registered capital to the independent third party serves the purpose of satisfying the requirement of having at least two shareholders in respect of registration as a limited liability company in the PRC.

US Wanyou was incorporated on 5th March, 2002 and has not engaged in any significant business since incorporation. The Directors intend to position US Wanyou as the Group's gateway to the US market which conducts research and development and sales and marketing activities in the US.

In March 2001, Fujian Wanyou was approved as an authorised maintenance services provider of fire prevention and fighting systems by the Fujian Province General Bureau of Fire Services (福建省公安消防總隊). As the Group did not commence the Maintenance Services until June 2001, the turnover before the provision of sales tax generated from such business only amounted to approximately RMB2.6 million calculated up to 31st December, 2001. However, the Directors believe that the turnover generated by Maintenance Services will increase substantially in the coming years given the lack of competition and the tightening of the enforcement of fire prevention and fighting laws and regulations.

Wang Sing was incorporated on 12th October, 2000 and has been wholly-owned by Mr. Jiang Xiong since 16th October, 2001. Being attracted by the Group's significant growth and future development potential, Cantus, YMW and Morita, pursuant to subscription agreements dated 27th February, 2002 with Wang Sing and Mr. Jiang Xiong, subscribed for 10%, 2.19% and 1.46% of the equity interest in Wang Sing at a consideration of approximately HK\$40,000,000, HK\$8,745,900 and HK\$5,830,600 respectively. Upon completion of the Reorganisation and prior to the Placing as described in Appendix IV to this prospectus, Cantus, YMW and Morita are interested in 10%, 2.19% and 1.46% of the issued share capital of the Company. For details of these investors, please refer to the paragraph headed "Strategic Investors" in this section.

# GENERAL OVERVIEW OF THE GROUP

## Permits/Approvals obtained during the Track Record Period

**Table : Systems applicable to the products of the Company**

System	System of Production Permits	System of Fire Engine Catalogue	System of Mandatory Testing	System of Conformity of Product Quality
<b>Product</b>				
XYD emergency lighting	2 April 1995	N/A	N/A	N/A
XG fire fighting automatic broadcast system	13th May, 1999	N/A	N/A	N/A
XL interactive fire prevention and fighting control system	9th February, 1998	N/A	N/A	N/A
JTW-SD-WA103 spot size fire detector for environment with fixed range of temperature	N/A	N/A	N/A	8th December, 1999
JB-QB-WA3100 fire alarm monitor	N/A	N/A	N/A	8th December, 1999
JTY-LZ-WA100 spot size ion smoke sensing fire detector	N/A	N/A	N/A	8th December, 1999
JB-TB-ZH1010 general fire alarm monitor	N/A	N/A	N/A	20th December, 2000

## Year ended 31st December, 2000

### *Business development*

During the year, the Group was one of the parties which participated in the drafting and formulation of the national standard of fire emergency luminaries by the invitation of National Quality and Technology Supervision Bureau (國家質量技術監督局).

In April 2000, the Group was awarded Prize of Excellency at the 15th anniversary of Patent Registration in China (中國專利十五年成就展優秀項目) for its emergency lighting products and fire prevention ballast (防火鎮流器) granted by SIPO. In June 2000, the Group received the award of “AAA Credit Enterprise” (AAA級信用企業) from China Agricultural Bank Fujian Provincial Branch (中國農業銀行福建省分行). In June 2000, the “fire prevention and fighting system installation permit” was upgraded to Class 1 Certificate (自動消防系統工程施工認可証一類).

# GENERAL OVERVIEW OF THE GROUP

## *Sales and marketing*

During the year ended 31st December, 2000, the Group participated in various trade shows and forums to promote the “Wanyou” (萬友) brandname and its products, including the Nanjing Four New Fire Prevention and Fighting Expo (南京四新消防展覽會), Beijing Safety and Fire Prevention Expo (北京安全防火展覽會) and Guangzhou International Fire Prevention and Fighting Expo (廣州國際消防展覽會). The Group also advertised its products in fire prevention and fighting equipment magazines and journals, such as “Fire Services Education” (“消防教育通訊”) and “Fire Prevention Technique and Products Information” (“消防技術與產品信息”).

Apart from the market in Fujian Province, the Group’s product also covered different parts of the PRC, which mainly include Beijing, Shanghai and Jiangsu. The Group had completed 11 fire services installation projects in Fujian Province including Chingkou Vehicle City of Dongnan Automobiles (東南汽車城). The turnover generated from the sales of fire prevention and fighting equipment and the fire prevention and fighting systems installation projects before the provision of sales tax in 2000 were approximately RMB72,475,000 and approximately RMB13,572,000 respectively.

## *Product development*

In 2000, the Group enhanced the functions of 5 models on emergency lighting systems.

## *Development of human resources*

As at 31st December, 2000, the Group employed a total of 317 employees and the following table categorises these employees by their duties:

	<b>Total</b>
Sales and marketing	69
Fire services installation (including maintenance services)	14
Production (including quality control and assurance)	204
Research and development	6
Finance and administration	24
	<hr/>
	317
	<hr/> <hr/>

## **Year ended 31st December, 2001**

### *Business development*

In March 2001, the Group was awarded Contractual Responsibility and Trust-worthiness Safe-guarded Entity (重合同守信用單位) by Fujian Province Industries and Commerce Administration Bureau (福建省工商行政管理局) after demonstrating its successful business operation. In addition, the Group continued to receive the status of “AAA Credit Enterprise” (AAA信用企業) from China Agricultural Bank Fujian Provincial Branch (中國農業銀行福建省分行企業資信評審委員會) in April 2001. In December 2001, Fujian Wanyou Enterprises Group Limited (福建萬友企業集團有限公司) changed its name to Fujian Wanyou and became a Wholly Foreign Owned Enterprise (“WFOE”) established in the PRC. Moreover, the head office of SAIC (國家工商行政管理總局) awarded the Group as one of the first batch “Contractual Responsibility and Trust-worthiness Safe-guarded Entity” (“重合同守信用單位”) amongst 520 enterprises on a national basis.

## GENERAL OVERVIEW OF THE GROUP

In February 2001, Wanyou Engineering obtained ISO9002 certification on its installation, construction and adjustment on the fire prevention and fighting system from China Certification Centre of Light Industry Quality (中國輕工質量認證中心).

On 28th March, 2001, Mr. Jiang Qing transferred his 21.36% equity interest in Wanyou Engineering to Fujian Wanyou at a consideration of RMB18,000,000 and on 18th November, 2001, he transferred his 3% equity interest in Fujian Wanyou to the Group at a consideration of HK\$1,200,000, in accordance with the Reorganisation, the details of which are set out in the paragraph headed “Corporate reorganisation” in the section headed “Further information about the Company” in Appendix IV to this prospectus.

### *Sales and marketing*

During the year, the Group’s market covered many different cities and provinces in the PRC, namely, Shanghai, Beijing, Jiangxi, Shangdong, Jiangsu, Guangdong, Sichuan, Henan, Hebei, Yunan, Liaoning and Guangxi. Apart from the sales of fire prevention and fighting equipment, the Group also completed 19 fire prevention and fighting systems installation projects in the Fujian Province including Fuzhou Fire Services Control Centre (福州消防指揮中心). The turnover generated from the sales of fire prevention and fighting equipment and the fire prevention and fighting systems installation projects before the provision of sales tax were approximately RMB145,587,000 and approximately RMB50,075,000 respectively.

The Group also participated in various conferences and exhibitions in various cities in the PRC, such as Ninxia, Changsha, Zhengzhou and Chongqing, to further promote the Group’s products to other provinces. In October 2001, the Group’s brand name “Wanyou” (“萬友”) was awarded as one of the 80 most outstanding brandnames in Fuzhou for the year 2000. The award was given by Fuzhou Municipal People’s Government and the Group is the only enterprise engaged in the fire prevention and fighting business receiving such award.

### *Deployment of human resources*

As at 31st December, 2001, the Group employed a total of 566 employees and the following table categorises these employees by their duties:

	<b>Total</b>
Sales and marketing	78
Fire services installation (including maintenance services)	18
Production (including quality control and assurance)	433
Research and development	12
Finance and administration	25
	<hr/>
Total	<u>566</u>

# GENERAL OVERVIEW OF THE GROUP

## Period from 1st January, 2002 to the Latest Practicable Date

### *Business development*

In June 2002, Wanyou Engineering obtained Class I Certificate for contractors of professional fire prevention and fighting systems installation (消防設施工程專業承包一級資質證書) from 中華人民共和國建設部 which replaced the “fire prevention and fighting system installation permit” Class I Certificate.

### *Sales and marketing*

In February 2002, the Group set up a new branch office in Jiangsu Province to strengthen its sales channel. In addition, the Group was awarded 6 new fire prevention and fighting systems installation projects in Fujian Province. US Wanyou was incorporated on 5th March, 2002 and has not engaged in any significant business since incorporation. The Directors intend to use US Wanyou as the Group's arm in the US to assist in research and development and sales and marketing activities in the US.

### *Product development*

With the intention to receive wider recognition of its products, the Group has obtained CE certificates (products quality conforms to European Standard) for its emergency lighting system in April 2002. In May 2002, the emergency lighting system of the Group was tested as being compliant with the UL standard (products quality conforming to US Standard) and the certificate was then awarded.

### *Funding arrangements*

On 1st March, 2002, Wang Sing, a wholly-owned subsidiary of the Company, issued 1,365 ordinary shares to raise approximately HK\$54,600,000 in aggregate. The details of the arrangements are as follows:

Name of investor	No. of Shares acquired	Total consideration HK\$	
Cantus	1,000	US\$5,128,205	40,000,000
YMW	219	¥150,000,000	8,745,900
Morita	146	¥100,000,000	5,830,600
	<u>1,365</u>		<u>54,576,500</u>

Upon completion of the above issues of new shares, Cantus, YMW and Morita held 10 per cent., 2.19 per cent. and 1.46 per cent. of equity interest in the capital of Wang Sing respectively. As a result, the equity interest of Jiang Xiong in Wang Sing reduced to approximately 86.35 per cent.

# GENERAL OVERVIEW OF THE GROUP

## *Deployment of human resources*

As at 31st July, 2002, the Group employed a total of 529 employees and the following table categorises these employees by their duties:

	<b>Total</b>
Sales and marketing	93
Fire services installation (including maintenance services)	21
Production (including quality control and assurance)	369
Research and development	12
Finance and administration	34
	34
<b>Total</b>	<b>529</b>

## **DESCRIPTION OF BUSINESS**

The Group is one of the few integrated fire prevention and fighting system designer, manufacturer and installation services providers in the PRC. The Group commenced the manufacturing of fire emergency lighting in 1995 and gradually developed into a manufacturing powerhouse producing integrated fire prevention and fighting systems comprising of fire alarm systems, emergency lightings and smoke detectors. Approved by the fire service department of Fujian Province, the Group commenced the fire prevention and fighting systems installation service in 1996. The Group currently holds a certificate which enables it to handle Installation Services for all kinds of construction projects. In March 2001, the Group was authorised by Fujian Province General Bureau of Fire Services (福建省公安消防總隊) to undertake annual inspection and maintenance of all kinds of fire preventing and fighting systems. Such qualification is applicable nationwide in the PRC.

For the two years ended 31st December, 2001 and the seven months ended 31st July, 2002, the Group's revenues were generated from Product Sales, Installation Services and Maintenance Services in the proportion shown as follows:

**For year ended 31st December, 2000**

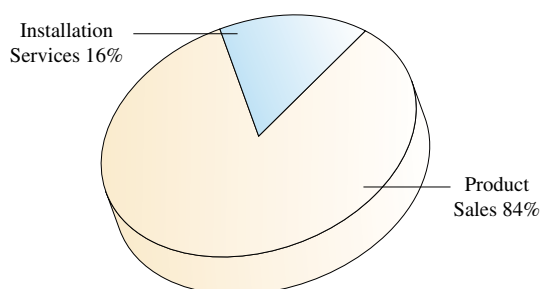

**For year ended 31st December, 2001**

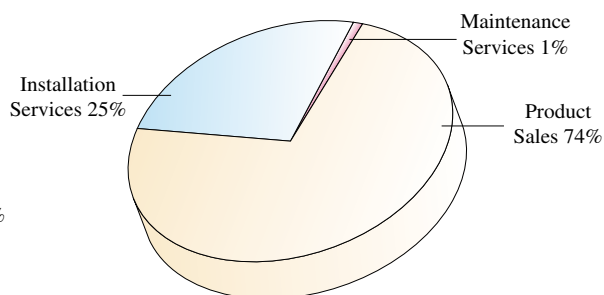

# GENERAL OVERVIEW OF THE GROUP

For Seven months ended 31st July, 2002

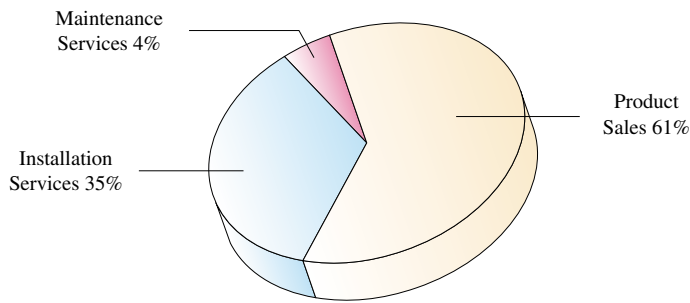

## BUSINESS MODEL OF THE GROUP

The Group's business model, through the provision of Product Sales, Installation Services and Maintenance Services, is to establish itself as a total solution provider of fire prevention and fighting systems that create synergy. The Directors consider that the provision of Installation Services and Maintenance Services enable the Group to accumulate information and learn about the market demand, which in turn complement the development of the products by the Group. On the other hand, the design and manufacturing capability of the Group enables it to have a competitive advantage in the Installation Services and Maintenance Services. Under certain circumstances, the Group undertakes the design and manufacturing of fire prevention and fighting system under its own brandname and supply it to other installation services providers mainly outside Fujian Province. With such business model, the Group's products are widespread throughout the PRC while its reputation and recognition builds up gradually. The diagram below illustrates the business model of the Group.

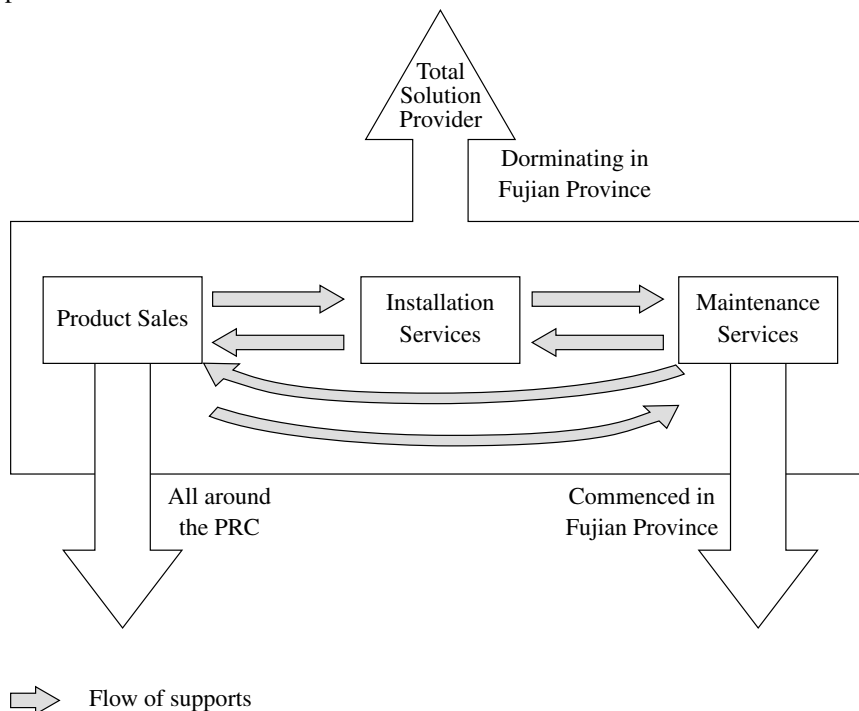



# GENERAL OVERVIEW OF THE GROUP

## I. Product Sales

### Products

Currently, the equipment of fire prevention and fighting systems developed and produced by the Group principally comprises the follows:

- (i) Fire alarm systems mainly consist of equipment as illustrated below:

#### Multi-CPU distribution intellectualized large-scale fire prevention and fighting management system

The core concept of a fire prevention and fighting system is to sense the occurrence of a fire in a timely manner and to send out an alarm or to coordinate interaction in accordance with the grading of the fire. Therefore, an automated fire prevention and fighting system comprises sensors, execution units, control units and control networks. The fire alarm control units form a network with a vast number of detectors, input and output modules, manual devices, display units and transmission devices which are scattered across the location. It strives to give out alarm signals, output control signals and coordinate interaction with relevant equipment in a reliable and timely manner in case of a fire in order to stop the fire from spreading.

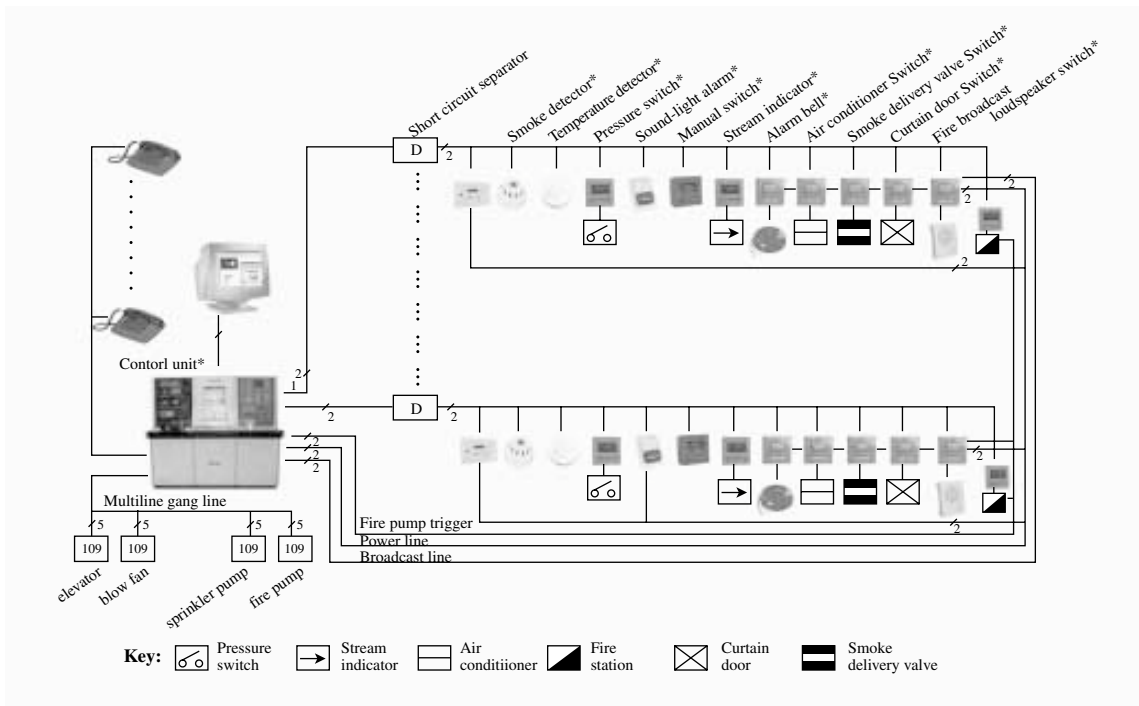

\* items produced by the Group

## GENERAL OVERVIEW OF THE GROUP

### *Description of operation*

The smoke detector and the temperature detector constantly pass the data on temperature changes and smoke density to the control unit, a data processing and signal control device made up of a personal computer or a mini-computer. In case of a fire, the control unit will issue an alarm signal, based on the data obtained from the smoke detector and temperature detector of the respective area. After receiving the alarm signal, the operator in the operating control station will then notify the fire station. The operator will also trigger the multiline gang line and switch on various fire extinguishing devices, such as blow fan, sprinkler pump and fire pump.

#### (ii) Emergency lighting systems



Emergency lighting system provides illumination that requires no external energy source and is normally activated when an accident or a fire hazard occurs.

The installation of fire alarm system and emergency lighting system are mandatory for all buildings according to the Fire Service Law of the PRC (中華人民共和國消防法).

## GENERAL OVERVIEW OF THE GROUP

According to the Fire Service Regulations (中國消防條例) and the Fire Service Law in the PRC (中華人民共和國消防法), any fire prevention and fighting products distributed in the PRC must comply with the market access requirement (準入制度). The market access requirement is comprised of four systems of administration, namely, the system of fire engine catalogue (消防車目錄制度), the system of production permits (生產許可證制度), the system of conformity of product quality (認證制度) and the system of mandatory testing (強制檢驗制度). Fire prevention and fighting products is permitted to be sold in the PRC if it meets any one of the four criteria:

- (a) obtain the Certificate of Conformity of Product Quality (產品質量認證證書); or
- (b) obtain the national production permit for industrial products (全國工業產品生產許可證證書); or
- (c) listed on the national catalogues of production enterprises and products of vehicles, civilian refitted vehicles and motorcycles published by the State Machinery Industry Bureau and the Ministry of Public Security; or
- (d) pass the “model” tests of the PRC Quality Control Testing Centres for fire prevention and fighting products.

Since the Group obtained the national production permits in the years 1995, 1998 and 1999 and the certificates of conformity of product quality in 1999 and 2000, its products can be sold throughout the PRC.

Prior to the production and sales of each product, the Group had obtained the relevant required certificate and/or license.

### *Pricing policy*

The Group generally sets the market price of its products based on market condition. Management and sales managers monitor prices of the products constantly. Having considered factors such as price of major competitors, seasonal factor and amount of orders, the management determine pricing guidelines for the Group's products. The pricing guideline will then be passed to the sales department for determining selling price. Any discount must be approved by the management in writing before confirming an order. The Directors consider that during the Group's Track Record Period, its products price varied in a narrow range and there were no significant price fluctuation.

### *Sales and marketing*

The turnover of the Group, net of sales tax for the two years ended 31st December, 2001 and for the seven months ended 31st July, 2002 were approximately RMB84 million, RMB194 million and RMB148 million respectively and the profit before minority interests of the Group amounted to RMB44.5 million, RMB98.8 million and RMB74.7 million respectively. The Group currently has 16 branch offices located in different regions in the PRC. In addition, the Group also sells its products through 17 distributors.

## GENERAL OVERVIEW OF THE GROUP

The map below indicates the location of the Group's branch offices and distributors in the PRC:

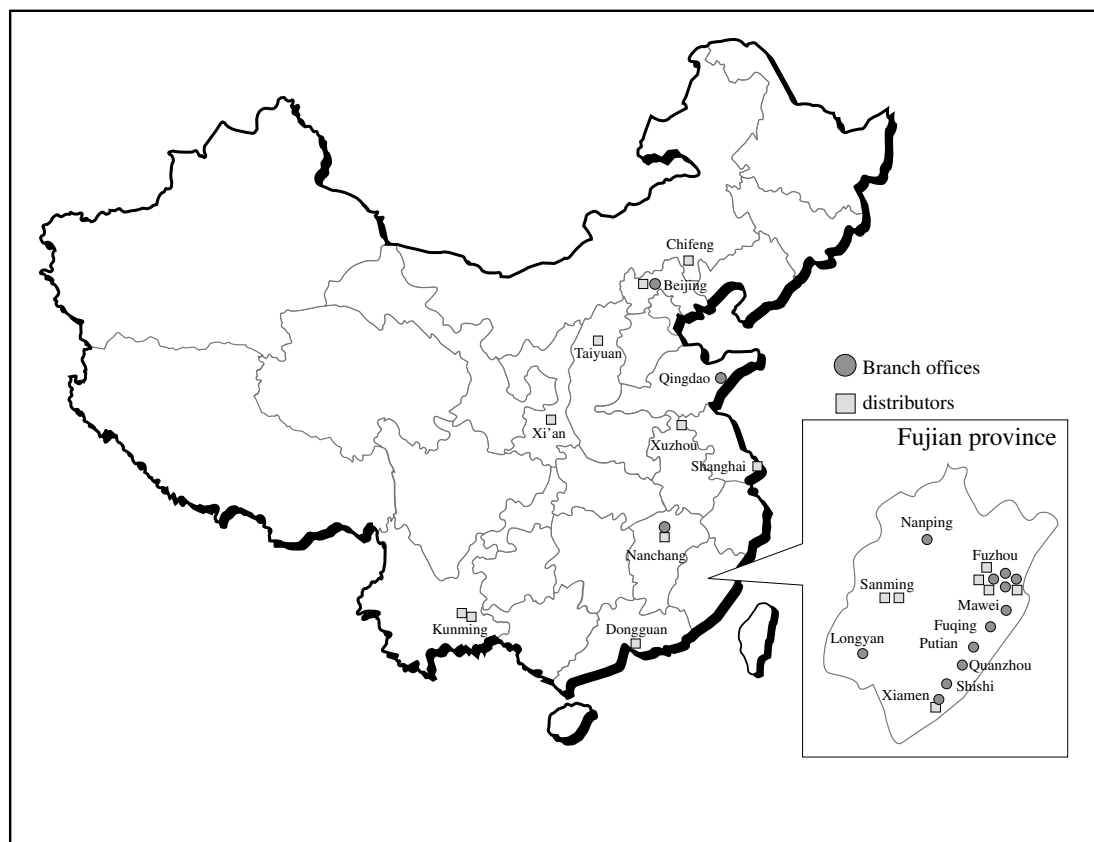

The Group's overall sales and marketing strategies are formulated by sales executives in conjunction with its management at the the head office in Fuzhou. The individual branch offices are responsible for (i) the promotion, marketing and sales of the Group's products; (ii) the provision of technical support services to the Group's customers in their respective areas; and (iii) the supervision of the sales activities of the distributors in their respective areas. The head office provides pricing guidelines of the Group's products to its branch offices from time to time, and the branch offices offer the Group's products at such set prices to the customers. Any discount to such set price requires written approval by a Director. The sales representatives of each branch office are responsible for gathering orders from customers and passing them to the head office for processing. The sales representatives have regular meeting with the distributors to discuss the feedback of end-users on the Group's products. In addition, the sales representatives identify decoration companies and property sub-contractors and visit them to promote the Group's products.

## GENERAL OVERVIEW OF THE GROUP

Apart from selling the products through the Group's own sales channel, the Group has also entered into non-exclusive distribution agreements with 17 distributors. The distributors are mainly decoration companies and fire prevention and fighting product suppliers located in various cities and provinces in the PRC, namely, Fujian, Yunan, Guangdong, Henan, Jiangxi, Shanxi, Beijing and Shanghai. The distribution agreements usually have a term of one year (such term will be automatically extended if there is no dispute between the parties) pursuant to which the distributors are generally responsible for marketing and promoting the Group's products. The Group and the respective distributors will usually agree on an annual sales target and the Group sells its products to them at a discount recommended by the Group. The discounts offered to distributors range from 25% to 30% depending on their relationship with the Group. For the two years ended 31st December, 2001 and for the seven months ended 31st July, 2002, the Group has maintained an average length of business relationship of one to four years with these distributors. Sales representatives of the Group are assigned to look after the business of the distributors and monitor the sales activities of their respective assigned distributors. For the two years ended 31st December, 2001 and for the seven months ended 31st July, 2002 distributors' sales accounted for 11%, 25% and 45%, respectively of the total Product Sales of the Group.

In general, the Group's Product Sales customers settle payment by cash on delivery of products. However, the Directors may grant credit terms ranging from 30 days to 90 days to customers on a case by case basis depending on an assessment of their length of business relationship, credit history and financial reliability. When a sales order is received from a new customer, credit terms are determined by a sales manager and then reported to a Director for approval. When a sales order is received from an existing customer, credit terms are determined in accordance with the previous ones. The credit terms for each customer have to be reviewed and approved by the management on an annual basis. To improve collection of accounts receivable, monthly aging analysis report on accounts receivable and exceptional report of overdue accounts receivable are prepared by the accounting department and reviewed by the management. The relevant sales managers then follow up the collection or the overdue accounts receivable from the respective customers and report to the financial controller on the process of collection. Write-offs of bad debts or provisions for doubtful debts are normally proposed by the financial controller and approved by the board of Directors. The Group maintains a good relationship with its customers and does not have any debt collection problem since the commencement of operation. All of the Group's sales are denominated in Renminbi and the Group has full discretion in determining the prices of its products without any legal or regulatory limitation on pricing. Nevertheless, the Directors consider the pricing of the Group's products are in compliance with the government's requirement as the Group was awarded "Price & Measure Trustworthy Enterprise" ("物價、計量信得過企業") by the Price Administration Bureau of Taijiang District of Fuzhou City (福州市台江區物價管理局) in March 1998.

For Product Sales, it is the Group's policy that 50% of the general provision for doubtful debts are made for debts aged over 90 days, excluding specific debtors with acceptable credit worthiness and 100% for debts aged over one year. The aging analysis of the outstanding accounts receivable for the seven months ended 31st July, 2002 after accounted for the provisions and subsequent settlement up to 31st August, 2002 is set out as follows:

	<i>RMB'000</i>
Not exceeding 90 days	18,823
More than 90 days but not exceeding one year	18

## GENERAL OVERVIEW OF THE GROUP

The management regularly reviews the aging analysis and settlement records to determine whether specific provision is necessary. For the two years ended 31st December, 2001 and for the seven months ended 31st July, 2002, specific provision for doubtful debts amounting to approximately RMB675,000, RMB185,000 and RMB168,000 respectively were made.

For each of the two years ended 31st December, 2001 and for the seven months ended 31st July, 2002, the Group's sales of products to its five largest customers together accounted for approximately 23.9 per cent., 26.2 per cent. and 33.0 per cent. of the Group's total sales respectively and sales of products to its largest customer alone accounted for approximately 9.5 per cent., 8.1 per cent. and 10.7 per cent. of the Group's total sales respectively. None of the Directors, chief executives and Substantial Shareholder or Initial Management Shareholder of the Group or their respective associates and shareholders who own more than 5 per cent. of the issued share capital of the Company has any interest in any of the five largest customers of the Group for each of the two years ended 31st December, 2001 and for the seven months ended 31st July, 2002. For the two years ended 31st December, 2001 and for the seven months ended 31st July, 2002, the Group has maintained over 2 years, over 3 years and over 4 years of business relationship, respectively with the five largest customers. These customers are mainly construction sub-contractors, fire prevention and fighting systems installation contractors and trading companies supplying fire prevention and fighting equipment and accessories, fire retardant materials and decoration materials.

Apart from sales to independent customers, Fujian Wanyou also sells its product to its 99% owned subsidiary, Wanyou Engineering. During the two years ended 31st December, 2001 and for the seven months ended 31st July, 2002, the sales to Wanyou Engineering was approximately RMB1.6 million, approximately RMB10 million and RMB13 million, respectively representing approximately 2%, 7% and 12%, respectively of the total Product Sales. The sales comprised fire emergency lighting system and fire alarm system which were offered on the same commercial terms as to independent customers. The products which Fujian Wanyou sold to Wanyou Engineering were entirely utilised in the Installation Services of Wanyou Engineering in the past and it is the Group's policy to adopt the same in the future. As most of Fujian Wanyou's major independent customers are construction sub-contractors, fire prevention and fighting systems installation contractors and trading companies supplying fire prevention and fighting equipment and accessories, fire retardant materials and decoration materials, the Group's products are often ordered in integrated fire fighting and prevention system comprising fire alarm system, emergency lighting and smoke detectors. On some occasions, the Group provides system design services and installation advice to its customers. The Group has not charged fee regarding such kind of value added services and does not intend to charge fee in the future. The Directors believe that such capability of the Group has assisted the sales of the Group's products. The Directors believe that one of the effective marketing strategies can be achieved through demonstration of the functionality of the products. Therefore, a retail outlet is set up in Fuzhou to promote the Group's products. In addition, the Group promotes its business through participation in trade shows and exhibitions. To increase the awareness of its products to customers, the Group also advertises its products in and issues press releases to business magazines and fire prevention technology journals. In addition, the Group also organises seminars to promote its products.

# GENERAL OVERVIEW OF THE GROUP

## *Production facility*

The Group retains its major production facility of a gross floor area of approximately 2,500 sq.m. in Fuzhou City, Fujian Province, the PRC. The existing production facility was relocated in July 2001 due to the Group's expansion. The production facility is in full operation and has about 369 employees, including management staff and technicians, for the production of equipment for the fire alarm system and the emergency lighting system. The Group has outsourced the manufacturing of components of the products to independent subcontractors located in the PRC. The production facility of the Group undertakes the assembly of different components, function testing and quality inspection of the finished products.

The production facility is currently operating 8 hours a day and 5 days a week. The capacity of the production facilities can be doubled if they are operating in two shifts of 8 hours each. As the Group has been keeping a satisfactory quality control system over its subcontractors, the Group will be able to out-source various production processes. The Directors believe that it is in the interest of the Company to keep manufacturing at a minimal scale by outsourcing production of certain parts of the Group's products, which can relieve the Group from additional management and inventory burdens.

## *Production process*

The following is the flow chart which describes the principal steps involved in the production processes of fire alarm system and emergency lighting system.

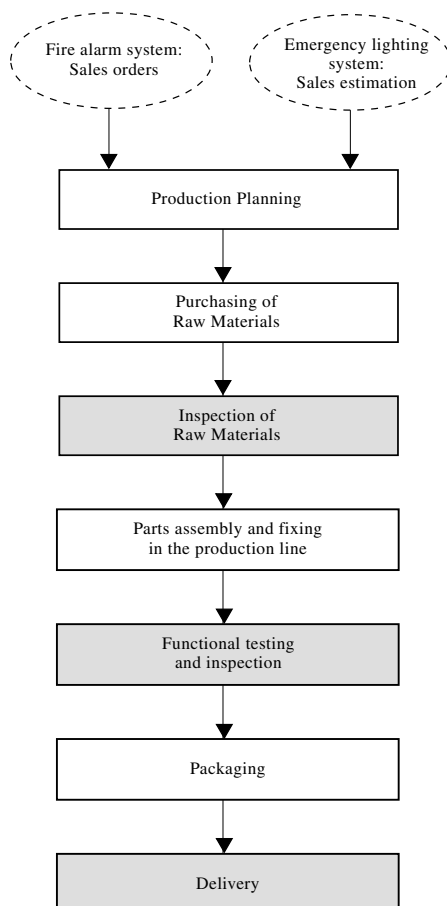

## GENERAL OVERVIEW OF THE GROUP

The Group formulates its production plan primarily according to sales order on equipment for fire alarm systems and sales estimates on equipment for emergency lighting systems. Since the commencement of operation, the Group has been able to impose a tight control on its inventory level whilst fulfilling the sales orders.

The production planning department works closely with the sales department and other sections of the production process. It estimates and monitors the required timing of production. After the production plan is formulated, the purchase department purchases the raw materials and accessories for production. Apart from purchasing the necessary materials, the Group normally sub-contracts the manufacturing of components and parts of its products (e.g. moulds, electric circuit boards) to those enterprises which specialised in the processing of electronic and mechanic parts. After receiving the design and materials from the Group, the sub-contractors return the semi-finished parts to the Group for quality inspection and final assembly. For the two years ended 31st December, 2001 and for the seven months ended 31st July, 2002, the Group engaged 8, 11 and 11 subcontractors, respectively. The production line of the Group assembles and fixes all raw materials and semi-finished parts. After further testing and inspection, the products are packaged and delivered to customers. The whole production process normally takes about 10 days for an emergency lighting system and 20 days for a fire alarm system to complete.

### *Purchase and procurement*

The Group purchases all the raw materials in the PRC. The raw materials are mainly electronic parts, batteries, semi-conductors and electrical equipment accessories. At present, the Group purchases most of its raw materials from a number of electrical equipment and accessories suppliers in the PRC. The Directors consider that the Group has a stable relationship with these suppliers and no difficulty has been encountered in the sourcing of raw materials in the past. As the raw materials required by the Group are not rare or difficult to source, the Directors do not anticipate any difficulty in the sourcing of raw materials for production in the foreseeable future.

The Group usually enters into purchase agreements with major raw material suppliers whereby the prices, quality and specification of the raw materials required are stated. The suppliers normally give 60 days to 90 days credit term to the Group and any outstanding amounts with the suppliers are cleared at the end of the year. Currently, the Group pays for its purchases according to credit terms and has never encountered any problem of settlement with the suppliers.

For each of the two years ended 31st December, 2001 and for the seven months ended 31st July, 2002, purchases from the five largest suppliers accounted for approximately 70%, 73% and 57% respectively and the largest supplier accounted for approximately 29%, 25% and 23% respectively of the Group's total purchases. None of the Directors, chief executives and Substantial Shareholder or Initial Management Shareholder of the Group or their respective associates and shareholders who own more than 5 per cent. of the issued share capital of the Company has any interest in any of the five largest suppliers of the Group. For the two years ended 31st December, 2001 and for the seven months ended 31st July, 2002, the Group has maintained over 2 years, over 3 years and over 4 years, respectively with the five largest suppliers. These suppliers are mainly companies distributing electronic parts, accessories, batteries, plastic moulds, cable wiring and communication equipment.



## GENERAL OVERVIEW OF THE GROUP

### *Quality control*

The Group has to keep a stringent standard for quality control, as the sales of fire prevention and fighting systems require Certificates of Conformity of Product Quality. In addition, the Directors believe that testing and quality control of the Group's products are important to its reputation and long-term business development. The Group was awarded the ISO9002 certificate in 1999 for its quality control procedures on its products. Such quality control procedures are implemented at three different stages: before the raw materials enter the production process, during the production process and when the finished products leave the production line.

When the raw materials arrive at the factory premises of the Group, they are examined for their quality to ensure that they meet the required standard. During the production process, quality control staff closely monitors and performs quality check in each production procedure specified by the quality control manual of the Group. After completion of the assembly of the products, they are required to pass several quality control points, such as aging, functionality and durability tests, according to their specific requirements.

In order to ensure the quality of processed parts and components, the Group's quality control department will carry out on site inspection of the processing enterprises and perform quality check on all the processed parts and components.

### *Inventory control*

The Group will decide the amount of raw materials to be ordered based on the market conditions of raw materials supplies, the time required for the ordering and delivery of raw materials and the demand of major customers. Designated officers are responsible for monitoring the usage and inventory level on a regular basis, in order to maintain appropriate inventory level for its operational needs. This close monitoring process avoids excessive inventories that may remain unused for a long period of time.

Inventories of the Group are stated at the lower of cost and net realisable value after making due allowance for any obsolete or slow-moving items. Cost of inventories is determined on a weighted average of cost basis. Net realisable value of inventories is based on estimated selling prices less any further cost expected to be incurred to disposal.

The Group will carry out inspection of inventories and stocktake on a semi-annual basis to examine their conditions. The Group's inventory provision policy is based on the aging of the actual obsolete inventory identified. If the inventory is obsolete, full provision will be made on the specific item. Inventory which does not have any movements for over one year will be considered as slow moving and an appropriate general provision will be considered accordingly. During the Track Record Period, no significant slow moving or obsolete inventory was identified, therefore no specific or general provision had been made.

### *Repair and maintenance*

All parts of the production facility are examined periodically and a detailed record of checking is kept for such production facilities. For each of the two years ended 31st December, 2001 and for the seven months ended 31st July, 2002, the repair and maintenance expenses of the Group were approximately RMB11,000, RMB26,000 and RMB12,000 respectively.

# GENERAL OVERVIEW OF THE GROUP

The Directors believe that all the Group's production facilities have been well maintained and there have been no suspension of the production lines ever since their commencement of operation.

## II. Installation Services

The Group is engaged in both the private and public sector fire prevention and fighting systems installation projects. Since the Group commenced its operation in the Installation Services, the Group has been awarded more than 77 projects. The breakdown of the Installation Services sales is set out as follows:

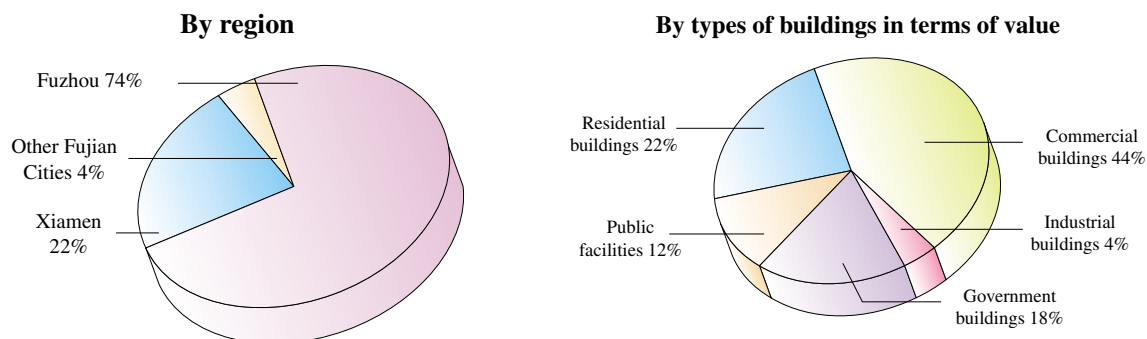

Contract amounts of the above mentioned projects range from RMB100,000 to RMB15 million. Set out below are the ten largest projects of the Group in terms of contract amount during the Track Record Period.

Project Name	Commencement date of work	Completion date/ Anticipated completion date	Contract value (note 1) RMB'000
- Zhongmin Da Sha (中閩大廈)	November 2001	November 2002	15,000
- Fuzhou Hua Yuan Tai (福州花園台)	January 2002	December 2003	9,000
- Xiamen Xiao Xiang Da Sha (廈門瀟湘大廈)	October 2001	October 2002	8,600
- Fujian Province Di Fang Shui Wu Ju Da Lou (福建省地方稅務局大樓)	January 2002	January 2003	8,000
- Mei Tan Da Sha (煤炭大廈)	November 2000	November 2001	6,325
- Fujian Province Land Administration Data Office (福建省土地管理檔案庫)	June 2002	June 2003	5,500
- Fuzhou Zhi Fu Da Sha (福州置福大廈)	August 2000	November 2001	5,059
- Wu Zhou Da Sha (五洲大廈)	September 1999	December 2000	4,470
- Ruan Jian Zhong Xin Gong Cheng (軟件中心工程)	December 2000	December 2001	4,037
- Hu Dong Da Sha (湖東大廈)	November 2000	November 2001	3,850

Note:

- The contract value represents the original contract value which is subject to variations agreed with the relevant developer and/or main contractor pursuant to the contract.

## GENERAL OVERVIEW OF THE GROUP

The Group's installation service projects can be divided into the following phases: tendering for projects, procurement of parts, project management and quality control. To ensure that consistent and acceptable installation standards are maintained, the Group has developed its own internal system and guidelines for preparing tenders, procuring parts, project management and quality control. The Group has completed all its fire prevention and fighting systems installation projects in accordance with the schedule agreed by the relevant parties.

### *Project tendering*

Contracts for both private and public sector fire prevention and fighting systems installation projects are normally awarded following a tendering process. Invitations to tender for public sector contracts are advertised in the government journal and the press. The Group has well-established relationships with a number of major property developers, construction groups and engineering consultants in Fujian Province, which enables it to receive invitations from them to bid for private sector fire prevention and fighting systems installation projects. At present, the Group performs all the fire prevention and fighting systems installation projects in the Fujian Province.

The tendering process begins with regular meetings between certain executive Directors as well as the general manager. The tendering team comprises 5 to 6 members, some of whom are engineers and experienced equipment merchandisers. Preparation work carried out by the tendering team involve obtaining and assessing information on the cost and supply of parts and labour and estimating the time required to complete the project. Tender drawings are also analysed to identify alternatives which may reduce project costs. Having assessed the alternatives and after reviewing the Group's projects on hand as well as its relative competitiveness in the relevant tender, the tendering team will then submit its proposition to such Directors who then decide on pricing strategy. The preparation of a cost estimate and the finalisation of a contract tender usually takes about two weeks.

### *Project management*

Upon acceptance of a tender, a project management team is formed. The project management team is comprised of up to 10 members depending on the contract value, the site area, the size and complexity of the relevant project. Team members include a project manager, engineers, technicians, purchasers, supervisors and foremen. The project management team is responsible for the execution of the installation work, including procurement of parts, deployment of financial and manpower resources to achieve timely completion of projects. The engineers, supervisors and foremen of the project management team are responsible for the on-site day-to-day progress of work and the project manager is in charge of the overall management of the project. Weekly meetings are held by the project management teams to review work-in-progress at all sites. Fire prevention and fighting systems installation projects typically require one to two years to complete.

In order to ensure timely completion of installation projects, the Group normally employs temporary workers to perform basic installation duties. The number of temporary workers employed depends on the size and value of projects. These temporary workers are paid on a daily basis and are employed on a project basis. The Directors believe that the employment of temporary workers can ensure the smooth operation of the installation project.

# GENERAL OVERVIEW OF THE GROUP

## *Procurement of parts*

A typical fire prevention and fighting system in relation to the Installation Services includes the follows:

- (i) fire alarm system;
- (ii) smoke prevention and exhaustion system;
- (iii) emergency lighting system;
- (iv) fire-fighting gear control system; and
- (v) fire suppression system;

For all the Installation Services projects undertaken by the Group, the Group designs tailor-made fire alarm systems and emergency lighting systems by making use of the products manufactured by the Group and the knowhow available to the Group.

The principal parts required for the fire suppression systems in respect of commercial and residential buildings are pipes and fittings, sprinkler equipment, fire hydrants and hose reels, pumps and motors, conduits and wirings, valves and gas cylinders and nozzles. Special requirements are imposed on industrial buildings according to the guidelines of the PRC Construction Design and Fire Protection Regulations (中華人民共和國建築設計防火規範). The principal parts are mainly sourced in the PRC. Over the years, the Group has built up good relationships with many suppliers and has not experienced any major difficulties in obtaining parts. Settlements with such suppliers are mainly made on a bi-monthly basis. For each of the two years ended 31st December, 2001 and for the seven months ended 31st July, 2002, the five largest suppliers of parts for the fire prevention and fighting systems installation projects accounted for approximately 70.99%, 74.50% and 56.78% respectively of the total purchases of the Group and the largest supplier of parts for the fire prevention and fighting systems installation projects accounted for approximately 34.03%, 55.06% and 23.07% respectively of the total purchases of the Group. The Directors presently do not anticipate any material adverse effect on the results of the Group arising from the loss of any supplier.

## *Quality control*

The Group places much emphasis on quality control over its installation work on site. Internal quality control procedures are set up for every installation project and quality control tests are applied during the installation process. Two main types of quality control tests are usually performed on an area-by-area basis:

- (i) hydraulic test – applied to fire hydrant / hose reel systems and automatic sprinkler systems to ensure that there is no leakage of water from the installation; and
- (ii) insulation test – applied to smoke or heat detectors and alarm systems to ensure that there is no short circuiting of electricity in the installation.

## GENERAL OVERVIEW OF THE GROUP

When the installation work is completed, an overall functional test is performed on the fire prevention and fighting system of the project to the satisfaction of the main contractor of the construction project and the developer. In addition, the installation work is subject to the final inspection by the Fire Services Department of the Ministry of Public Security which, after having tested the installation work, will issue a certificate stating that the fire prevention and fighting systems installation and equipment have been installed in accordance with the Fire Service Law of the PRC (中華人民共和國消防法) and the installation is in an efficient working order and satisfactory condition. The Group also provides one to two year maintenance period for its installation projects and an engineer is assigned to check the working condition of the completed installations on a quarterly basis.

### *Payment terms*

The Group usually bills the developer or the main contractor in accordance with the progress of a project on a monthly basis. A common practice of the construction industry in the PRC is that the developer would generally withhold a certain percentage of the contract sum (usually between 5% to 10%) from the main contractor as retention money which is intended to protect the developer from any deficiency caused by the main contractor. Same as the construction industry, such practice is also followed in fire prevention and fighting systems installation projects. A percentage of the contract sum is usually withheld by the developer or the main contractor as retention money and will generally be released 12 months following completion of the relevant project. In the cases of the Group, the percentage to be retained is specified in the contract and is usually between 1% to 5% of the contract value. During the Track Record Period, the Group has not experienced any material bad debts resulting from such payment practice.

### **III. Maintenance Services**

According to Regulations of the Supervision, Auditing and Administration of Fire Prevention and Fighting Systems Installation in Construction (建築工程消防監督審核管理規定), the owner of every building is required to enter into maintenance service contract with an authorised maintenance services provider who performs checking and maintenance services for the existing fire prevention and fighting systems in order to ensure normal operation of the systems. In March 2001, the Group was approved as an authorised maintenance services provider of fire prevention and fighting systems by Fire Service Department of Fujian Province. According to the Directors, the Group is currently one of the enterprises that has obtained such an approval in the Fujian Province. As the Group did not commence the Maintenance Services until June 2001, the turnover generated from such business before the provision of sales tax only amounted to approximately RMB2.6 million for the year ended 31st December, 2001 and turnover generated from Maintenance Services increased substantially to RMB7.3 million for the seven months ended 31st July, 2002. For the seven months ended 31st July, 2002, the Group completed 12 projects and continued to provide installation services to 14 projects in fire prevention and fighting systems installation in Fujian Province and recorded revenue of approximately RMB50.9 million, after the provision of sales tax of approximately RMB1.7 million.

Revenue generated from Maintenance Services for the seven months ended 31st July, 2002 increased substantially to approximately RMB7.1 million, after the provision of sales tax of approximately RMB0.2 million. The Directors consider that the substantial increase in Maintenance Services was mainly attributable to the tightening of reinforcement of fire safety regulations especially after the announcement of Regulation of Fire Safety Administration for Governmental Offices, Organisations, Corporations and Business Units《機關、團體、企業、事業單位消防安全管理規定》 in October 2001. The Directors believe that the turnover generated by Maintenance Services will continue to increase in the coming years given the lack of competition and the tightening of the enforcement of fire prevention laws and regulations.

## **GENERAL OVERVIEW OF THE GROUP**

The Group has a team of approximately 3 engineers and 2 technicians providing maintenance services. The engineers and technicians are qualified professionals and some of them have been working for the Group for about 2 years. Maintenance services provided by the Group are normally performed on a quarterly basis and include inspection, functional tests and replacement of parts for the fire prevention and fighting systems. The above mentioned turnover before the provision of sales tax of RMB2.6 million for the year ended 31st December, 2001 and RMB7.3 million for the seven months ended 31st July, 2002 did not include the sales of parts for the replacement. The sales of parts with such connection amounted to about RMB256,000 and RMB870,000. The Directors believe that the additional sales of parts arising from the provision of maintenance services by the Group give rise to additional income.

### **INSURANCE**

The Group keeps an insurance policy against damages to its head office and principal place of business in the PRC. The Group also maintains adequate insurance coverage for its employees who are exposed to high risks in respect of death or personal injury at work. To the best knowledge of the Directors, there is currently no suitable product liability insurance for the Group's products in the PRC. Therefore, the Group does not maintain any product liability insurance. The Group has not experienced any third party liability claim in relation to its products. Since each product of the Group is under strict quality control procedures on production (details as set out in "Quality Control" in this section) and the Group usually provides one year maintenance period for its Products Sales, the Directors consider that the risk of product liability is remote.

### **AFTER-SALE AND AFTER INSTALLATION SERVICES**

The Group aims to provide high quality customer services by providing timely repair, maintenance services and technical assistance to its customers. For all products delivered, the Group normally offers free replacement of products within three months after delivery and a one year free-of-charge repair warranty to enhance customers' confidence and loyalty. For the two years ended 31st December, 2001 and for the seven months ended 31st July, 2002, total expenditure on after-sales and after-installation services amounted to approximately RMB45,500, RMB23,500 and RMB12,000, respectively. The Group has a customer services team of 17 persons providing necessary training and technical support to the customers. In addition, the customer services team also operates a direct service hotline handling complaints or enquiries from customers. To ensure timely response, any complaint or enquiry has to be answered within 48 hours and any repair has to be made within a prescribed time ranging from 2 to 5 working days depending on the type of product. The sales offices carry out co-ordination work and are responsible to ensure that timely and helpful advice are provided to customers in their respective regions. The Directors believe that this arrangement helps to enhance the relationship between the Group and its customers. The Directors believe that the Group performs excellent customer services in the PRC and has received no complaint as at the Latest Practicable Date.

### **RESEARCH AND DEVELOPMENT**

New and/or improved products have been put into the market from time to time in response to the changing needs of its customers and technological changes. Special emphasis has been placed on the research and development of emergency lighting system and fire alarm system. The research and development functions of the Group is currently carried out by (i) an internal research and development team; and (ii) engagement of universities and science institutions.

The Group currently has a research and development team of 12 staff members. The research and development team is mainly responsible for the research in the improvement of the

## GENERAL OVERVIEW OF THE GROUP

functionalities of the Group's existing products and the development of new products. In the past 4 years, the team has conducted systematic investigation of the properties of different parts and modules of components (e.g. lighting sources for emergency lights and integrated circuits for fire sensors) and the functions of such under different situation and environment and draw conclusions from such findings for the development of a number of emergency lights and fire alarm system. During the Track Record Period, the research and development team of the Group designed and developed different types and models of emergency lightings and equipment for fire alarm systems. The Group has obtained 16 patents in respect of the products developed by the Group's research and development team. For details of the patents, please refer to the paragraph headed "Intellectual Property Rights" in this section.

In order to leverage on the strength of universities and science institutions in the PRC, the Group also co-operates with them on the research and development of new products.

On 20th December, 2001, Fujian Wanyou entered into a research and development co-operation agreement with Research Institute of Fuzhou University (福州大學科技開發總公司) ("Fuzhou Research Institute") pursuant to which Fujian Wanyou undertakes to pay an amount of RMB2 million annually commencing from December 2002 as expenditure for research and development of fire safety related technology and newly developed products undertaken by approximately 20 research experts. Fuzhou Research Institute will be responsible for the development of fire alarm and fire safety monitoring technology. It will also carry out the design and structuring of the production plan for the products it developed. In consideration of such payment, both parties agree that research result, patent rights and knowhow of such fire safety related technology and newly developed products will belong to Fujian Wanyou and no consideration will be paid for transfer of such results and information relating thereto. Such agreement is on a continuous basis without an expiry date. Currently, the Directors expect that the Group will not terminate such agreement in the near future.

On 16th January, 2002, the Group entered into a technology service agreement with Shenyang Research Institute on Fire Prevention and Fighting Technology under the Ministry of Public Security (公安部瀋陽消防科學研究所) ("Shenyang Research Institute"). Pursuant to the agreement, the Group engaged Shenyang Research Institute to perform research and development of an advanced smoke detector comprising integrated circuits and telecommunication technologies. Shenyang Research Institute has engaged about 10 experts in the project. Upon completion of such agreement, all rights in relation thereto shall belong to the Group and the Group shall pay Shenyang Research Institute a consideration of RMB1.7 million. Although the agreement is a one-off assignment, the Directors believe that similar co-operation with Shenyang Research Institute will continue in the future.

The Group will continue to invest in the research and development of new products and the enhancement of existing products. For the two years ended 31st December, 2001 and for the seven months ended 31st July, 2002, the total expenditure on research and development materials were approximately RMB209,000, RMB168,000 and RMB182,000 respectively. The nature of the research and development expenditure for the two years ended 31st December, 2001 were solely costs for materials. The Group had incurred significant expenditure before 2000 (approximately HK\$1.4 million) on the development of the Group's product and the research and development expenditure incurred during the two years ended 31st December, 2001 and for the seven months ended 31st July, 2002 were mainly expenditure for the enhancement of the Group's products.

## GENERAL OVERVIEW OF THE GROUP

In order to capture the latest information on the development of fire prevention and fighting equipment, the Group incorporated Wang You Fire Technology Limited, an indirect wholly owned subsidiary of the Company in Delaware, U.S.A., in March 2002, to perform research on the development of fire prevention and fighting equipment.

### INTELLECTUAL PROPERTY RIGHTS

As at the Latest Practicable Date, the Group has obtained in the PRC 7 design patents (外觀設計專利), 8 patents for utility model (實用新型專利) and 1 patent for invention (發明專利). Details of intellectual property rights are referred to paragraph headed “Intellectual property” in Appendix IV to this prospectus.

### COMPETITION AND COMPETITIVE STRENGTH

The Directors believe that the market for fire prevention and fighting systems is competitive and fragmented in the PRC. Competition is expected to persist and intensify in the future with the growing demand for fire prevention and fighting systems as a result of the prosperity of the property development market in the PRC. With the hosting of Olympic Games by Beijing in 2008, the Directors anticipate that contracts for fire prevention and fighting systems will increase significantly and there will be intense competition bidding for the projects. The Directors believe that the key of success in the market of fire prevention and fighting system is to provide efficient and cost-effective fire prevention and fighting equipment with innovative and new technologies. In addition, a comprehensive distribution network and an efficient customer support system that provides training and maintenance facilities are essential to the success in the PRC fire prevention and fighting equipment market.

#### (i) Equipment of fire detection and alarm systems

According to the information published by CFPA in 2001, there are about 100 domestic manufacturers and about 30 foreign enterprises distributing fire detection and alarm systems and the largest 20 brands account for about 80% of the market share.

The Group's products are widely distributed in the cities of the PRC. For the year ended 31st December, 2000, approximately 60.0% of the fire detection and alarm products were distributed in Fujian Province. Beijing, Shanghai and other cities of the PRC accounted for about 3.4%, 14.0% and 22.6% of the Group's sales of fire detection and alarm products respectively. For the year ended 31st December, 2001, the respective sales of the above-mentioned were approximately 66.0%, 13.4%, 12.4% and 8.3% in Fujian Province, Beijing, Shanghai and other cities. For the seven months ended 31st July, 2002, the respective sales of the above-mentioned were approximately 39.1%, 18.7%, 16.3% and 25.9% in Fujian Province, Beijing, Shanghai and other cities. The Directors believe that the Group's success of becoming one of the most competitive suppliers is mainly due to its outstanding quality and user-friendliness of the products. The Directors consider that the Group's Installation Services operation contributes and supports the Group's product development and improvement as installation projects gather market and technical information from the customers. In addition, the Group's Installation Services team provides speedy repair and maintenance to ensure the quality and after sales services to its product customers.

#### (ii) Lighting products

Being one of the entities participated in the drafting of the PRC National Standards for Fire Emergency Luminaries, the Group is considered to have the strength to compete in this sector. Its products have not only been sold to Fujian Province but have also been distributed all over the



## GENERAL OVERVIEW OF THE GROUP

PRC. For the year ended 31st December, 2000, approximately 60%, 3.1%, 17.7% and 19.2% of the Group's sales of fire emergency lighting products were distributed in Fujian Province, Beijing, Shanghai and other cities of the PRC, respectively. For the year ended 31st December, 2001, Fujian Province, Beijing, Shanghai and other cities in the PRC accounted for about 64.5%, 11.7%, 18.2% and 5.6% of the Group's sales of fire emergency lighting products respectively. For the seven months ended 31st July, 2002, the respective sales of the above-mentioned were approximately 58.9%, 5.3%, 7.2% and 28.6% in Fujian Province, Beijing, Shanghai and other cities respectively. The Directors believe that the Group will continue to lead the fire emergency lighting market in terms of technology and quality and hence sustains its leading position in the fierce competition in future.

### (iii) Installation Services

The customers of the Group's Installation Services are mainly concentrated in Fujian Province as the Directors consider such a market is generally segmented and regional whereas the localisation of skilled labour force and market information creates a barrier to cross province operation. From the Group's track record in Fujian Province, the Directors believe that the Group is the leading Installation Services provider in the region and the Directors do not expect any substantial competitors shall emerge in the future. As the Group grows further, the Directors intend to bid for some of the important Installation Services projects outside Fujian Province for economic benefits and establishment of recognition which will in turn benefit the Group's Product Sales.

### (iv) Repair and maintenance

The Directors believe that the Group will not encounter much competition in the repair and maintenance sector in Fujian Province. To the best knowledge of the Directors, the Group is currently one of the few enterprises that has been awarded license to carry out repair and maintenance services on fire prevention and fighting systems. Although it is not an intention for the Group to extend the services regions outside Fujian Province in the near future, the Directors believe that the Group would also be competitive nation wide after accumulating more experience and recognition.

The Directors believe that the Group has the following competitive advantages over its competitors:

#### 1. Integrated scope of business

According to CFPA, there are only a few companies in the PRC that have a full array of licenses to operate integrated business in the design, manufacturing, installation and maintenance of fire prevention and fighting systems, which the Directors believe the Group is one of them. The Directors consider that the provision of Installation Services enables the Group to accumulate information and learn about market demands, which is favourable for the development of the Group's products. On the other hand, the design and manufacturing capability of the Group provide it with competitive advantage in the Installation Services.

#### 2. Emphasis on research and development

The Group places strong emphasis on research and development and has formed an experienced team in the PRC to conduct research and development. In addition, the Group engages research and academic institutions such as Research Institute of Fuzhou University (福州大學科技開發總公司) ("Fuzhou Research Institute") and Shenyang Research Institute

## GENERAL OVERVIEW OF THE GROUP

on Fire Prevention and Fighting Technology under the Ministry of Public Security (公安部瀋陽消防科學研究所) (“Shenyang Research Institute”) to undertake research and development projects. Such co-operation allows the Group to capitalise on the specialised knowledge in fire prevention and fighting products. Currently, the Group is devoted to the improvement of the quality and functionality of the control station of fire alarm system; in particular, the compatibility of the Group’s fire alarm system with the sensors of the majority of fire alarm system manufacturers. The Directors believe that through research and development, the Group will be able to increase its market share and maintain profit margin on a technology driven basis.

### 3. Established reputation and product recognition

The Group has been engaged in the fire prevention and fighting products industry since 1995 and has built a reputation in the PRC for delivering high quality fire prevention and fighting products. The Group’s products are sold in major cities in the PRC, namely, Fuzhou, Beijing and Shanghai. In addition, owing to the high recognition by National Quality and Technology Supervision Bureau (國家質量技術監督局) of the Group’s fire prevention and fighting products, the Group has been invited to participate in the formulation of the national standard of fire emergency luminaries in the PRC.

### 4. Protection by patents

The Group has obtained 16 patents on its fire prevention and fighting equipment in the PRC. As the production of fire prevention and fighting systems require Certificates of Conformity of Product Quality (產品質量認證證書) issued by CCCFP under the Ministry of Public Security, any patent infringing equipment from other manufacturers will not be granted such certificate and sales of such infringing products are prohibited.

### 5. Effective and extensive distribution network

The Group’s Product Sales are extensively dispersed all over the PRC. The Group has established a nation wide distribution network mainly maintained by the Group’s 16 branch offices as well as 17 distributors in major cities in the PRC. The well established network provides effective means for the Group to capitalise on its research and development capacity and management efficiency to magnify its market shares.

### 6. Focused and experienced management

The Group’s management team members, in particular, Mr. Jiang Xiong and Mr. Jiang Qing, are highly specialised and experienced in the fire prevention and fighting systems and equipment business. The continuity, in-depth expertise and experience of the Group’s management team enable the Group to compete in the industry effectively and efficiently.

### 7. Well-established relationship with relevant authorities

Apart from building its professional capability, the Group has also established relationships with various parties including the relevant fire services departments, organisations and property developers. The Group has been invited by Fujian Province General Bureau of Fire Services (福建省公安消防總隊) to participate in fire alarm system promotional and introductory programmes. The Directors believe that such well-established relationships benefit the Group in terms of building up reputation, and better access to the latest industrial information and know-how.

# GENERAL OVERVIEW OF THE GROUP

## 8. Favourable foundation for future development

The Directors believe that the fire service equipment market in the PRC is enormous. In particular, the fire service departments at all levels in the PRC purchase fire prevention and fighting equipment and fire services supplies for approximately RMB3 billion each year. The Group was qualified as a supplier of fire prevention and fighting products to the Fujian Provincial Government in June 2001 and is one of the few enterprises providing fire prevention and fighting equipment which has obtained such qualification in the Fujian Province. The Directors believe that the Group has laid a good foundation for future development in the fire service equipment to governmental bodies.

## 9. Strong shareholders' support

The Group's strategic investors are reputable companies, namely, Cantus, a wholly-owned subsidiary of Aria, a pan-Asian private equity fund managed by CLSA Private Equity Management Limited, YMW, a Japanese-based investment union managed by Yamaichi Hands-on Associates Inc. and Morita, a company engaged in the manufacturing and distribution of fire engines and fire prevention vehicles, whose shares are listed on the Osaka Stock Exchange Limited and Tokyo Stock Exchange Limited. The Directors believe its alliance with Cantus and YMW may provide the Group with extensive business connections via Cantus and YMW's portfolio of investments, whereas its alliance with Morita may aid the Group in the development of its fire engine distribution and other related equipment business. Moreover, the Group may obtain the latest technological know-how from Morita in order to enhance the quality of its services and products. For details, please refer to the section headed "Strategic Investors" on pages 79 to 81 of this prospectus.

## AWARDS AND CERTIFICATIONS

The Group has received a number of awards from its banker and relevant PRC governmental and professional bodies in relation to the quality and technological advancement of its products:

Date of grant	Award	Awarding Organisation	Background of the award
April 1995	Civilised Youth Unit  (青年文明號)	Central Committee of Chinese Communist Youth League (共青團中央委員會) SAIC (國家工商行政管理局) China Individual Labourers' Association (中國個體勞動者協會)	– Honorary award at national level to enterprises with outstanding performances and excellent services. The award has been issued since 1994 and 45 enterprises were awarded so far
April 1996	1995 Modern Private Enterprise of Fuzhou City (1995年度福州市先進私營企業)	Fuzhou Administration for Industry & Commerce (福州市工商行政管理局) Fuzhou Private Enterprise Association (福州市私營企業協會)	– City award to enterprises with excellent services and clean history of tax payments

## GENERAL OVERVIEW OF THE GROUP

Date of grant	Award	Awarding Organisation	Background of the award
February 1997	Modern Private Enterprise (先進私營企業)	Fujian Municipal People's Government Administration Bureau for Industry and Commerce (福建省人民政府 工商行政管理局)	– provincial award to enterprises with excellent services and clean history of tax payments
September 1997	“excellent construction servicing unit” for Fuzhou Changle Airport (福州長樂國際機場工程 建設優質服務單位)	Fuzhou Municipal People's Government (福州市人民政府)	– outstanding performance on servicing the major construction project of provincial government
March 1998	Price & Measure Trustworthy Enterprise (「物價·計量信得過」單位)	Taijiang District Price Administration Bureau (台江區物價局)	– 63 enterprises in Fuzhou City were awarded on their fair prices and good product quality
May 1998	First award for One of the Best Ten Civilised Youth Units of the Fujian Province (首屆福建省十佳青年文明號)	Fujian Province Creative and Civilised Youth Unit Activity Committee (福建省創建青年文 明號活動組委會)	– Honorary award to 10 most outstanding enterprises in the Fujian Province
June 1998	1997-1998 Fuzhou City “Best Ten” Private Enterprises (1997-1998年度福州市「十強」 私營企業)	Fuzhou Municipal Committee of the PRC (中共福州市委) Fuzhou Municipal People's Government (福州市人民政府)	– 10 outstanding enterprises with excellent services and outstanding performances
July 1998	(1994-1997) Outstanding Patented Enterprise of the Fujian Province (1994-1997年) 福建省專利優秀企業)	Fujian Province Committee of Science and Technology (福建省科學技術委員會) Fujian Province Patent Administration Bureau (福建省專利管理局)	– Honorary award to enterprises with outstanding patent record
November 1998	High and New Technology Enterprise (高新技術企業)	Fujian Province Committee of Science and Technology (福建省科學技術委員會)	– Recognition on its high technology status
February 1999	1998 Outstanding trademark of Fuzhou City (1998年福州市著名商標)	Fuzhou Municipal People's Government (福州市人民政府)	– Honorary award to enterprises with well- known reputations on product quality and high market share

## GENERAL OVERVIEW OF THE GROUP

Date of grant	Award	Awarding Organisation	Background of the award
September 1999	1997-1998 Fuzhou City Contractual Responsibility and Trust-worthiness Safe-guarded Entity (1997年－1998年福州市重合同、守信用單位)	Fuzhou Municipal People's Government (福州市人民政府)	– city award to enterprises with good credit history
June 2000	1999 AAA Credit Enterprise (一九九九年度AAA級信用企業)	Agriculture Bank of China, Fujian Province Branch (中國農業銀行福建省分行)	– special award on credit worthiness of the enterprise
March 2001	Contractual Responsibility and Trust-worthiness Safe-guarded Entity (重合同守信用單位)	Fuzhou Province Administration of Industry and Commerce (福建省工商行政管理局)	– special award on credit worthiness of the enterprise
April 2001	2000 AAA Credit Enterprise (二零零零年度AAA級信用企業)	Enterprise Credit Assessment Committee of Agriculture Bank of China, Fujian Province Branch (中國農業銀行福建省分行企業資信評審委員會)	– special award on credit worthiness of the enterprise
June 2001	Qualified Supplier of Fujian Provincial Government (福建省政府採購准入資格証)	Office of purchase committee of the Fujian Provincial Government (福建省政府採購委員會辦公室)	– one of designated parties for provincial government purchases
October 2001	2000 Outstanding trademark of Fuzhou City (2000年福州市著名商標)	Fuzhou Municipal People's Government (福州市人民政府)	– award on well-know reputation, good product quality and high market share
December 2001	1999-2000 Contractual Responsibility and Trust-worthiness Safe-guarded Entity (1999-2000年度重合同、守信用單位)	Fuzhou Municipal People's Government (福州市人民政府)	– city award on good credit history
December 2001	Contractual Responsibility and Trust-worthiness Safe-guarded Entity (重合同守信用單位)	the head office of SAIC (國家工商行政管理總局)	– national award on good credit history and 520 enterprises in the PRC were given such award

# GENERAL OVERVIEW OF THE GROUP

## STRATEGIC INVESTORS

### Cantus

Cantus is an investment company, being a wholly-owned subsidiary of Aria, a pan-Asian private equity fund managed by CLSA Private Equity Management Limited, a specialist private equity investment management firm focused on Asian equity investment. CLSA Private Equity Management Limited, a company incorporated in the British Virgin Islands on 13th August, 1998, belongs to the CLSA Emerging Markets Group.

Aria is an exempted limited partnership organised under the laws of the Cayman Islands on 18th April, 2000. CLSA Private Equity Management Limited is the general partner and manages the partnership on a discretionary basis. CLSA Private Equity Management Limited does not have any other business other than being the general partner of Aria. The partnership's objective is to achieve substantial long-term capital appreciation through the purchase, investment management, and disposition of a portfolio of direct investments in equity and equity related securities of companies operating directly or indirectly in the target markets. Currently, Aria has six limited partners, one special limited partner and one general partner, all of which are independent of the Initial Management Shareholder, Directors and chief executives of the Company and their respective associates. The partnership's investment commitments are approximately US\$75 million and its portfolio companies include various sectors namely, media, consumer products and retail industries. As Aria has investments in consumer products, service and manufacturing industries, the Directors expect that this alliance will lead to an increase in opportunities for the Group to offer various fire prevention and fighting products and services to potential clients. In addition, CLSA Emerging Markets Group has extensive business connections in Asia and is able to introduce reputable partners to the Group in developing new business lines and regional markets.

On 1st March, 2002, Cantus was issued 1,000 shares in the capital of Wang Sing, the then holding company of the Group at a consideration of approximately HK\$40 million, pursuant to a share subscription agreement dated 27th February, 2002 entered into with Wang Sing and Mr. Jiang Xiong. Under an escrow agreement dated 1st March, 2002, Mr. Jiang Xiong agreed to pay or procure the payment of US\$5,128,205 ("Escrow Amount") to CLSA Limited ("Escrow Agent") and the Escrow Agent agrees to credit such payment into an account for the credit of CLSA Limited held at Credit Lyonnais, New York (the "Escrow Account"). Such Escrow Amount (together with all interest accrued thereon) shall be released to Mr. Jiang Xiong if the listing date of the initial public offering or completion of a sale of the business of the Group takes place on or before 31st December, 2002 ("Escrow Release Deadline") which may be extended to 31st December, 2003 if Cantus agrees (the "Extended Escrow Release Deadline") or shall be released to Cantus if the Company fails to achieve (i) the listing of its shares or (ii) the sale of substantially all the assets or securities of the Group, on or before the Escrow Release Deadline or the Extended Escrow Release Deadline, as the case may be. On 4th July, 2002, Cantus and Mr. Jiang Xiong verbally agreed to terminate such escrow agreement and the Escrow Agreement was terminated on 4th September, 2002. Pursuant to the Reorganisation, the 1,000 shares of Wang Sing were exchanged for 160,000,000 Shares. Immediately following the completion of the Placing and assuming the Over-allotment Option is not exercised, Cantus will hold 160,000,000 Shares representing approximately 8.00% of the enlarged issued share capital of the Company.

The shareholder and directors of Cantus are independent of the Company, the Directors and their respective associates.

## GENERAL OVERVIEW OF THE GROUP

### YMW

YMW is a Japanese-based investment union which is approved by Japanese Civil Law Article 667 and its main activity is to invest in venture companies that are not listed on any stock exchanges. The portfolio size of YMW is approximately ¥163 million and has 25 fundholders, all of which are independent of the Initial Management Shareholder, directors and chief executives of the Company and their respective associates. Yamaichi Hands-on Associates Inc., being one of the fundholders, is also the general partner of YMW and manages YMW for the fundholders on a discretionary basis.

Yamaichi Hands-on Associates Inc. was established in Japan in December 2000 with a capital base of ¥50 million as at the Latest Practicable Date. It manages 2 funds, namely Yamaichi Hands-on No. 1 Fund and YMW, and the total size of these funds are approximately ¥210 million as at the Latest Practicable Date. The investment of YMW is beneficial to the Group since it may lead to various forms of co-operations and joint business development.

On 1st March, 2002, YMW was issued 219 shares in the capital of Wang Sing, the then holding company of the Group at a consideration of approximately HK\$8.75 million, pursuant to a subscription agreement dated 27th February, 2002 entered into with Wang Sing and Mr. Jiang Xiong. Mr. Jiang Xiong has undertaken to YMW that should the Company fail to list its shares by 31st December, 2002, Mr. Jiang Xiong will purchase the shares in Wang Sing held by YMW at the subscription price paid by YMW. On 4th July, 2002, YMW and Mr. Jiang Xiong verbally agreed to terminate such undertaking made by Mr. Jiang Xiong and the two parties entered into written termination agreement on 4th September, 2002. Pursuant to the Reorganisation, the 219 shares of Wang Sing were exchanged for 35,040,000 Shares. Immediately following the completion of the Placing and assuming the Over-allotment Option is not exercised, YMW will own 35,040,000 Shares, representing approximately 1.75 per cent. of the enlarged issued share capital of the Company.

Each of YMW, Cantus and Morita entered into a separate subscription agreement with Wang Sing and Mr. Jiang Xiong on 27th February, 2002 on substantially the same terms to subscribe for shares of Wang Sing and following commercial negotiations, YMW agreed to restrictions on disposal of its Shares as if it were a Significant Shareholder.

Save as disclosed in this section, the fundholders and directors of YMW are independent of the Company, the Directors and their respective associates and are not involved in the management of the Group nor have they nominated any director to the Company.

### Morita

Established in 1907, Morita mainly engages in the manufacturing and distribution of fire engines and fire prevention vehicles. Morita is listed on the Osaka Stock Exchange Limited and Tokyo Stock Exchange Limited. The market capitalisation of Morita as at the Latest Practicable Date is approximately JPY18,512.35 million, equivalent to approximately HK\$1,203.30 million. It has substantial achievements and leading position in the realm of fire prevention and fighting equipment.

On 1st March, 2002, Morita was issued 146 shares in the capital of Wang Sing, the then holding company of the Group at a consideration of approximately HK\$5.83 million, pursuant to a subscription agreement dated 27th February, 2002 entered into with Wang Sing and Mr. Jiang Xiong. Mr. Jiang Xiong has undertaken to Morita that should the Company fail to list its shares by 31st December, 2002, Mr. Jiang Xiong will purchase the shares in Wang Sing held by Morita at

## GENERAL OVERVIEW OF THE GROUP

the subscription price paid by Morita. On 4th July, 2002, Morita and Mr. Jiang Xiong verbally agreed to terminate such undertaking made by Mr. Jiang Xiong and the two parties entered into a written termination agreement on 4th September, 2002. Pursuant to the Reorganisation, the 146 shares of Wang Sing were exchanged for 23,360,000 Shares. Immediately following the completion of the Placing and assuming the Over-allotment Option is not exercised, Morita will own 23,360,000 Shares, representing approximately 1.17 per cent. of the enlarged issued share capital of the Company.

Each of Morita, Cantus and YMW entered into a separate subscription agreement with Wang Sing and Mr. Jiang Xiong on 27th February, 2002 on substantially the same terms to subscribe for shares of Wang Sing and following commercial negotiations, Morita agreed to restrictions on disposal of its Shares as if it were a Significant Shareholder.

Save as disclosed in this section, the substantial shareholders and directors of Morita are independent of the Company, the Directors and their respective associates and are not involved in the management of the Group nor have they nominated any director to the Company.

The strategic alliance with Morita is beneficial to the Group as it allows the Group to obtain leverage on the industry expertise of Morita. The Group will develop the business of fire engine distribution and other related equipment. In addition, the strategic alliance will also lead to various forms of co-operations and joint business development.

In February 2002, the Group entered into a letter of intent with Morita, one of the largest fire engine manufacturers in the world. Pursuant to such agreement, the Group has been appointed as the sole distributor of Morita in southern China to market Morita's fire engines to relevant fire stations. The parties are in the process of negotiation, the details of terms of the agreement such as consideration, minimum purchase requirements and delivery and payment have not yet been finalised as at the Latest Practicable Date. Upon finalisation of the details of terms, Morita and the Group will enter into a formal agreement and commence cooperation, for which the Directors expect to materialise in early October 2002. Both Morita and the Group expressed that an agency basis of cooperation is a starting point for both parties collaboration and they are looking forward to a higher level of cooperation, such as joint venture of manufacturing bases, in the future.

### **Basis of valuation in respect of the placing of Wang Sing's shares to the strategic investors**

The Directors confirm that the subscription price paid by each of Cantus, YMW and Morita were arrived at arm's length negotiations. The discount on the subscription price was offered to the subscribers as the Directors were of the view that (i) both Cantus (as an investment vehicle of CLSA) and YMW would enhance its shareholders' base owing to their international reputation; (ii) the investment by Morita will create synergy with the Group as the Group would be able to obtain leverage on Morita's industry expertise and develop future business co-operations; and (iii) these strategic investors have given undertaking to place in escrow the Shares held by them with an escrow agent and not to dispose of any of its interest in the Company for a period of six-months from the Listing Date.

### **COMPETING INTERESTS**

None of the Directors, Initial Management Shareholder, Substantial Shareholder or Significant Shareholder referred to in the section headed "Substantial shareholder, initial management shareholder, significant shareholder and other shareholders" or any of their respective associates has an interest or hold directorship in any business which constitutes or may constitute competition to the Group.



# GENERAL OVERVIEW OF THE GROUP

## RELATED PARTY TRANSACTIONS

During the Track Record Period, the Group obtained financing from Fujian Wanan for its operations. The amounts due to Fujian Wanan as at the two years ended 31st December, 2001 and for the seven months ended 31st July, 2002 were approximately RMB3,200,000, RMB3,800,000 and nil respectively. In addition, Fujian Wanan had also provided corporate guarantee for the Group's bank loans amounting to RMB4,000,000 as at 31st December, 2001. The bank loans were subsequently repaid in June 2002 and the corporate guarantee was released accordingly. During the Track Record Period, Fujian Wanan was owned as to 70% by Ms. Liang Jin Wen, the spouse of Mr. Jiang Xiong, 20% by Mr. Liang Xun Lin, Mr. Jiang Xiong's father-in-law and 10% by Mr. Chen Shu Quan, the executive Director of the Group from March 1999 to August 2001 and thereafter until February 2002 held as to 90% by Ms. Liang Jin Wen and 10% by Mr. Chen Shu Quan. Fujian Wanan was engaged in the manufacturing of computer parts. Save for the holding of 31.19% equity interest in Wanyou Engineering from August 1998 to March 2001, Fujian Wanan had no material business. Apart from these transactions, Fujian Wanan had no other business transactions with the Group. In February 2002, Ms. Liang Jin Wen and Mr. Chen Shu Quan disposed their 90% and 10% equity interests, respectively to two independent parties. (Mr. Liang Xun Lin transferred all his equity interests in Fujian Wanan to Ms. Liang Jin Wen at cost in August 2001). Since then, Fujian Wanan is independent from the Company, the directors, chief executives, Significant Shareholder and Initial Management Shareholder or their associates.

Save as disclosed above and in the paragraph headed "Related party transactions" of the accountants' report, the text of which is set out in Appendix I to this prospectus, during the two years ended 31st December, 2001 and the seven months ended 31st July, 2002 and up to the Latest Practicable Date, the Company has not entered into any material related party transactions. In addition, none of the related party transactions disclosed above will continue after the listing of the Company. The Directors are of the opinion that the related party transactions in relation to the financing were carried out on normal commercial terms and in the best interest of the Company.

# STATEMENT OF BUSINESS OBJECTIVES

## THE GROUP'S MISSION

The mission of the Group is to become a leader in the PRC fire prevention and fighting industry. The Directors believe that the Group's mission can be achieved essentially by the application of the latest technology, enhancement of quality and expansion of sales network. The Directors are also convinced that a more predictable growth of the Group shall be derived from the expansion of its existing businesses and the exploration of new products in the fire prevention and fighting industry should also provide the Group with numerous opportunities.

## BASES AND ASSUMPTIONS

The Directors have assessed the potential of the market and formulated the proposed strategies during the Forward Looking Period to achieve the Group's business objective on the basis of the industry historical trend, as well as the anticipated future growth and expected demand based on the Directors' experience and knowledge. The Directors have made the following principal assumptions in making such assessment and formulation:

- (i) There will be no material adverse changes in the existing political, legal, fiscal, foreign trade or economic conditions in the PRC, Hong Kong or other countries in which the Group operates or to which the Group's operation may expand during the Forward Looking Period;
- (ii) There will be no revocation in the licenses and permits that the Group has obtained;
- (iii) There will be no material changes in the bases or rates of taxation of those countries in which the Group operates or its subsidiaries are incorporated or established;
- (iv) There will be no material changes in the interest rates or foreign currency exchange rates from those countries prevailing;
- (v) The Group will not encounter any problem or disruption adversely affecting its operations or development plans in any way, including but not limited to:
  - (a) shortage or disruption in supplies of electronic parts;
  - (b) industrial accidents, natural or political disasters;
  - (c) malfunctioning of the Group's machinery and equipment;
  - (d) labour disputes or industrial actions;
  - (e) any other force majeure event; and
  - (f) unsuccessful or delayed launch of new products or new types of services.

# STATEMENT OF BUSINESS OBJECTIVES

## MARKET POTENTIAL

The Directors believe that the economy together with the property market in China will continue to grow in the foreseeable future and this will create significant demand for fire prevention and fighting systems. The Directors also believe that the State will continuously strengthen the enforcement of laws and regulation relating to fire prevention and fighting. In addition, the Directors consider that new opportunities will arise from the budget of fire service product supplies earmarked for the fire service departments in every city in the PRC. Capitalised on the existing advantageous position, the Group is confident of being able to capture a significant portion of the future market potential in China owing to the factors set out as follows:–

### Tightening of laws and regulations

“The Fire Services Law of the PRC” (“中華人民共和國消防法”) was promulgated in 1998 and has set a proper legal framework to enhance fire safety. Section 8 of the Fire Services Law requires governments of different cities to include the implementation of fire prevention and fighting equipment as part of the city planning. In addition, it also promotes the governments to put more funds on the development of fire prevention and fighting technology and the application of advanced fire prevention and fighting equipment. Hence, the development of the fire prevention and fighting industry has been experiencing a continuous growth. The Administrative Office of the Fire Prevention and Fighting Product Industry (消防產品行業管理辦公室) under the Ministry of Public Security has concerns over the development of the industry. It has set policies for the industry and reforms in the regulatory system of fire prevention and fighting products. It has also established a nationwide network relating to the quality of fire prevention and fighting products and gradually implemented the system of conformity of product quality and conformity of fire prevention and fighting product model. According to “Fire Protection Weekly Journal under the China Public Security Daily” (“人民公安報消防周刊”), the fire prevention and fighting industry in the PRC will grow significantly at an annual growth rate of 15% to 20% and the annual total value of production for the next five years will be approximately RMB35 billion to RMB40 billion.

In addition to rectification of the existing fire prevention and fighting systems, the Fire Services Law and regulations have also imposed stringent requirements for repair and maintenance of the existing fire prevention and fighting systems. As public fire prevention and fighting facilities require annual repair and maintenance, RMB9 billion will be spent on repair and maintenance of fire prevention and fighting systems in the PRC per annum according to “Fire Protection Weekly Journal under the China Public Security Daily” (“人民公安報消防周刊”).

### New projects accompanied by new construction projects and developments

According to the Tenth Five Year Plan of the PRC Central Government, the total gross floor area for residential buildings in cities and villages during the next five years is estimated to be 5,700 million sq.m., including 2,700 million sq.m. for residential buildings in cities and 3,000 million sq.m. for residential buildings in villages. In addition, the total gross floor area for newly constructed buildings in cities is estimated to be 5,000 million sq.m. during the next five years and qualified fire services installation must be installed in all newly erected buildings. Extracted from “Fire Protection Weekly Journal under the China Public Security Daily” (“人民公安報消防周刊”), assuming that the budget for fire prevention and fighting systems installation is around RMB100-150 per sq.m. in accordance with the market practice of property development, the total market value will be approximately RMB50-75 billion in the PRC during the next 5 years.

# STATEMENT OF BUSINESS OBJECTIVES

## Government promotion

With the continued and rapid growth of the PRC economy, the degree of urbanisation and industrialisation has been increasing rapidly. All levels of government in the PRC have placed significant concerns over the development of fire safety and the investments in urban fire prevention and fighting systems installation are increased accordingly. In addition, many new industrial, commercial, cultural and sports facilities are being constructed in all major cities in recent years and these facilities have different requirements on fire prevention and fighting systems. According to “Fire Protection Weekly Journal under the China Public Security Daily” (“人民公安報消防周刊”), approximately RMB200 billion will be spent in building facilities for the 2008 Olympic Games in Beijing and projects for fire prevention and fighting systems installation will account for 6%-11% of the total budget which is equivalent to about RMB12-22 billion based on industrial estimate. The Directors believe that the potential is enormous in the PRC.

## Modernisation of equipment for fire services departments

Accompanied with the robust growth in the economy and the increasing demand of society, the Directors believe that quality of the equipment for fire services departments in different areas in the PRC has been improving. To further enhance equipment to an advanced international standard, different governments of provinces and cities in the PRC have been earmarking considerable budgets for purchase of supplies to fire stations. According to “Fire Protection Weekly Journal under the China Public Security Daily” (“人民公安報消防周刊”), the fire service departments in all levels of government in the PRC purchase fire prevention and fighting equipment and supplies of approximately RMB3 billion each year. The Directors believe that supplying equipment to fire services department will provide opportunities to the Group.

## OBJECTIVES OF THE GROUP

The Group’s objective, together with its proposed strategies and implementation plans to achieve the objective, in respect of each of the principal activities, during the Forward Looking Period are described below.

### Objectives

The Group’s objective during the Forward Looking Period is to set a path for the achievement of the Group’s mission stated above. The Directors consider that the following means are practicable to accomplish the Group’s objectives:

1. The Group shall capitalise on the advantages of the existing business and expand the Group’s market share. The Directors believe that the Group shall be able to lead the industry with its technology as well as marketing strategy. The Directors consider that a throughout penetration to the national sales network would be an effective mean to assist the Group to gain a larger market share.
2. In addition to the existing business, a horizontal development into other product lines would bring extra earnings to the Group on top of the growing business carried out by the Group. However, such ventures should only be carried out in a well planned and coordinated fashion. The Directors believe that forming alliance with experienced player is a way to secure success in such new ventures.

# STATEMENT OF BUSINESS OBJECTIVES

## Strategies for achieving the objectives

In order to facilitate the achievement of the above objectives, the Directors believe that the following are some practicable strategies:

1. Development of new products with application of advanced technology;
2. Maintenance of a strong research and development team;
3. Establishment of new production bases and the purchase of new equipment and facilities;
4. Expansion of sales and distribution network;
5. Marketing, promotion and brand building; and
6. Business collaborations and acquisitions.

## Proposed implementation plans

The detailed implementation plan is set out as follows:

### 1. Development of new products with application of advanced technology;

#### a. *New products to be applied in the existing business*

##### (i) Online monitoring system of fire prevention and fighting systems

The system integrates various advanced technologies, such as, geographical information system (“GIS”), global positioning system (“GPS”), remote sensing system (“RS”) through broadband internet multi-media information technology to monitor different automated fire alarm systems situated in different buildings. The system consists of multi-level networks containing intelligent distant inspections over fire prevention and fighting systems in various buildings, including intra-community, intra-city and intra-nation networks. In addition, the networks are linked with the 119 fire emergency centre via audio and visual information on site. The new system will be jointly developed with Fuzhou Research Institute. Fuzhou Research Institute will be responsible for performing feasibility studies, core technology development, formulating application programme and integration of hardware. The Group will be responsible for formulating the new product standard, enhancing the product functions, performing product testing, drafting production plan and applying production permit.

##### (ii) Intelligent power supply safety protection monitoring and control system

Power supply failures is one of the major causes of fire accidents and hazards in the PRC. To ensure safety in power supply and usage, this system intends to develop a new fire prevention and fighting system by adopting sensory transmission technology, computer technology and automated control technology on the power supply which contains intelligent monitoring and display of circuit

## STATEMENT OF BUSINESS OBJECTIVES

breakdowns, sending of timely messages and alarms, and cut off of power supplies when required. The system can replace fuses in home appliance with a better protection from latent fire hazards. The Directors believe that this product will have huge market potential. The new system will be jointly developed with Fuzhou Research Institute. Fuzhou Research Institute will be responsible for performing feasibility studies, core technology development and formulating application programme. The Group will be responsible for formulating the new product standard, performing product testing, drafting production plan and applying production permit.

(iii) Intelligent fire detector operated by CPUs

To further improve the technological level on fire detector, the Group has completed the development of a new model of intelligent fire detector by introducing the multi-sensing info-merging technology and fussy control logic operated by CPUs. The new product can greatly enhance the reliability and sensibility of a fire detector. The product, having multi-sensing data analytical functions, will substantially reduce the workload of the main control panel on information collection, flow and arrangement and increase the effectiveness and efficiency of the alarm system. The new product will be jointly developed with Shenyang Research Institute. Shenyang Research Institute will be responsible for performing the feasibility studies, core technology development and product testing. The Group will be responsible for the product standard testing, product function enhancement, formulating production plan and applying production permit. The Directors believe that such new intelligent fire detector, with its special technological feature, will have wide application in the PRC.

(iv) Crystal luminous emergency lighting system

The Group applies a new luminous material to replace the traditional incandescent lighting, fluorescent lighting and electro luminescence panel. The Directors believe that the crystal luminous materials have stronger light source, as the new coating technology enables such emergency lighting to generate light by condensation, reflection and refraction. In addition, the new emergency lighting has the characteristics of even spread of lighting, low consumption, small size, low voltage and long average working hours. The new product will be developed solely by the internal research and development team of the Group. The Directors believe that such new product is the first of its kind in the PRC and its overall technology is far ahead of its peers in the industry. The Directors also believe that such new lighting system has wide application in the PRC.

*b. New product lines and new types of services*

(i) Fire retardant materials

In respect of the fire retardant material market, the Group intends to manufacture and distribute the following types of products:

- Decorative fire retardant coatings;
- Steel structure fire retardant coatings; and
- Other fire retardant coatings.

## STATEMENT OF BUSINESS OBJECTIVES

### (ii) Fire service equipment

Since the Group has been accredited by the State as one of the qualified supplier of fire service equipment, the Group will take positive actions in developing strategic alliances with its local and overseas partners. At present, the Group has formed strategic alliances with Morita, Fuzhou Research Institute and Shenyang Research Institute and the Group expects to locate prospective partners in due course. By co-operating closely with its partners, the Group will have access into fire service equipment sector by serving as the distribution agency and manufacturer of fire service equipment. The Directors believe that the Group will be able to supply suitable fire service equipment to fire stations throughout the country. Currently, the fire service equipment intended to be provided by the Group include the followings:

- fire engines;
- fire hydrants;
- fire cannons;
- equipment and accessories for firemen; and
- other fire service equipment.

In February 2002, the Group entered into a letter of intent with Morita, one of the largest fire engine manufacturers in the world. Pursuant to such agreement, the Group has been appointed as the sole distributor of Morita in southern China to market Morita's fire engines to relevant fire stations. The parties are in the process of negotiation, the details of terms of the agreement such as consideration, minimum purchase requirements and delivery and payment have not yet been finalised as at the Latest Practicable Date. Upon finalisation of the details of terms, Morita and the Group will enter into a formal agreement and commence cooperation, for which the Directors expect to materialise in early October 2002. Both Morita and the Group expressed that an agency basis of cooperation is a starting point for both parties collaboration and they are looking forward to a higher level of cooperation, such as joint venture of manufacturing bases, in the future.

### (iii) Fire services installation project for specialised industries

Due to the distinctive natures of the transportation, forestry, mining and petrochemical industries, requirements for quality fire prevention and fighting systems are exceptionally high. Accordingly, the Group will provide highly customised fire prevention and fighting solutions to such kind of clientele. The Group intends to recruit experts in different industries to work with its research and development and installation project team to develop appropriate systems for different industries. The Directors believe that the competition in the industry specialised installation is comparatively low while demands are increasing; hence, such area represents a huge potential for the Group.

## 2. Enhancement of a strong research and development team;

Although the Group has been putting substantial efforts in the research and development, the Directors believe that should the Group desire to further expand its market share, research and development is the key for success and the Group's research and

## STATEMENT OF BUSINESS OBJECTIVES

development strength is yet to be improved. In order to strengthen the internal research and development capabilities, the Group intends to further expand the existing research and development team by establishing a research and development centre equipped with more advanced equipment and a laboratory specialised in upgrading the technological level of its products. The Group's research and development team will then be enlarged to approximately 30 people, who will be able to enhance and expedite the research of the fire prevention and fighting network, which is considered to be the future trend of the industry. In addition, the Directors believe that the enhanced research and development team will be able to constantly upgrade the functionality of fire safety equipment and hence its product life cycle. Apart from the internal aspect, the Group intends to continue and expand the scope of research and development efforts under cooperation of universities and science institutions. The Group expects that more such kind of institutions will become the Group's partners and the Group will be able to leverage on the partners capabilities. Such cooperation may be conducted in long term agreements with universal coverage or one-off assignments with a specific topic from time to time. Investment on the new research and development centre would amount to approximately HK\$10 million which will be funded by the proceeds of the Placing. The Directors believe that the new research and development centre will commence operation in the second half of 2004.

### **3. Establishment of new production bases and the purchase of new equipment and facilities;**

In view of the anticipated increase in sales of the Group, the Directors consider that the production plant in Fuzhou will not be able to meet future production needs. To increase the production capacity of the Group, a new production base is intended to be established in Fujian. The new production base will be equipped with advanced and automated production facilities and approximately HK\$16 million is budgeted for the acquisition. In addition, the new production base will also accommodate the production of new products as a result of the Group's research and development. The Company plans to acquire a parcel of land of approximately 10,000 sq.m. for the establishment of the new production base and the budget for the land acquisition is approximately HK\$10 million. The construction cost of the new production base is budgeted to be approximately HK\$4 million. Accordingly, the estimated total cost of the new production base is approximately HK\$30 million and production is expected to commence in the first half of 2004.

Since the Directors believe that Western China will become another important market for fire prevention and fighting products in the future, the Group will also set up another new production base in the Western part of China and the estimated total cost is HK\$20 million. Approximately HK\$8 million will be used for the acquisition of equipment and facilities and the remaining amounts of HK\$12 million will be used for the acquisition of land and the establishment of factory premises. The new production base will be established and commence operation to accommodate the expected expansion of sales of the Group's products in Western China in early 2005.

### **4. Expansion of sales and distribution network;**

The Group places great emphasis on building and expansion of its sales network as the Directors believe that the Group's business of Product Sales and Installation Services will have a better reach nationwide as quality and pricing become more competitive.



## STATEMENT OF BUSINESS OBJECTIVES

In addition, the Group also intends to introduce some of its products into the international market and preparation is currently underway to obtain international certifications. The following are the Group's strategy to enlarge its sales network:

- (i) Establishment of branch offices in medium and large provincial capitals in the PRC

Apart from its existing network of offices, the Directors intend to establish branch offices in medium and large provincial capitals in the PRC namely Shenyang (瀋陽), Shijiazong (石家莊), Xian (西安), Changsha (長沙), Wuhan (武漢), Hefei (合肥), Chengdu (成都), Chongqing (重慶), Wenzhou (溫州) and Guangzhou (廣州). These branch offices will facilitate the establishment of a nationwide distribution of the Group's products. In addition, the branch offices will also promote the Installation Services and Maintenance Services of the Group. The Directors believe that the establishment of branch offices will serve to develop local markets for the Group's products and services, commence brand name promotion and supervise distributors of the respective sales regions. The branch offices will also explore the Installation Services by collaborating with local contractors and project companies. The Directors believe that 10 branch offices, each with approximately 5 staff, will be established and commence operation by the second half of 2004 and the Group will have 23 branch offices by the end of 2004.

- (ii) Establishment of demonstration service centres in key regional markets including Beijing, Shanghai, Shenyang, Xian and Chengdu.

In order to further enhance its position as one of the dominant solution providers of fire prevention and fighting systems in the PRC, the Group plans to promote its products and services by means of public demonstration. Currently, the Group is operating a demonstration centre with Fuzhou Fire Services Department in the premises of Fuzhou Fire Services Station. The Directors intend to establish service centres to demonstrate the Group's branded products and services. The demonstration service centres will serve various functions including product display, agency negotiations, direct sales, customer service, project negotiations and fire prevention and fighting education. The first next demonstration service centre will be established in Shanghai by the first half of 2003 and the number of demonstration service centres will be increased to 5 (namely, Beijing (北京), Shanghai (上海), Shenyang (瀋陽), Xian (西安) and Chengdu (成都)) by the end of 2004. The long term objective is to expand the network of service centres nationwide by means of chain store participation, with a view to growing into the largest chain of service centres for fire prevention and fighting systems in the PRC.

### 5. Marketing, promotion and brand building

The Directors believe that a good reputation can strengthen the Group's ability to compete with other market participants and explore potential markets. The Group plans to strengthen its reputation through advertisements, formation of alliances with professional associations and academic institutions and participation in various trade shows and exhibitions. The Group intends to place advertisements in the industry's newspapers, magazines, television and websites, sponsor national community service activities relating to the promotion of fire prevention and fighting, participate in relevant academic seminars, product exchange conferences, industry exhibitions of the fire prevention and fighting systems and develop good relationship with the media in different regions of the country so as to procure positive reports of the Group from the press media.

## STATEMENT OF BUSINESS OBJECTIVES

### 6. Business collaborations and acquisitions

The Directors consider that potential business collaborations and acquisitions will intensify the growth of the Group. Accordingly, vertical and horizontal acquisition activities of the Group will run concurrently with other operational strategies of the Group.

- (i) Acquisitions of enterprises in the sector of fire service equipment and fire retardant materials

In line with the development of its product lines, the Group intends to look for opportunities to acquire manufacturing enterprises engaged in fire service equipment as well as fire retardant material products, so as to have a speedy foray into the production and manufacture of these sectors.

- (ii) Acquisitions of enterprises within similar product sector complementary to the Group

In order to enhance the competitiveness of the Group's existing products and increase its market share, the Group intends to acquire enterprises in the fire alarm equipment sector, which will help to expand the Group's sales network, upgrade its production scale, reduce its production costs and increase its market share.

# STATEMENT OF BUSINESS OBJECTIVES

Set out below is an outline timetable for the implementation plan:

## 1. Development of new products with application of advanced technology

Latest Practicable Date to	1st January, 2003 to 30th June, 2003	1st July, 2003 to 31st December, 2003	1st January, 2004 to 30th June, 2004	1st July, 2004 to 31st December, 2004
----------------------------------	--	---	--	---

### a. New products to be applied in the existing business

#### (i) Online monitoring system of fire prevention and fighting systems

- Finalise feasibility studies and networking outline	- Finalise networking hardware requirement and commence setting of software specification	- Finalise application programming and integrate hardware and software	- Finalise negotiation with bandworth providers and commence pilot testing	- Complete testing and launch of network
---	---	--	--	--

#### (ii) Intelligent power supply safety protection monitoring and control system

- Finalise feasibility studies and bill of materials	- Develop pilot samples of the product	- Start field experiment and commence negotiation with suppliers	- Apply production permit and start quality attestation	- Launch product
--	--	--	---	------------------

#### (iii) Intelligent fire detector operated by CPUs

- Finalise bill of materials	- Develop pilot samples of the product	- Apply production permit and start quality attestation	- Obtain quality certificate and plan for commercial production	- Commercial production and launch of product
------------------------------	--	---	---	---

#### (iv) Crystal luminous emergency lighting system

- Finalise bill of materials	- Develop pilot samples of the product	- Apply production permit and start quality attestation	- Obtain quality certificate and plan for commercial production	- Commercial production and launch of product
------------------------------	--	---	---	---

## STATEMENT OF BUSINESS OBJECTIVES

*b. New product lines and new types of services*

Latest Practicable Date to 31st December, 2002	1st January, 2003 to 30th June, 2003	1st July, 2003 to 31st December, 2003	1st January, 2004 to 30th June, 2004	1st July, 2004 to 31st December, 2004
(i) Fire retardant materials				
<ul style="list-style-type: none"> <li>- Perform feasibility studies and market research of the fire retardant material sector</li> </ul>	<ul style="list-style-type: none"> <li>- Identify potential companies manufacturing or supplying fire retardant material</li> </ul>	<ul style="list-style-type: none"> <li>- Negotiate with the targeted companies and pursue investment opportunities</li> </ul>	<ul style="list-style-type: none"> <li>- Expand to the fire retardant material sector by acquisition or alliances with the targeted companies</li> </ul>	<ul style="list-style-type: none"> <li>- Commence operation of the acquired companies or alliances</li> <li>- Pursue further investment opportunities</li> </ul>
(ii) Fire service equipment				
<ul style="list-style-type: none"> <li>- Perform feasibility studies and market research of the fire service equipment sector</li> </ul>	<ul style="list-style-type: none"> <li>- Identify potential companies manufacturing or supplying fire service equipment</li> </ul>	<ul style="list-style-type: none"> <li>- Negotiate with the targeted companies and pursue investment opportunities</li> </ul>	<ul style="list-style-type: none"> <li>- Expand to the fire service equipment sector by acquisition or alliances with the targeted companies</li> </ul>	<ul style="list-style-type: none"> <li>- Commence operation of the acquired companies or alliances</li> <li>- Pursue further investment opportunities</li> </ul>

# STATEMENT OF BUSINESS OBJECTIVES

Latest Practicable Date to 31st December, 2002	1st January, 2003 to 30th June, 2003	1st July, 2003 to 31st December, 2003	1st January, 2004 to 30th June, 2004	1st July, 2004 to 31st December, 2004
--	--	---	--	---

(iii) Fire services installation project for specialised industries

<ul style="list-style-type: none"> <li>- Perform feasibility studies and market research of the fire prevention and fighting systems installation for specialised industries</li> </ul>	<ul style="list-style-type: none"> <li>- Improve the existing equipment to perform specialised fire prevention and fighting systems installation</li> </ul>	<ul style="list-style-type: none"> <li>- Bid the specialised fire prevention and fighting systems installation projects</li> </ul>	<ul style="list-style-type: none"> <li>- Complete the fire prevention and fighting systems installation project for the specialised industry</li> </ul>	<ul style="list-style-type: none"> <li>- Continue the operation of specialised fire prevention and fighting systems installation projects</li> </ul>
	<ul style="list-style-type: none"> <li>- Recruit technical personnel to perform specialised fire prevention and fighting systems installation</li> </ul>	<ul style="list-style-type: none"> <li>- Commence the fire prevention and fighting systems installation project for one specialised industry</li> </ul>	<ul style="list-style-type: none"> <li>- Continue to bid the specialised fire prevention and fighting systems installation project</li> </ul>	

# STATEMENT OF BUSINESS OBJECTIVES

## 2. Enhancement of a strong research and development team

Latest Practicable Date to 31st December, 2002	1st January, 2003 to 30th June, 2003	1st July, 2003 to 31st December, 2003	1st January, 2004 to 30th June, 2004	1st July, 2004 to 31st December, 2004
<ul style="list-style-type: none"> <li>- Formulate plans and composition of research &amp; development center</li> </ul>	<ul style="list-style-type: none"> <li>- Commence construction of the research &amp; development center</li> </ul>	<ul style="list-style-type: none"> <li>- Construction in progress for the research &amp; development centre</li> </ul>	<ul style="list-style-type: none"> <li>- Completion of construction</li> </ul>	<ul style="list-style-type: none"> <li>- Commence operation of the research &amp; development centre</li> </ul>
<ul style="list-style-type: none"> <li>- Prepare and design the construction of the research &amp; development center</li> </ul>		<ul style="list-style-type: none"> <li>- Purchase equipment and facilities for the research &amp; development centre</li> </ul>	<ul style="list-style-type: none"> <li>- installation of equipment and facilities</li> </ul>	
<ul style="list-style-type: none"> <li>- Enter into co-operation agreement with scientific research organisations on the research of fire prevention and fighting technology</li> </ul>	<ul style="list-style-type: none"> <li>- Confirm the research &amp; development projects on fire prevention and technology (1 to 2 projects at one time)</li> </ul>	<ul style="list-style-type: none"> <li>- Commence the research work on one project on fire prevention and fighting technology</li> </ul>	<ul style="list-style-type: none"> <li>- Continue the research work of the project</li> </ul>	<ul style="list-style-type: none"> <li>- Complete the research work of the project</li> <li>- Commence the research work on another project on fire prevention and fighting technology</li> </ul>

# STATEMENT OF BUSINESS OBJECTIVES

## 3. Establishment of new production bases and the purchase of new equipment and facilities

Latest Practicable Date to 31st December, 2002	1st January, 2003 to 30th June, 2003	1st July, 2003 to 31st December, 2003	1st January, 2004 to 30th June, 2004	1st July, 2004 to 31st December, 2004
<b>Production base in Fujian</b>				
<ul style="list-style-type: none"> <li>- Formulate plan to build new production facilities</li> </ul>	<ul style="list-style-type: none"> <li>- Commence the preparation work and the design of the new production facilities</li> </ul>	<ul style="list-style-type: none"> <li>- Complete the construction of the new production facilities</li> </ul>	<ul style="list-style-type: none"> <li>- Commence mass production of the new production facilities</li> </ul>	<ul style="list-style-type: none"> <li>- same as last period</li> </ul>
<ul style="list-style-type: none"> <li>- Identify and confirm suitable location for the new production facilities</li> </ul>	<ul style="list-style-type: none"> <li>- Commence the construction of the new production facilities</li> </ul>	<ul style="list-style-type: none"> <li>- Install and complete the testing of new production equipment</li> </ul>		
	<ul style="list-style-type: none"> <li>- Initial payment for the purchase of new production equipment</li> </ul>	<ul style="list-style-type: none"> <li>- Commence trial production</li> </ul>		

# STATEMENT OF BUSINESS OBJECTIVES

Latest Practicable Date to	1st January, 2003 to 30th June, 2003	1st July, 2003 to 31st December, 2003	1st January, 2004 to 30th June, 2004	1st July, 2004 to 31st December, 2004
----------------------------------	--	---	--	---

**Production base in the western part of China**

- |  |   |
|--|---|
| <ul style="list-style-type: none"> <li>- Formulate plan to build other new production facilities</li> </ul>                  | <ul style="list-style-type: none"> <li>- Commence the preparation work and the design of the new production facilities</li> </ul>         |
| <ul style="list-style-type: none"> <li>- Identify and confirm suitable location for the new production facilities</li> </ul> | <ul style="list-style-type: none"> <li>- Formulate plan to purchase new production equipment for the new production facilities</li> </ul> |



# STATEMENT OF BUSINESS OBJECTIVES

## 4. Expansion of sales and distribution network

Latest Practicable Date to 31st December, 2002	1st January, 2003 to 30th June, 2003	1st July, 2003 to 31st December, 2003	1st January, 2004 to 30th June, 2004	1st July, 2004 to 31st December, 2004
<ul style="list-style-type: none"> <li>- Search for appropriate 5 sales offices in Shenyang, Shijiazhong, Xian, Wuhan and Chengdu of the PRC</li> </ul>	<ul style="list-style-type: none"> <li>- Decorate and purchase equipment for the 5 sales offices selected in Shenyang, Shijiazhong, Xian, Wuhan and Chengdu of the PRC</li> </ul>	<ul style="list-style-type: none"> <li>- Commence the operations of the 5 new sales offices in Shenyang, Shijiazhong, Xian, Wuhan and Chengdu of the PRC</li> </ul>	<ul style="list-style-type: none"> <li>- Same as last period</li> </ul>	<ul style="list-style-type: none"> <li>- Same as last period</li> </ul>
	<ul style="list-style-type: none"> <li>- Search for appropriate 5 sales offices in Hefei, Changsha, Chongqing, Wenzhou and Guangzhou</li> </ul>	<ul style="list-style-type: none"> <li>- Decorate and purchase equipment for the 5 sales offices selected in Hefei, Changsha, Chongqing, Wenzhou and Guangzhou</li> </ul>	<ul style="list-style-type: none"> <li>- Commence the operations of the 5 new sales office in Hefei, Changsha, Chongqing, Wenzhou and Guangzhou</li> </ul>	<ul style="list-style-type: none"> <li>- Same as last period</li> </ul>
<ul style="list-style-type: none"> <li>- Decorate the existing sales offices, purchase new office equipment and hire experienced sales personnel</li> </ul>	<ul style="list-style-type: none"> <li>- Decorate another 13 existing sales offices, purchase new office equipment and hire experienced sales personnel</li> </ul>	<ul style="list-style-type: none"> <li>- Continue operation of the improved sales offices and expand sales of the respective offices</li> </ul>	<ul style="list-style-type: none"> <li>- Same as last period</li> </ul>	<ul style="list-style-type: none"> <li>- Same as last period</li> </ul>
<ul style="list-style-type: none"> <li>- Formulate plan to establish the display service centre in Shanghai</li> </ul>	<ul style="list-style-type: none"> <li>- Commence operations of the display service centre in Shanghai</li> </ul>	<ul style="list-style-type: none"> <li>- Continue operation of the display service centre in Shanghai</li> </ul>	<ul style="list-style-type: none"> <li>- Same as last period</li> </ul>	<ul style="list-style-type: none"> <li>- Same as last period</li> </ul>

## STATEMENT OF BUSINESS OBJECTIVES

Latest Practicable Date to 31st December, 2002	1st January, 2003 to 30th June, 2003	1st July, 2003 to 31st December, 2003	1st January, 2004 to 30th June, 2004	1st July, 2004 to 31st December, 2004
	<ul style="list-style-type: none"> <li>- Search for appropriate display service centres in Beijing and Shenyang of the PRC</li> </ul>	<ul style="list-style-type: none"> <li>- Decorate the display service centres in Beijing and Shenyang, purchase new equipment and hire experienced sales personnel</li> </ul>	<ul style="list-style-type: none"> <li>- Commence operation of the display service centers in Beijing and Shenyang</li> </ul>	<ul style="list-style-type: none"> <li>- Same as last period</li> </ul>
		<ul style="list-style-type: none"> <li>- Search for appropriate display service centres in Xian and Chengdu of the PRC</li> </ul>	<ul style="list-style-type: none"> <li>- Decorate the display service centres in Xian and Chengdu purchase new equipment and hire experienced sales personnel</li> </ul>	<ul style="list-style-type: none"> <li>- Commence operation of the display service centres in Xian and Chengdu</li> </ul>

# STATEMENT OF BUSINESS OBJECTIVES

## 5. Marketing, promotion and brand building

Latest Practicable Date to 31st December, 2002	1st January, 2003 to 30th June, 2003	1st July, 2003 to 31st December, 2003	1st January, 2004 to 30th June, 2004	1st July, 2004 to 31st December, 2004
<ul style="list-style-type: none"> <li>- Design marketing plans for the principal products of the Group</li> </ul>	<ul style="list-style-type: none"> <li>- Launch television or radio commercials in the PRC to promote the brand name recognition of the Group's products</li> </ul>	<ul style="list-style-type: none"> <li>- Evaluate the effects of the previous marketing plans</li> </ul>	<ul style="list-style-type: none"> <li>- Launch new promotional activities (such as television commercials) for the principal products of the Group</li> </ul>	<ul style="list-style-type: none"> <li>- Continue to design new promotional activities for the principal products of the Group</li> </ul>
<ul style="list-style-type: none"> <li>- Advertise the Group's products on journals and magazines</li> </ul>	<ul style="list-style-type: none"> <li>- Same as last period</li> </ul>	<ul style="list-style-type: none"> <li>- Same as last period</li> </ul>	<ul style="list-style-type: none"> <li>- Same as last period</li> </ul>	<ul style="list-style-type: none"> <li>- Same as last period</li> </ul>
<ul style="list-style-type: none"> <li>- Organise &amp; attend conferences and seminars relating to fire prevention and fighting technology</li> </ul>	<ul style="list-style-type: none"> <li>- Same as last period</li> </ul>	<ul style="list-style-type: none"> <li>- Same as last period</li> </ul>	<ul style="list-style-type: none"> <li>- Same as last period</li> </ul>	<ul style="list-style-type: none"> <li>- Same as last period</li> </ul>

# STATEMENT OF BUSINESS OBJECTIVES

## 6. Business collaborations and acquisitions

(i) *Acquisitions of enterprises in the sector of fire service equipment and fire retardant materials*

**Latest  
Practicable**

Date to 31st December, 2002	1st January, 2003 to 30th June, 2003	1st July, 2003 to 31st December, 2003	1st January, 2004 to 30th June, 2004	1st July, 2004 to 31st December, 2004
-----------------------------------	--	---	--	---

- Identify potential manufacturing enterprises in the PRC which engaged in the sector of fire service equipment and fire retardant materials and acquire the companies which reach mutual agreement with the Group.

(ii) *Acquisitions of enterprises within similar product sector complementary to the Group*

**Latest  
Practicable**

Date to 31st December, 2002	1st January, 2003 to 30th June, 2003	1st July, 2003 to 31st December, 2003	1st January, 2004 to 30th June, 2004	1st July, 2004 to 31st December, 2004
-----------------------------------	--	---	--	---

- Identify potential enterprises in the PRC, Hong Kong, Singapore and Japan which engaged in the similar product sector complementary to the Group;
- Explore and evaluate the opportunities to establish co-operation arrangement, collaboration or alliances with the companies identified;
- Negotiate with the management of the companies identified and develop collaboration or alliances or acquisitions with the companies identified.

As at the Latest Practicable Date, the Group had a total of 529 employees and following its implementation plans, the Directors expect that the total number of employees of the Group will be as follows:

	As at the Latest Practicable Date	As at 31st December, 2002	As at 30th June, 2003	As at 31st December, 2003	As at 30th June, 2004	As at 31st December, 2004
Sales and marketing	93	100	105	110	130	130
Fire services installation (including maintenance services)	21	25	30	30	35	35
Production (including quality control and assurance)	369	450	450	460	660	680
Research and development	12	15	15	25	27	27
Finance and administration	34	38	42	42	50	50
	<u>529</u>	<u>628</u>	<u>642</u>	<u>667</u>	<u>902</u>	<u>922</u>

# STATEMENT OF BUSINESS OBJECTIVES

## USE OF PROCEEDS

The Directors believe that the net proceeds from the issue of New Shares under the Placing will strengthen the Group's capital base and improve its gearing position. The net proceeds will also assist the Group in research and development, corporate and business development, service enhancement, marketing and brand building.

The net proceeds from the Placing of New Shares, after deduction of underwriting fees and estimated expenses payable by the Company in relation to the Placing, are estimated to be approximately HK\$137.6 million. The Directors currently intend to use the net proceeds from the issue of New Shares under the Placing as follows:

- approximately HK\$20.0 million for the development of new products, obtain production permit as well as launching of new products in the market;
- approximately HK\$10.0 million for the establishment of a research and development centre replacing the existing research and development department and equipped with more advanced facilities. The research and development team will be enlarged and will undertake more research projects on the development of fire prevention and fighting technology;
- approximately HK\$50.0 million for the establishment of new production bases, HK\$20.0 million and HK\$30.0 million will be used to establish a new production base in Western part of China and Fujian respectively;
- approximately HK\$20.0 million for the enhancement and development of the Group's sales and distribution network throughout the PRC amongst which about HK\$10.0 million will be used for the establishment of 10 additional branches, about HK\$5.0 million will be used for the setting up of 5 new demonstration service centres and about HK\$5.0 million will be used for the improvement of the existing 16 branch offices;
- approximately HK\$10.0 million for marketing, promotion and brand building activities to support bidding for installation projects in provinces other than Fujian;
- approximately HK\$20.0 million for business collaboration and acquisition of other related businesses and strategic investments amongst which about HK\$10.0 million is earmarked for the acquisition of enterprises in the sector of fire service equipment and fire retardant materials and about HK\$10.0 million is earmarked for the acquisition of enterprises engaged in the manufacturing of sensors and fire alarm system complimentary to the Group; and
- the remaining balance of HK\$7.6 million is expected to be used as general working capital of the Group amongst which about HK\$3.0 million is earmarked for the additional working capital required to manufacture new products, about HK\$2.6 million is earmarked for the additional working capital for the sales of fire service equipment, fire retardant materials and the business of fire service installation projects and about HK\$2.0 million is earmarked for maintaining the day-to-day operation of the Group.

## STATEMENT OF BUSINESS OBJECTIVES

The Directors intend to apply the net proceeds from the issue of New Shares under the Placing according to the following time schedule:

	<b>From the Latest Practicable Date to 31st December, ending 2002</b>	<b>Six months Six months ending 30th December, ending June, 2003</b>	<b>Six months Six months ending 30th December, ending 2003</b>	<b>Six months Six months ending 31st December, June, 2004</b>	<b>Six months ending 31st December, 2004</b>	<b>Total</b>
	<i>HK\$ million</i>	<i>HK\$ million</i>	<i>HK\$ million</i>	<i>HK\$ million</i>	<i>HK\$ million</i>	<i>HK\$ million</i>
Development of new products	7	8	1	1	3	20
Establishment of a research and development centre	2	4	3	1	–	10
Establishment of new production bases and the purchase of new equipment and facilities	5	15	10	15	5	50
Expansion of sales and distribution network	8	8	2	2	–	20
Marketing, promotion and brand building	4	3	1	1	1	10
	<u>26</u>	<u>38</u>	<u>17</u>	<u>20</u>	<u>9</u>	110
Business collaborations and acquisitions ( <i>Note</i> )						<u>20</u>
						<u>130</u>

*Note:* The use of proceeds in such connection is dependent on the opportunity available and negotiation outcome. The Directors believe that it is inappropriate to earmark specific amount in each of the periods.

If the Over-allotment Option is exercised in full, the Company will receive additional net proceeds of approximately HK\$29.0 million which the Directors intend to allocate as follows:

- an additional sum of approximately HK\$7.0 million will be allocated for the continuing marketing, promotion and brand building activities which will enable the Group to intensify its marketing programmes;
- an additional sum of approximately HK\$20.0 million will be used for the business collaboration and acquisition of other related businesses and strategic investments amongst which about HK\$10.0 million is earmarked for the acquisition of enterprises in the sector of fire service equipment and fire retardant materials and about HK\$10.0 million is earmarked for the acquisition of enterprises engaged in the manufacturing of sensors and fire alarm system complimentary to the Group. The Directors consider that the additional funds will enhance the Group's position in the acquisition of such potential enterprises in the industry; and
- an additional sum of HK\$2.0 million will be used as general working capital to maintain the day-to-day operation of the Group.

## STATEMENT OF BUSINESS OBJECTIVES

The Directors consider that if the Over-allotment Option is not exercised, there would not be any material adverse impact on the ability or resources of the Group in relation to the implementation of its business plan as stated under the section headed “Statement of Business Objectives” in this prospectus.

To the extent that the net proceeds from the issue of New Shares under the Placing are not immediately applied for the above purposes, it is the present intention of the Directors that such net proceeds will be placed on short-term, interest-bearing deposits with licensed banks or other financial institutions in Hong Kong.

In the event that there is any material modification to the use of proceeds as stated above, the Company will issue an announcement.

# DIRECTORS, SENIOR MANAGEMENT AND EMPLOYEES

## DIRECTORS

### Executive Directors

**Mr. JIANG Xiong** (江雄), aged 34, is the Chairman, chief executive officer and executive Director of the Group. He is responsible for the strategic planning and the overall development of the Group and joined the Group in January 1994. He has over 8 years of experience in the fire services and maintenance industry in the PRC. In April 1996, he was awarded the title “Fuzhou Outstanding Entrepreneur” (福州市優秀私營企業家). In May 1996, Mr. Jiang was awarded one of the “Ten Most Outstanding Youths in Fuzhou” and in November 1997 he was appointed as “member of the Ninth Standing Committee of Fuzhou City People’s Political Consultative Conference” (中國人民政治協商會議第九屆福建省福州市常務委員會委員). In May 1999, he was given the award of “Fujian Outstanding Entrepreneur” (福建省優秀青年企業家). In November 2001, he was also appointed as Vice Secretary-General of Fire Committee of International Police Foundation (世界警察基金會消防行業委員會副秘書長), a non-profit organisation for the promotion of police goodwill and development of police science. Mr. Jiang is a qualified engineer in the PRC.

**Mr. JIANG Qing** (江清), aged 37, is an executive Director and chief operating officer of the Group. He joined the Group in April 1995 and has over 9 years of experience in the building construction industry and fire prevention and fighting systems installation. Prior to joining the Group in April 1995, Mr. Jiang was an assistant executive of Fujian Construction and Development Limited (福建省建設發展總公司), a company engaged in property development, from February 1993 to April 1995 and he was mainly responsible for the management and administration for construction projects. Mr. Jiang received the professional certificate from Fujian Technical Institute of Construction (福建建築高等專科學校) in September 2000 and is a qualified engineer in the PRC. He is responsible for the corporate management and overall operation of the Group. He is the elder brother of Mr. Jiang Xiong.

**Mr. CHEN Shu Quan** (陳樹泉), aged 57, is an executive Director and is responsible for the overall administration of the Group. Mr. Chen joined the Group in January 1997 and has over 10 years of administration and management experience in Fujian governmental entities. Before joining the Group, he was the vice director (副局長) of Departmental Affairs Administration Office of Fujian Provincial Government (福建省政府機關事務管理局省政府辦公廳) from 1986 to 1997 and was mainly responsible for the planning, management and administration affairs of government properties.

### Independent non-executive Directors

**Mr. LIU Shi Pu** (劉式浦), aged 67, is an independent non-executive Director. Mr. Liu has over 40 years of working experience in the Ministry of Public Security and worked for the Public Security Bureau of Lou Yang City (洛陽市) and He Nan Province (河南省), during the years 1952 to 1985. During the years 1985 and 1990, he was appointed as the Vice Chancellor of Public Security Bureau of He Nan Province (河南省公安廳副廳長). From 1991 to 1993, he was promoted as the Office Supervisor of the Ministry of Public Security of the PRC (中華人民共和國公安部辦公廳主任). In 1993, Mr. Liu was appointed as the Chairman of Fire Prevention and Fighting Bureau of the Ministry of Public Security of the PRC (中華人民共和國公安部消防局局長(少將)). In February 1996, he retired from his position. From August 1997 to September 2001, Mr. Liu was the Vice-chairman of General Affairs of the PRC Fire Prevention and Fighting Association (中華人民共和國消防協會常務副理事長). He was appointed as a director of the Company in May 2002. Mr. Liu does not hold position in any other company, apart from being an independent non-executive director of the Company.



## DIRECTORS, SENIOR MANAGEMENT AND EMPLOYEES

**Mr. WONG Hon Sum** (黃漢森), aged 44, is an independent non-executive Director and is a certified public accountant practising in Hong Kong. He holds a bachelor degree in accounting from the Hong Kong Polytechnic University. He has over 18 years of finance and accounting experience in Hong Kong. Mr. Wong is a fellow member of both Hong Kong Society of Accountants and The Chartered Association of Certified Accountants. Mr. Wong is also an associate of The Taxation Institute of Hong Kong and a member of Hong Kong Securities Institute. He was appointed as a director of the Company in May 2002. Mr. Wong is the director of Jovian Communications Group Limited which is engaged in the financial communication business. Mr. Wong is also the independent non-executive director of Interchina Holdings Company Limited and non-executive director of Euro-Asia Agricultural (Holdings) Company Limited.

### SENIOR MANAGEMENT

**Mr. XIAO Wen Ming** (肖文明), aged 63, is the chief engineer of the Group. Mr. Xiao graduated from Tsing Hwa University (清華大學) with a bachelor degree in mechanical engineering. Prior to joining the Group, he worked as a senior engineer (research level) (研究員級高級工程師) for China Atomic Research Institute (中國原子能科學研究院) from 1964 to 1999. Mr. Xiao joined the Group in February 1999 and is a qualified engineer (senior research level) (研究員級高級工程師) on fire prevention and fighting equipment in the PRC. Mr. Xiao is responsible for the overall management of the Group's fire prevention and fighting systems installation project.

**Mr. CHONG Ping** (叢平), aged 44, is the senior engineer of the Group. Mr. Chong graduated from Shenyang Industrial Institute (沈陽工業學院) with a bachelor degree in electrical engineering. Prior to joining the Group, he was a senior engineer (professor and research level) (教授研究員級高級工程師) for Liaoning Electrical Research Institute (遼寧省電子研究設計院) from 1982 to 1993 and visiting senior engineer for Denmark Technology University (丹麥技術大學) from 1993 to 1994. He was also the assistant manager at Shenyang Xing He Electronics Company Limited (沈陽星河電子有限公司) from 1995 to 1997. Mr. Chong joined the Group in April 1997 and is primarily responsible for the Group's product research and development.

**Mr. LIN Dong Hao** (林東豪), aged 28, is an engineer of the Group. He graduated from 東北重型機械學校 with a bachelor degree in Computer Engineering. He also holds a master's degree in Computer Application and a doctorate in Computer Science and Technology from Zhejiang University (浙江大學). Mr. Lin has over 3 years of experience in project management in the PRC when he was pursuing his doctorate at Zhejiang University (浙江大學). Mr. Lin joined the Group in April 2000 and is responsible for the technological development of the Group's products.

**Mr. LI Jin** (李謹), aged 47, is the general manager of the Group's fire prevention and fighting systems installation division. Mr. Li has over 20 years of experience in working for the fire services department of Fujian Province from 1974 to 2001. He retired from the fire services department of Fujian Province in 2001. He was also awarded Third Class Honour (三等功) for his contribution when he served in the fire services department in 1999. He joined the Group in May 2001 and is responsible for the supervision of the Group's fire prevention and fighting systems installation project. Mr. Li is a qualified engineer in the PRC.

### COMPANY SECRETARY AND QUALIFIED ACCOUNTANT

**Mr. CHAN Siu Tat**, aged 32, joined the Company in April 2002 and was appointed as the Company Secretary and Qualified Accountant of the Group in May 2002. Prior to joining the Group, Mr. Chan is the financial controller of a trading and manufacturing group, Milagros

## DIRECTORS, SENIOR MANAGEMENT AND EMPLOYEES

Corporation Limited, in which he is also a deputy general manager of its PRC manufacturing base. Prior to that, Mr. Chan had around five years auditing experience with an international accountants firm. Mr. Chan graduated from The Hong Kong University of Science and Technology with a major in Accounting. He is an associate member of Hong Kong Society of Accountants.

### COMPLIANCE OFFICER

Being a compliance officer, Mr. Jiang Qing will be advising on and assisting the board of Directors in implementing procedures to ensure that the Group complies with the GEM Listing Rules and other relevant laws and regulations applicable to the Company and responding promptly and efficiently to all enquiries directed at the Group by the Stock Exchange.

### AUDIT COMMITTEE

The Group established an audit committee on 22nd May, 2002 with written terms of reference in compliance with the requirements as set out in rules 5.23 and 5.24 of the GEM Listing Rules. The primary duties of the audit committee are to review and supervise the financial reporting process and internal control system of the Group and provide advice and comments to the board of Directors.

The following sets out the members of the Group's audit committee:

<b>Name</b>	<b>Position in the audit committee</b>	<b>Position in the board of Directors</b>
Mr. LIU Shi Pu	member	independent non-executive Director
Mr. WONG Hon Sum	chairman	independent non-executive Director

### STAFF

Apart from the Directors and senior management of the Group as mentioned above, as at 31st July, 2002, the Group employed a total of 529 employees. A breakdown of the number of employees by their duties is as follows:

	<b>the PRC</b>	<b>Hong Kong</b>	<b>Total</b>
Sales and marketing	93	–	93
Fire services installation (including maintenance services)	21	–	21
Production (including quality control and assurance)	369	–	369
Research and development	12	–	12
Finance and administration	32	2	34
Total	<u>527</u>	<u>2</u>	<u>529</u>

# **DIRECTORS, SENIOR MANAGEMENT AND EMPLOYEES**

## **THE GROUP'S RELATIONSHIP WITH STAFF**

The Group has not, in the past, experienced any significant disruption of its operations due to any major labour disputes. The Directors consider that the Group has a reasonably good relationship with its staff.

## **DIRECTORS' REMUNERATION POLICY**

An aggregate of approximately RMB193,000 was paid to the executive Directors as remuneration for the two years ended 31st December, 2001.

Each of Mr. Jiang Xiong, Mr. Jiang Qing and Mr. Chen Shu Quan, being all the executive Directors, has entered into a service agreement with the Company for a term of three years with a fixed term of one year. Either party to the service agreement shall be entitled to terminate the service agreement by giving to the other a notice in writing with a notice period of not less than 6 calendar months provided that such notice period shall not expire at any time during the fixed term. The service agreement will take effect from the Listing Date. Each of the executive Directors will receive a salary subject to an annual review. In addition, the executive Directors are entitled to a discretionary bonus at the absolute discretion of the board of Directors and such bonus shall be not more than 10 per cent. of the audited consolidated net profit after taxation and minority interests but before extraordinary and exceptional items of the Group for that financial year.

Under the present arrangement, the aggregate of the executive Directors' remuneration in cash and in kind for the year ending 31st December, 2002 is estimated to be about HK\$700,000. Further details of the terms of the above service agreement are set out in the paragraph headed "Particulars of service agreements" in the section headed "Further information about directors, senior management and staff" in Appendix IV to this prospectus.

## **PENSION SCHEME**

Currently, the Group's PRC employees have all enrolled in the mandatory central provision scheme operated by the PRC Government. The Group is required to provide retirement benefit to all its PRC employees pursuant to Provisional Regulations on Payment of Social Insurance Fee in Fujian (福建省社會保險費徵繳辦法) which became a mandatory obligation with effect from 1st January, 2001. According to such regulation, the Group's contribution on the pension insurance is equivalent to 18% of the total salary of its full time employees for 2002 and 19% for 2001. The Group's contribution for the year ended 31st December, 2001 and for the seven months ended 31st July, 2002 were about RMB2.4 million and RMB1.0 million respectively.

In accordance with the relevant mandatory provident fund laws and regulations of Hong Kong, the Group contributes a monthly amount to a professionally managed fund equivalent to 5% of the total salary of its full time employees (up to a maximum of HK\$1,000 for each employee). Each employee in Hong Kong is required to contribute 5% of his or her total salary to the scheme and may elect to make voluntary contributions.

## **SHARE OPTION SCHEME**

The Company has conditionally adopted the Share Option Scheme whereby employees of the Group, including executive Directors, may be granted options to acquire Shares. The Directors believe that the Share Option Scheme will assist in the recruitment and retention of high calibre executives and employees. The principal terms of the Share Option Scheme are set out in the paragraph headed "Share Option Scheme" under the section headed "Further information about directors, senior management at staff" in Appendix IV to this prospectus.

# **SUBSTANTIAL SHAREHOLDER, INITIAL MANAGEMENT SHAREHOLDER, SIGNIFICANT SHAREHOLDER AND OTHER SHAREHOLDERS**

## **SUBSTANTIAL SHAREHOLDER**

So far as the Directors are aware, immediately following the completion of the Placing and assuming that the Over-allotment Option is not exercised and without taking into account any Shares which may fall to be issued pursuant to the exercise of any options under the Share Option Scheme and the Shares which may be taken up under the Placing, the following person will be, directly or indirectly, entitled to exercise 10 per cent. or more of the voting power at the general meetings of the Company, or otherwise interested in 10 per cent. or more of the issued share capital of the Company and accordingly regarded as a Substantial Shareholder under the GEM Listing Rules:

<b>Name</b>	<b>Number of Shares</b>	<b>Approximate percentage of holding (%)</b>
Mr. Jiang Xiong	1,281,600,000	64.08%

Assuming the Over-allotment Option is exercised in full, immediately following the completion of the Placing, the interests of the above substantial shareholder in the share capital of the Company, represent approximately 61.76% of the issued share capital of the Company.

## **INITIAL MANAGEMENT SHAREHOLDER**

So far as the Directors are aware, immediately following the completion of the Placing and assuming that the Over-allotment Option is not exercised and without taking into account any Shares which may fall to be issued pursuant to the exercise of any options under the Share Option Scheme and the Shares which may be taken up under the Placing, the following shareholder will be entitled to exercise or control the exercise of 5 per cent. or more of the voting power at general meetings of the Company and who is able, as a practical matter, to direct or influence the management of the Company and accordingly regarded as an Initial Management Shareholder under the GEM Listing Rules:

<b>Name</b>	<b>Number of Shares</b>	<b>Approximate percentage of holding (%)</b>
Mr. Jiang Xiong	1,281,600,000	64.08%

## **SIGNIFICANT SHAREHOLDER**

So far as the Directors are aware, immediately following the completion of the Placing and assuming that the Over-allotment Option is not exercised and without taking into account any Shares which may fall to be issued pursuant to the exercise of any options under the Share Option Scheme and the Shares which may be taken up under the Placing, apart from the Initial Management Shareholder referred to above, the following shareholder is entitled to exercise or control the

## SUBSTANTIAL SHAREHOLDER, INITIAL MANAGEMENT SHAREHOLDER, SIGNIFICANT SHAREHOLDER AND OTHER SHAREHOLDERS

exercise of 5% or more of the voting power at the general meetings of the Company and accordingly regarded as Significant Shareholder under the GEM Listing Rules:

Name	Number of Shares	Approximate percentage of holding (%)
Cantus	160,000,000	8.00
Aria ( <i>Note</i> )	160,000,000	8.00

*Note:* The 160,000,000 Shares are indirectly held by Aria via its interests in its wholly-owned subsidiary, Cantus. Aria has given an undertaking to the Company, CPY, CPY International (for and on behalf of the Underwriters) and the Stock Exchange, details of which are set out in the paragraph headed "Further undertakings" in this section.

### OTHER SHAREHOLDERS

So far as the Directors are aware, immediately following the completion of the Placing and assuming that the Over-allotment Option is not exercised and without taking into account any Shares which may fall to be issued pursuant to the exercise of any options under the Share Option Scheme and the Shares which may be taken up under the Placing, apart from the Initial Management Shareholder and the Significant Shareholder referred to above, the following shareholders agree to restrictions on the disposal of their Shares during the 6 months period after the Listing Date:

Name	Number of Shares	Approximate percentage of holding (%)
YMW	35,040,000	1.75
Morita	23,360,000	1.17

### UNDERTAKINGS

The Initial Management Shareholder has undertaken to the Company, CPY, CPY International (for and on behalf of the Underwriters) and the Stock Exchange that he will:

- (i) place in escrow, with an escrow agent on such terms as are acceptable to the Stock Exchange, all his Relevant Securities in the Company during the Lock-up Period;
- (ii) save for the exercise of the Over-allotment Option and the circumstances provided by Rule 13.18 of the GEM Listing Rules, during the Lock-up Period, not dispose of (nor enter into any agreement to dispose of) nor permit the registered holder to dispose of (or enter into any agreement to dispose of) any of his direct or indirect interest in the Relevant Securities of the Company; and
- (iii) comply with Rule 13.19 of the GEM Listing Rules which requires that in the event that if he pledges or charges any direct or any indirect interest in the Relevant Securities of the Company under Rule 13.18(1) of the GEM Listing Rules or pursuant to any

## **SUBSTANTIAL SHAREHOLDER, INITIAL MANAGEMENT SHAREHOLDER, SIGNIFICANT SHAREHOLDER AND OTHER SHAREHOLDERS**

right or waiver granted by the Stock Exchange pursuant to Rule 13.18(4) of the GEM Listing Rules, at any time during the Lock-up Period, he must inform the Company immediately thereafter, disclosing the details specified in Rule 17.43(1) to (4) of the GEM Listing Rules; and having pledged or charged any interest in the Relevant Securities of the Company, he must inform the Company immediately in the event that he becomes aware that the pledgee or chargee has disposed of or intends to dispose of such interest and of the number of securities affected.

Each of Cantus, YMW and Morita has undertaken to the Company, CPY, CPY International (for and on behalf of the Underwriters) and the Stock Exchange that it will:

- (i) place in escrow, with an escrow agent on such terms as are acceptable to the Stock Exchange, all its Relevant Securities in the Company during the 6 month period from the Listing Date (“6 Month Period”);
- (ii) save for the exercise of the Over-allotment Option and the circumstances provided by Rule 13.18 of the GEM Listing Rules, during the 6 Month Period, not dispose of (nor enter into any agreement to dispose of) nor permit the registered holder to dispose of (or enter into any agreement to dispose of) any of its direct or indirect interest in the Relevant Securities of the Company; and
- (iii) comply with Rule 13.19 of the GEM Listing Rules which requires that in the event that it pledges or charges any direct or any indirect interest in the Relevant Securities of the Company under Rule 13.18(1) of the GEM Listing Rules or pursuant to any right or waiver granted by the Stock Exchange pursuant to Rule 13.18(4) of the GEM Listing Rules, at any time during the 6 Month Period, it must inform the Company immediately thereafter, disclosing the details specified in Rule 17.43(1) to (4) of the GEM Listing Rules; and having pledged or charged any interest in the Relevant Securities of the Company, it must inform the Company immediately in the event that it becomes aware that the pledgee or chargee has disposed of or intends to dispose of such interest and of the number of securities affected.

Immediately following the completion of the Placing and assuming that the Over-allotment Option is not exercised, the percentage of Shares to be held by the public will be approximately 25 per cent. If the Over-allotment Option is exercised in full, the percentage of Shares to be held by the public will be approximately 27.71 per cent.

### **FURTHER UNDERTAKINGS**

In addition to the above undertakings,

- (i) Aria has given an undertaking to the Company, CPY, CPY International (for and on behalf of the Underwriters) and the Stock Exchange that it will not, during the 6 Month Period, dispose of (or enter into any agreement to dispose of) any of its direct or indirect interest in the 1 ordinary share of US\$1.00 each in the capital of Cantus; and

## **SUBSTANTIAL SHAREHOLDER, INITIAL MANAGEMENT SHAREHOLDER, SIGNIFICANT SHAREHOLDER AND OTHER SHAREHOLDERS**

- (ii) each of CLSA Private Equity Management Limited and Yamaichi Hands-on Associates Inc. has given an undertaking to the Company, CPY, CPY International (for and on behalf of the Underwriters) and the Stock Exchange that during the 6 Month Period, it will not distribute in specie and/or dispose of the 160,000,000 and 35,040,000 Shares held by Cantus and YMW respectively to the investors of Cantus and YMW or any other persons; and
- (iii) Yamaichi Hands-on Associates Inc. has also given an undertaking to the Company, CPY, CPY International (for and on behalf of the Underwriters) and the Stock Exchange that during the 6 Month Period, it will not distribute the shares of YMW and the assets held by YMW to the investors of YMW respectively or any other persons.

# SHARE CAPITAL

The authorised and issued share capital of the Company are as follows:

HK\$

*Authorised:*

<u>10,000,000,000</u>	Shares	<u>100,000,000</u>
-----------------------	--------	--------------------

*Issued and to be issued, fully paid or credited as fully paid:*

1,600,000,000	Shares in issue	16,000,000
<u>400,000,000</u>	Shares to be issued under the Placing	<u>4,000,000</u>
<u>2,000,000,000</u>	Shares	<u>20,000,000</u>

The minimum level of public float to be maintained by the Company at all times after the listing of the Shares on GEM under the GEM Listing Rules, is 25% of the share capital of the Company in issue from time to time.

*Notes:*

## **Assumptions**

The above table assumes that the Placing becomes unconditional.

It takes no account of any Shares which may be issued under the Over-allotment Option or pursuant to the exercise of options which may be granted under the Share Option Scheme or of any Shares which may be allotted and issued or purchased by the Company pursuant to the general mandates for the allotment and issue or purchase of Shares granted to the Directors as described below.

## **Ranking**

The Placing Shares and the Shares to be issued as stated herein will rank pari passu with all other Shares now in issue. In particular, the Placing Shares will rank in full for all dividends and other distributions declared, paid or made on the Shares after the date of this prospectus.

## **Share Option Scheme**

The Company has conditionally adopted the Share Option Scheme, the principal terms of which are summarised in the paragraph headed "Share Option Scheme" under the section headed "Further information about directors, senior management and staff" in Appendix IV to this prospectus, under which the Company may grant options to subscribe for Shares under the terms of the Share Option Scheme to full time employees including any executive and non-executive directors of any members of the Group.

## **General mandate to allot and issue Shares**

Conditional on the Placing becoming unconditional, the Directors have been granted a general unconditional mandate to allot, issue and deal with Shares with a total nominal value of not more than the sum of:

1. 20 per cent. of the total nominal value of the share capital of the Company in issue immediately after the completion of the Placing and if applicable, which may be issued pursuant to the exercise of the Over-allotment Option; and
2. the total nominal value of the share capital of the Company purchased by the Company (if any) pursuant to the general mandate for the repurchase of Shares granted to the Directors referred to below.



## SHARE CAPITAL

The Directors may, in addition to Shares which they are authorised to issue under the above mandate, allot, issue and deal with Shares under a rights issue, scrip dividend scheme or similar arrangement or Shares to be issued upon the exercise of options granted under the Share Option Scheme.

This mandate will expire:

- at the end of the Company’s next annual general meeting; or
- at the end of the period within which the Company is required by any applicable laws or the Articles to hold its next annual general meeting; or
- when varied, revoked or renewed by an ordinary resolution of the shareholders of the Company in general meeting;

whichever occurs first.

For further details of this general mandate, see the sub-paragraph headed “Written resolutions of the sole shareholder of the Company passed on 12th July, 2002 and 20th September, 2002” in the section headed “Further information about the Company” in Appendix IV to this prospectus.

### **General mandate to repurchase Shares**

Conditional on the Placing becoming unconditional, the Directors have been granted a general unconditional mandate to exercise all the powers of the Company to repurchase Shares with a total nominal value of not more than 10 per cent. of the total nominal amount of the Shares in issue immediately following completion of the Placing and if applicable, which may be issued pursuant to the exercise of the Over-allotment Option).

This mandate only relates to repurchases made on GEM, or on any other stock exchange on which the Shares are listed (and which is recognised by the Securities and Futures Commission of Hong Kong and the Stock Exchange for this purpose), and which are in accordance with the GEM Listing Rules. A summary of the relevant GEM Listing Rules is set out in the section headed “Repurchase by the Company of its own securities” in Appendix IV to this prospectus.

This mandate will expire:

- at the end of the Company’s next annual general meeting; or
- at the end of the period within which the Company is required by any applicable laws or the Articles to hold its next annual general meeting; or
- when varied, revoked or renewed by an ordinary resolution of the shareholders of the Company in general meeting;

whichever occurs first.

For further details of the general mandate, see the paragraph headed “Written resolutions of the sole shareholder of the Company passed on 12th July, 2002 and 20th September, 2002” under the section headed “Further information about the Company” in Appendix IV to this prospectus.

# FINANCIAL INFORMATION

## INDEBTEDNESS

### Borrowings

As at the close of business on 31st July, 2002, being the latest practicable date for the purpose of ascertaining information contained in this indebtedness statement prior to the printing of this prospectus, the Group had outstanding secured bank borrowings of approximately RMB4.8 million, of which RMB0.7 million is payable within the forthcoming one year and the balance of approximately RMB4.1 million is due after one year.

### Securities

As at 31st July, 2002, the Group's borrowings were secured by fixed charge on a leasehold land and building of the Group with a net book value of approximately RMB8.4 million.

### Commitments and contingent liabilities

As at 31st July, 2002, the Group had operating lease commitments of approximately RMB3.2 million and commitments of approximately RMB5.6 million. Other than the above, the Group had no material commitments as at 31st July, 2002.

As at the same date, the Group had no material contingent liabilities.

### Foreign currency exposure

The Group's entire present operation is carried out in the PRC. All its receipts and payments in relation to the operation are denominated in RMB. In this respect, the Directors consider there is no currency mismatch in its operational cashflows and the Group is not exposed to any foreign currency exchange risk in its operation.

### Disclaimer

Save as referred to above or as otherwise disclosed herein and apart from intra-Group liabilities, the Group did not have, as at the close of business on 31st July, 2002, any mortgages, charges, debentures or other loan capital or bank overdrafts, loans or other similar indebtedness or hire purchase commitments or any guarantees or other material contingent liabilities.

The Directors have confirmed that there have been no material change in the indebtedness and contingent liabilities of the Group since 31st July, 2002.

### Rules 17.15 to 17.21 of the GEM Listing Rules

The Directors have confirmed that as at the Latest Practicable Date, the Group was not aware of any circumstances which would give rise to a disclosure requirement under Rules 17.15 to 17.21 of the GEM Listing Rules.

# FINANCIAL INFORMATION

## CAPITAL STRUCTURE, FINANCIAL RESOURCES AND LIQUIDITY

### Capital structure

As at 31st July, 2002, the Group had net assets of approximately RMB167.0 million, comprising non-current assets of approximately RMB46.4 million, net current assets of approximately RMB124.9 million, secured non-current portion mortgage loan of approximately RMB4.1 million and minority interests of approximately RMB0.2 million. As at 31st July, 2002, the Group's total current assets were approximately RMB140.8 million, comprising inventories of approximately RMB4.2 million, retention receivable of approximately RMB2.2 million, amount due from contract customers of approximately RMB3.8 million, trade receivables of approximately RMB36.9 million (As at 31st August, 2002, the outstanding trade receivables of the Group for the seven months ended 31st July, 2002 reduced to approximately RMB18.8 million mainly owing to the payments of installation projects' amounts and Products Sales amounts). Prepayments and other receivables of approximately RMB10.2 million and bank and cash balances of approximately RMB83.5 million. As at 31st July, 2002 the Group's total current liabilities were approximately RMB15.9 million, comprising trade and other payables of approximately RMB9.5 million, amount due to contract customers of approximately RMB0.3 million, tax liabilities of approximately RMB5.4 million and mortgage loan current portion of approximately RMB0.7 million.

### Borrowings and banking facilities

The Group generally finances its operations with internally generated resources and banking facilities provided by its bankers in the PRC.

As at 31st July, 2002, the Group had a mortgage loan of approximately RMB4.8 million which were secured by fixed charge on a leasehold land and building of the Group with a net book value of approximately RMB8.4 million.

### Directors' opinion on working capital position

The Group services its debts primarily through cash generated from its operations. The Directors are of the opinion that, taking into account its internally generated funds, its currently available borrowing facilities and the estimated net proceeds of the Placing, the Group has sufficient working capital to satisfy its present requirements.

## PROPERTY

### Properties owned in the PRC

The Group owns a property in Fuzhou which is used as the PRC head office of the Group. The property comprises two office floors on the 8th and 9th floors and three private car parking spaces on the basement of a commercial building named Gao Jing Trade Centre. It is located at No.158 Wu Yi Bei Road, Fuzhou City, Fujian Province, the PRC. The total gross floor area of office floors is approximately 1,722 sq. m. and the total gross floor area of private parking spaces on the basement is approximately 116 sq. m..

The Group also owns another property located at Unit B, 17th Floor, Jin Shan Building, No. 862 Xia He Road, Xiamen City, Fujian Province, the PRC. The property is the branch office premise of the Group in Xiamen and has a total gross floor area of 253 sq. m..

### Properties rented in the PRC

The Group leases a number of properties located in various cities in the PRC which are used as branch offices. The production plant and research and development department of the Group are currently located at No.83 Zhan Jin Xiang, Xian Feng Village, Cang Shan Town, Cang Shan District, Fuzhou City, Fujian Province of the PRC.

# FINANCIAL INFORMATION

## Property rented in Hong Kong

In Hong Kong, the Group leases an office unit at Units 6-7, Office B, 5th Floor, K. Wah Centre, No. 191 Java Road, North Point, Hong Kong as its representative office in Hong Kong.

## Property valuation

Greater China Appraisal Limited, an independent property valuer, valued the properties of the Group as at 31st July, 2002. The text of the letter, summary of valuations and the valuation certificate are set out in Appendix II to this prospectus.

## TRADING RECORD

The table below sets out a summary of the combined audited results of the Group for each of the two years ended 31st December, 2001 and the seven months ended 31st July, 2002.

		Year ended		Seven months
		31st December,		ended
		2000	2001	2002
	<i>Note</i>	<i>RMB'000</i>	<i>RMB'000</i>	<i>RMB'000</i>
Turnover	<i>1</i>	84,007	193,988	147,553
Cost of sales	<i>1</i>	<u>(32,979)</u>	<u>(76,716)</u>	<u>(54,465)</u>
Gross Profit	<i>1</i>	51,028	117,272	93,088
Other revenue		64	31	526
Distribution costs		(240)	(162)	(917)
Administrative expenses		<u>(6,002)</u>	<u>(10,386)</u>	<u>(8,936)</u>
Profit from operations		44,850	106,755	83,761
Finance costs		<u>(207)</u>	<u>(243)</u>	<u>(241)</u>
Profit before taxation		44,643	106,512	83,520
Taxation		<u>(184)</u>	<u>(7,728)</u>	<u>(8,833)</u>
Profit before minority interests		44,459	98,784	74,687
Minority interests		<u>(3,000)</u>	<u>(4,941)</u>	<u>(179)</u>
Net profit for the year/period		<u><u>41,459</u></u>	<u><u>93,843</u></u>	<u><u>74,508</u></u>
Dividends	<i>2</i>	<u><u>(21,745)</u></u>	<u><u>(88,216)</u></u>	<u><u>–</u></u>
Earnings per share, basic ( <i>cents</i> )	<i>3</i>	<u><u>3.00</u></u>	<u><u>6.79</u></u>	<u><u>4.83</u></u>

# FINANCIAL INFORMATION

Notes:

1. Turnover represents Product Sales, Installation Services and Maintenance Services of the Group. The details of such turnovers and the gross profits are as follows:

	Year ended 31st December,		Seven months
	2000	2001	ended 31st July, 2002
	RMB'000	RMB'000	RMB'000
Turnover			
Product Sales	70,875	143,092	89,518
Cost of Good sold	(26,461)	(50,154)	32,224
<b>Gross Profit</b>	<b>44,414</b>	<b>92,938</b>	<b>57,294</b>
Installation Services	13,132	48,400	50,970
Cost of Installation Services	(6,518)	(26,209)	(21,134)
<b>Gross Profit</b>	<b>6,614</b>	<b>22,191</b>	<b>29,836</b>
Maintenance Services	–	2,496	7,065
Cost of Maintenance Services	–	(353)	(1,107)
<b>Gross profit</b>	<b>–</b>	<b>2,143</b>	<b>5,958</b>
<b>Total turnover</b>	<b>84,007</b>	<b>193,988</b>	<b>147,553</b>
Cost of sales	(32,979)	(76,716)	(54,465)
<b>Total Gross Profit</b>	<b>51,028</b>	<b>117,272</b>	<b>93,088</b>

2. For the two years ended 31st December, 2001 and the seven months ended 31st July, 2002, the Group paid dividends of approximately RMB21.7 million, RMB55.2 million and nil, respectively to its then equity holders. In addition, a dividend of RMB33.0 million was declared in November 2001 and subsequently assigned by Mr. Jiang Xiong, the then equity holder of Wang Sing pursuant to the Reorganisation.
3. The calculation of the basic earnings per Share for each of the two years ended 31st December, 2001 are based on the combined profits for each of the respective years and on the 1,381,600,000 Shares attributable to Mr. Jiang Xiong as if those Shares had been in issue throughout the two years ended 31st December, 2001. The calculation of the basic earnings per Share for the seven months ended 31st July, 2002 is based on the combined profits for the seven months ended 31st July, 2002 and on the weighted average number of 1,541,279,245 Shares attributable to Mr. Jiang Xiong, Cantus, YMW and Morita as if those Shares had been in issue throughout the seven months ended 31st July, 2002.

There were no potential dilutive ordinary shares in issue during the two years ended 31st December, 2001 and the seven months ended 31st July, 2002.

## MANAGEMENT DISCUSSION AND ANALYSIS

### Overview

### Turnover

The Company's turnover is derived primarily from Product Sales, Installation Services and Maintenance Services in the order of importance.

# FINANCIAL INFORMATION

## Cost of sales

The Group's cost of product sales primarily consists of cost of raw materials such as electronic parts, plastic intrusion case, metal cases and other manufacturing cost such as labour costs and production overheads including depreciation. Cost of sales of Installation Services include cost of the purchase of parts and equipment of the various fire prevention and fighting systems.

## Gross profit

The Directors believe that the gross profit margin of approximately 60%, 60% and 63% maintained by the Group in the two years ended 31st December, 2001 and in the seven months ended 31st July, 2002 was principally attributed to the following reasons:

- (i) the appropriate pricing strategy of the Group;
- (ii) the healthy competition environment within the industry;
- (iii) the steady supply and cost of the raw materials;
- (iv) good control of overheads and other direct cost.

The Directors believe that in a foreseeable future such operating environment shall be able to be maintained.

## Operating expenses

The Company's operating expenses comprise distribution and selling expenses, and general and administrative expenses. Distribution and selling expenses mainly include business promotion and advertising expenses. General and administration expenses mainly include staff and directors' remuneration, rental of the production facilities and the premises of the branch offices, traveling and accommodation expenses.

## Financing expenses

Financing expenses refer to the mortgage charged to the office premises of the Group in Fuzhou.

## Taxation

The Company is not subject to Hong Kong profit tax as the Company did not generate any assessable profit in Hong Kong for the two years ended 31st December, 2001 and the seven months ended 31st July, 2002.

For each of the two years ended 31st December, 2001, Fujian Wanyou, being the Group's Product Sales arm, is entitled to a tax holiday from January 2000 to December 2001 as a privileged treatment to High New Technology Enterprise in Fujian Province. According to an approval of the Tax Bureau of Fujian Province dated 10th April, 2002, Fujian Wanyou, being the Group's Product Sales arm, is entitled to two year's exemption from income tax followed by three years of 50% tax reduction commencing from the first-profit-making year as a privileged treatment to a wholly foreign owned enterprise in the PRC. Wanyou Engineering, being the Group's Installation Services vehicle, is subject to an enterprise income tax of the PRC at a rate of 33% on its assessable profit.

## FINANCIAL INFORMATION

Apart from PRC Enterprise Income Tax, Fujian Wanyou is subject to value-added tax (“VAT”) which is the principal indirect tax on the sales of tangible goods (“output VAT”). Output VAT is calculated at 17% of the invoiced value of sales and is payable by the customer in addition to the invoiced value of sales. Fujian Wanyou pays VAT on its purchases (“input VAT”) which is deducted against output VAT in arriving at the net VAT amount payable. All VAT paid and collected is recorded through the VAT payable account, included in taxes payable on the balance sheet. On 31st January, 2002, Fujian Wanyou received a VAT clearance letter from the Fujian Tax Bureau regarding the payment of VAT. Pursuant to the letter, an amount of approximately RMB9,836,000 representing the additional non-deductible VAT payable for the period from 31st January, 1999 to 31st December, 2001 was charged and was subsequently paid by the Group in February 2002. The additional VAT represented the amount paid by Fujian Wanyou to the Fujian Tax Bureau after lengthy negotiation on the deductibility of input VAT payments on the purchases to set off the output VAT receipts on sales of Fujian Wanyou. Since the additional VAT has been finalised and accrued properly in the respective years, the Fujian Tax Bureau has confirmed that there is no further VAT liabilities of the Group during the Track Record Period. The additional VAT payable did not include any identifiable penalty or surcharge and was agreed on the basis of estimation based on the review carried out by the Fujian Tax Bureau.

Wanyou Engineering was entitled to a tax privilege of paying income tax at the rate of 1.5% on its turnover as it was considered as a small enterprise by the PRC tax bureau since January 1999. During the year 2001, in light of its significant growth in turnover and profit, the tax bureau indicated to Wanyou Engineering that the tax privilege was no longer applicable to Wanyou Engineering. Accordingly, Wanyou Engineering provided its income tax at the standard income tax rate of 33% from 2001 onwards. The change of applicable tax rate to Wanyou Engineering has been confirmed by the PRC tax bureau.

### Minority Interests

Minority interests represent the share of profits after taxation by the minority shareholders in both Fujian Wanyou and Wanyou Engineering based on their equity interests in each of Fujian Wanyou and Wanyou Engineering during the Track Record Period.

### Dividend policy

For each of the two years ended 31st December, 2001 the Group declared dividends of total amounts of approximately RMB22 million and RMB88 million, respectively to its then equity holders of the various members of the Group. The dividend payments in respect of the two years ended 31st December, 2001 were financed by the internal resources of the Group. There is no assurance that dividends of similar amount or at similar rate will be made in the future and the past dividend payments referred to above should not be used as a reference for the Company’s dividend policy nor a basis to forecast the amount of dividend payable in the future.

The declaration of, payment and amount of dividends will be subject to the discretion of the Directors and will be dependent upon the Group’s earnings, financial condition, cash requirements and availability, and other relevant factors. It is the Company’s current intention to recommend annually the distribution to shareholders of about 30% of the Company’s distributable annual earnings as cash dividends commencing from the first year after the Shares have been listed for a complete financial year. For the avoidance of doubt, if the Shares have not been listed for a complete financial year, dividend payment will be determined on a pro rata basis by making reference to an annual payout of 30% of the Company’s distributable annual earnings. Such dividend policy may be amended where: (i) the cash available to the Company is in an amount lower than the above mentioned amount; and (ii) there is a negative impact on the cash flow of the Group due to the investments made by the Company as approved by the Directors which are not fully covered by appropriate financing. The amounts of dividends actually distributed to holders of the Shares will depend upon the Company’s earnings and financial condition, operating requirements and capital requirements.

## FINANCIAL INFORMATION

The Directors expect that in future, interim and final dividends will be paid in or about October and June of each year respectively and that the interim dividend will normally represent approximately one-third of the expected total dividends for the full year.

### *Seven months ended 31st July, 2002*

#### *Turnover*

For the seven months ended 31st July, 2002, the net turnover of the Group was approximately RMB147.5 million which comprised approximately RMB89.5 million from Product Sales, approximately RMB50.9 million from Installation Services and approximately RMB7.1 million from Maintenance Services.

The percentage of Product Sales in Fuzhou to total Product Sales decreased from approximately 45.7% for the year ended 31st December, 2001 to approximately 29.5% for the seven months ended 31st July, 2002. On the other hand, the percentage of Product Sales in other districts to total Product Sales increased significantly from approximately 54.3% for the year ended 31st December, 2001 to approximately 70.5% for the seven months ended 31st July, 2002 as shown in the table below:

District	Turnover of Product Sales for the seven months ended 31st July, 2002 RMB'000	Percentage of Product Sales in various districts to total Product Sales		
		Year 2000	Year 2001	Seven months ended 31st July, 2002
Shanghai 上海	12,177	15.0%	13.8%	13.6%
Beijing 北京	13,183	3.3%	12.9%	14.7%
Jingxi 江西	10,618	3.1%	1.5%	11.9%
Xiamen 廈門	5,316	17.1%	12.1%	5.9%
Shandong 山東	4,127	3.4%	3.6%	4.6%
Jiangsu 江蘇	643	6.9%	1.5%	0.7%
Fuzhou 福州	26,420	33.0%	45.7%	29.5%
Fujian (excluding Fuzhou and Xiamen) 福建	8,605	17.2%	7.8%	9.6%
Others 其他	8,523	1.0%	1.1%	9.5%
Total	89,612	100%	100%	100%
Less: Sales tax	(94)			
	<u>89,518</u>			

The Directors believe that the variance in the percentage of Product Sales in different districts over the years was mainly owing to the following reasons:

- (i) the Group's reputation and network in the regions where its branch offices and distributors are located continue to consolidate and sales of products continue to increase accordingly; and



## FINANCIAL INFORMATION

- (ii) it is the Group's strategy to deliberately unload its reliance on Fuzhou market, therefore such marketing efforts were placed outside Fuzhou in 2001 and the seven months ended 31st July, 2002.

Product Sales accounted for approximately 60.7% of the turnover of the Group for the seven months ended 31st July, 2002 whereas that for the year ended 31st December, 2001 was about 73.8%. The reasons for the relative decrease are:

1. the increase in percentage of Installation Services from approximately 24.9% for the year ended 31st December, 2001 to approximately 34.5% for the seven months ended 31st July, 2002:

The increase in percentage of Installation Services for the seven months ended 31st July, 2002 was mainly attributable to the increase in the number of installation contracts that the Group received and performed. During the year ended 31st December, 2001, the Group had completed 19 projects in the Fujian Province. However, for the seven months ended 31st July, 2002, the Group had completed 12 projects and had 14 projects in progress in the Fujian Province. The Directors believe that the significant increase in the number of projects was mainly due to the success of business development given its competitive service quality and pricing strategy of the Group's Installation Services in the market. The turnover attributable to the seven months ended 31st July, 2002 amounted to about RMB51 million which was higher than that for the year ended 31st December, 2001, being approximately RMB48 million.

2. the increase in percentage of Maintenance Services from approximately 1.3% for the year ended 31st December, 2001 to approximately 4.8% for the seven months ended 31st July, 2002:

The increase in percentage of Maintenance Services for the seven months ended 31st July, 2002 was mainly attributable to the tightening of reinforcement of fire safety regulations especially after the announcement of Regulation of Fire Safety Administration for Governmental Offices, Organisations, Corporations and Business Units (機關、團體、企業、事業單位消防安全管理規定) (the "Regulations") in October 2001. The Regulations were in force commencing from May 2002. According to the Regulations, all types of organizations, corporations and business units are required to have the fire prevention and fighting systems and equipment inspected once for every quarter of a year by an authorized services provider. Accordingly, the demand from Maintenance Services increased substantially since the Group is one of the few authorized maintenance providers in the Fujian Province. The turnover attributable to Maintenance Services for the seven months ended 31st July, 2002 amounted to about RMB7.1 million which is about 280% of that for the year ended 31st December, 2001, being approximately RMB2.5 million.

### *Gross Profit*

For the seven months ended 31st July, 2002, the gross profit of Product Sales was approximately RMB57.3 million. The gross profit margin was approximately 64% which decreased slightly from approximately 64.9% for the year ended 31st December, 2001. The gross profit of Installation Services for the seven months ended 31st July, 2002 was approximately RMB29.8 million. The gross profit margin of Installation Services increased from approximately 45.8% for the year ended 31st December, 2001 to approximately 58.5% for the seven months ended 31st

## FINANCIAL INFORMATION

July, 2002 mainly due to the increased proportion of the revenue generated from Installation Services for governmental projects which usually have higher gross profit margin as compared to other types of buildings. The gross profit of Maintenance Services for the seven months 31st July, 2002 was approximately RMB5.9 million. The gross profit margin of Maintenance Services remains fairly stable at approximately 84.3% for the seven months ended 31st July, 2002, as compared to approximately 85.9% for the year ended 31st December, 2001.

Consumption of raw materials accounted for approximately 72% of the cost of Product Sales and approximately 84% of the Installation Services for the seven months ended 31st July, 2002.

### *Distribution costs and administrative expenses*

For the seven months ended 31st July, 2002, the distribution costs of the Group amounted to approximately RMB0.9 million, representing approximately 5.6 times of the distribution costs of the Group for the year ended 31st December, 2001. The significant increase in distribution costs were mainly due to the magazine advertisement costs and advertisement production charges of approximately RMB0.34 million and RMB0.12 million respectively incurred during the seven months ended 31st July, 2002. In order to promote the corporate image and the related products and services of the Group, there were several advertisements published in the journals and magazines on fire prevention and fighting products. Accordingly, the advertisement charges and production costs increased significantly.

For the seven months ended 31st July, 2002, the administrative expenses of the Group were approximately RMB8.9 million, representing approximately 86% of the total administrative expenses for the year ended 31st December, 2001. The significant increase in administrative expenses for the seven months ended 31st July, 2002 were mainly due to the significant increase in travelling expenses from approximately RMB0.6 million for the year ended 31st December, 2001 to approximately RMB1.1 million for the seven months ended 31st July, 2002. The Directors consider that more travelling expenses were incurred as the Group was implementing its strategy to increase Product Sales in regions other than Fuzhou. In addition, the Group established an office in Hong Kong in March 2002 and this incurred approximately RMB0.6 million comprising staff costs of approximately RMB0.3 million, rental of approximately RMB0.1 million and office expenses of approximately RMB0.2 million.

### *Year ended 31st December, 2001 compared to year ended 31st December, 2000*

#### *Turnover*

The Company's net turnover increased by RMB110 million or 130.9% owing to an increase in both the Product Sales and the Installation Services. For the year ended 31st December, 2001, Product Sales of the Group amounted to approximately RMB143.1 million, an increase of approximately 101.8% from Product Sales of approximately RMB70.9 million for the year ended 31st December, 2000. On the other hand, revenue generated from Installation Services increased by approximately 269.5% from approximately RMB13.1 million for the year ended 31st December, 2000 to approximately RMB48.4 million for the year ended 31st December, 2001. In view of the increasing demand for the Group's products and the limitation of capacity in the Group's then production facilities, the Group moved to the existing production facilities in July 2001. In addition to the increase in the Product Sales and Installation Services, the Group has commenced to generate revenue of approximately RMB2.5 million from Maintenance Services for the year ended 31st December, 2001.

## FINANCIAL INFORMATION

The increase in Product Sales of the Group for the year ended 31st December, 2001 was mainly due to the increase in sales of products in different cities in the PRC:

District		2000 <i>RMB'000</i>	2001 <i>RMB'000</i>
Shanghai	上海	10,859	20,118
Beijing	北京	2,403	18,837
Jiangxi	江西	2,236	2,167
Xiamen	廈門	12,362	17,626
Shandong	山東	2,486	5,268
Jiangsu	江蘇	5,021	2,106
Fuzhou	福州	23,909	66,599
Fujian (excluding Fuzhou and Xiamen)	福建	12,481	11,292
Others	其他	718	1,574
		<hr/>	<hr/>
Total		72,475	145,587
Less: Sales tax		(1,600)	(2,495)
		<hr/>	<hr/>
Net Sales		<u>70,875</u>	<u>143,092</u>

The significant increase in sales of approximately RMB73.1 million was mainly attributable to the expansion of sales in various cities in the PRC, which mainly include, Shanghai, Beijing and Fuzhou. Most of the branch offices of the Group were established in 1999 or 2000. After one to two years' operation, the Group had established reputation and network in the regions where the Group's branch offices are located. Accordingly, sales of products increase significantly in 2001. The sales in Shanghai increased by approximately RMB9.3 million, accounted for approximately 12.7% of the total increase in turnover. The sales in Beijing increased from approximately RMB2.4 million for the year ended 31st December, 2000 to approximately RMB18.8 million, an increase of RMB16.4 million representing approximately 22.4% of the total increase in turnover. The sales in Fuzhou increased significantly by approximately RMB42.7 million, representing approximately 58.4% of the total increase in turnover. In addition, the significant increase in sales was also due to the marketing and promoting efforts of the Group's sales personnels by participating in various conferences and exhibitions in various cities in the PRC, such as Ninxia, Changsha, Zengzhou and Chongqing in 2001.

The revenue generated from Installation Services increased from approximately RMB13 million for the year ended 31st December, 2000 to approximately RMB48 million for the year ended 31st December, 2001. The increase in turnover were mainly due to the completion of 19 projects in Fujian Province during the year 2001. Please refer to Page 2 of this prospectus in respect of the nature of such projects.

### *Gross Profit*

For the year ended 31st December, 2001, the gross profit of Product Sales was approximately RMB92.9 million while that of the year ended 31st December, 2000 was approximately RMB44.4 million. The gross profit margin recorded a slight increase from approximately 62.7% for the year ended 31st December, 2000 to approximately 64.9% for the year ended 31st December, 2001. In respect of the Installation Services, the gross profit increased from approximately RMB6.6 million for the year ended 31st December, 2000 to approximately RMB22.2 million for the year ended

## FINANCIAL INFORMATION

31st December, 2001. The gross profit margin of Installation Services decreased slightly from approximately 50.4% for the year ended 31st December, 2000 to approximately 45.8% for the year ended 31st December, 2001. The Directors believe that the substantial growth in gross profit of Product Sales and Installation Services were mainly attributable to the success of the Group's sales and marketing effort as well as its strict control in costs and quality in such activities. The Group commenced to provide Maintenance Services in the second half of 2001, which brought a remarkable gross profit of approximately RMB2.1 million to the Group representing a gross profit margin of approximately 85.9%. The Directors believe the high gross profit margin of Maintenance Services was mainly due to the tightening of fire prevention and fighting laws and regulations of fire services departments of different cities in Fujian and the lack of competition in Fujian.

Consumption of raw materials accounted for approximately 69% and 68% of the cost of Product Sales and 86% and 87% of the Installation Services for 2000 and 2001 respectively. In order to keep the labour costs at a lower level, the Group continued the policy of employing temporary workers for Installation Service projects.

As a result of the above, the Group's gross profit increased by 66.2 million or 129.8% in 2001.

### *Administrative expenses*

For the year ended 31st December, 2001, the administrative expenses of the Group amounted to approximately RMB10.4 million, an increase of approximately RMB4.4 million or approximately 73.3% as compared to that of approximately RMB6.0 million for the year ended 31st December, 2000. The increase in administrative expenses was mainly attributable to the (i) amortisation of goodwill from the acquisition of 21.36% equity interests in Wanyou Engineering in the hands of Mr. Jiang Qing of approximately RMB1.9 million and (ii) the increase in retirement benefit scheme for staff in the PRC of approximately RMB2.4 million commencing from January 2001. The goodwill arising from the acquisition of the 3% equity interests in Fujian Wanyou from Mr. Jiang Qing on 30th November, 2001 was approximately RMB440,000 and was not amortised in respect of the month ended 31st December, 2001 since the monthly amortisation was immaterial, which was approximately RMB7,333. In addition, according to 《社會保險費徵繳暫行條例》, provision of pension insurance became a mandatory obligation under the relevant regulations promulgated by the Fujian provincial government with effect from 1st January, 2001 onwards. Therefore, the social insurance of the Group increased significantly during the year 2001.

As a result of the above changes, the profit attributable to shareholders increased by RMB52.3 million or 126.0% from RMB41.5 million in 2000 to RMB93.8 million in 2001.

### **DISTRIBUTABLE RESERVES**

As at 31st July, 2002, the Company had not commenced its business and investments activities and hence there were no reserves available for distribution to the shareholders of the Company at that date.

### **WORKING CAPITAL**

The Directors are of opinion that, taking into account the internally generated resources of the Group and the estimated net proceeds from the issue of the New Shares (excluding the Over-allotment Shares) under the Placing, the Group has sufficient working capital for its present requirements.

# FINANCIAL INFORMATION

## ADJUSTED NET TANGIBLE ASSETS

The following pro forma statement of adjusted net tangible assets of the Group is based on the audited combined net tangible assets of the Group as at 31st July, 2002 as shown in the accountants' report set out in Appendix I to this prospectus, adjusted as described below:

	<i>RMB'000</i>
Audited combined net assets of the Group as at 31st July, 2002	167,049
<i>Less:</i> Intangible assets as at 31st July, 2002	(11,204)
Estimated net proceeds of the New Shares (assuming the Over-allotment Option not being exercised)	<u>145,856</u>
Adjusted net tangible assets of the Group	<u><u>301,701</u></u>
Adjusted net tangible asset value per Share ( <i>Note 2</i> )	<u><u>15.09 cents</u></u>

### *Notes:*

1. According to the valuation of the property interests of the Group as of 31st July, 2002 prepared by the Company's property valuer – Greater China Appraisal Limited, the aggregated valuation of the property interests of the Group was stated at HK\$11,300,000 (equivalent to approximately RMB11,978,000). On the basis of the net book value of those property interests at RMB9,978,000 as stated in the audited combined balance sheet of the Group as at 31st July, 2002, there is a revaluation surplus of approximately RMB2,000,000 arising from a revaluation of such properties. As disclosed in the "Risk Factors" section of this prospectus, the Group does not hold the land use right certificates of the property interests and the revaluation surplus of such properties are not incorporated in the accounts of the Group in order to comply with Rule 18.46 of the GEM Listing Rules. Should the revaluation surplus be incorporated in future accounts, the annual depreciation of the Group would increase by approximately RMB40,000. Property valuation surplus will not be incorporated in the Group's financial statements after the listing of the Shares on the Stock Exchange.
2. The adjusted net tangible asset value per Share is arrived at after the adjustments referred to in this section and on the basis of a total of 2,000,000,000 Shares expected to be in issue immediately following the completion of the Placing, but takes no account of any Shares which may fall to be issued pursuant to the exercise of the Over-allotment Option and options granted under the Share Option Scheme or which may be allotted and issued or repurchased by the Company pursuant to the general mandates for the allotment and issue or repurchase of Shares granted to the Directors as referred to in the paragraph headed "Written Resolutions of the sole shareholder of the Company passed on 12th July 2002 and 20th September, 2002" under the section headed "Further information about the Company" in Appendix IV to this prospectus.

## NO MATERIAL ADVERSE CHANGE

The Directors have confirmed that since 31st July, 2002 (being the date to which the latest audited combined financial statements of the Group were made up) there has been no material adverse change in the financial or trading position or prospects of the Group.

# UNDERWRITING

## UNDERWRITERS

Core Pacific – Yamaichi International (H.K.) Limited  
ICEA Capital Limited  
CLSA Limited  
Karl-Thomson Securities Company Limited  
Nomura International (Hong Kong) Limited  
Phoenix Capital Securities Limited  
Sun Hung Kai International Limited  
The Bank of East Asia, Limited

## UNDERWRITING ARRANGEMENTS AND EXPENSES

### Underwriting Agreement

Pursuant to the Underwriting Agreement, the Company is offering at the Issue Price 400,000,000 New Shares and the Vendor is offering at the Issue Price 100,000,000 Sale Shares for sale in Hong Kong on and subject to the terms and conditions therein.

Subject to the GEM Listing Committee granting listing of and permission to deal in the Shares in issue and the Shares to be issued as mentioned herein and to certain other conditions set out in the Underwriting Agreement, the Underwriters have severally agreed to subscribe for or purchase or procure places to subscribe for or purchase the Placing Shares in accordance with the terms and conditions in the Underwriting Agreement.

### Grounds for termination

The obligations of the Underwriters to subscribe for or purchase or procure subscribers or purchasers for the Placing Shares are subject to termination if certain events, including force majeure, occur at any time prior to 4:00 p.m. (Hong Kong time) on 27th September, 2002. CPY International and ICEA jointly but not severally (for themselves and on behalf of the Underwriters) have absolute right to terminate the obligations of the Underwriters under the Underwriting Agreement, as CPY International and ICEA in their sole and reasonable opinion see fit, at any time prior to the aforesaid time upon the occurrence of, but not limited to, any of the following events:

1. If there develops, occurs or comes into force:
  - (A) any event, or series of events, beyond the control of the Underwriters (including, without limitation, acts of government, strikes, lock-out, fire, explosion, flooding, civil commotion, war, riots, public disorder, epidemic, terrorism or acts of God or accident), which in the reasonable opinion of CPY International and ICEA (for themselves and on behalf of the Underwriters) have or is likely to have the effect of making any material part of the Underwriting Agreement incapable of performance in accordance with its terms or which prevents the processing of applications and/or payments pursuant to the Placing or pursuant to the underwriting or which might be expected to result in a material adverse change in political, economic or stock market conditions; or

## UNDERWRITING

- (B) any change (whether permanent or not) in local, national, international, financial, military, industrial, economic, fiscal, regulatory, political or stock market conditions and matters (including any moratorium, suspension or material restriction on trading in securities generally on the Stock Exchange) and/or the occurrence of any disasters, which in the reasonable opinion of CPY International and ICEA (for themselves and on behalf of the Underwriters) would materially prejudice the success of the Placing; or
  - (C) any new law or regulation or any change in existing laws or regulations or any change in the interpretation or application thereof by any court or other competent authority or any other similar event in the PRC, Hong Kong, the Cayman Islands, the BVI, the USA or any other jurisdictions relevant to the Group or other occurrence of any nature whatsoever which is in the reasonable opinion of CPY International and ICEA (for themselves and on behalf of the Underwriters) has or is likely to have a material adverse effect on the business or financial condition or prospects of any member of the Group; or
  - (D) the imposition of economic sanctions, in whatever form, directly or indirectly, by or for the USA or by the European Union (or any member thereof) or any jurisdictions relevant to the Group, which is in the reasonable opinion of CPY International and ICEA (for themselves and on behalf of the Underwriters) has or is likely to have a material adverse effect on the business or financial condition or prospects of any member of the Group; or
  - (E) any change or development occurs involving a prospective change in taxation or exchange control (or the implementation of any exchange control) in the PRC, Hong Kong, the Cayman Islands, the BVI or any other jurisdictions relevant to the Group affecting an investment in the Shares or the transfer or dividend payment in respect thereof or the implementation of exchange controls which will or may materially and adversely affect any member of the Group, which is in the reasonable opinion of CPY International and ICEA (for themselves and on behalf of the Underwriters) has or is likely to have a material adverse effect on the business or financial condition or prospects of any member of the Group; or
  - (F) any litigation or claim of material importance by any third party being threatened or instigated against any member of the Group, which is in the reasonable opinion of CPY International and ICEA (for themselves and on behalf of the Underwriters) has or is likely to have a material adverse effect on the business or financial condition or prospects of any member of the Group.
2. There comes to the notice of any of the Underwriters any breach by any of the Company and the executive Directors of any of the representations, warranties and undertaking given which would, in the reasonable opinion of CPY International and ICEA (for themselves and on behalf of the Underwriters), have a material adverse impact on the financial position or business or prospect of the Group taken as a whole or the success of the Placing.

# UNDERWRITING

3. There is any material adverse change in the business or in the financial or trading position or prospects of any member of the Group which is in the reasonable opinion of CPY International and ICEA (for themselves and on behalf of the Underwriters) material in the context of the Placing.
4. (A) There comes to the notice of CPY International and ICEA that any matter or event showing any of the warranties given under the Underwriting Agreement to be untrue, incorrect in any respect considered by CPY International and ICEA (for themselves and on behalf of the Underwriters) in their reasonable opinion to be material in the context of the Placing; or  
  
(B) any matter has arisen or has been discovered which would, had it arisen or been discovered immediately before the Latest Practicable Date, constitute an omission to disclose, considered by CPY International and ICEA (for themselves and on behalf of the Underwriters) in their reasonable opinion to be material; or  
  
(C) any of the Company, the executive Directors, the Initial Management Shareholder, the Substantial Shareholder or the Vendor who are parties to the Underwriting Agreement commits any material breach of, or omits to observe in any material respect, any of the obligations or undertakings expressed to be assumed by any of them under the Underwriting Agreement; or  
  
(D) there comes to the notice of CPY International and ICEA (for themselves and on behalf of the Underwriters) any information, matter or event which, in the reasonable opinion of CPY International and ICEA (for themselves and on behalf of the Underwriters): (i) is materially inconsistent with any information contained in any Form 6A given by any executive Director; or (ii) would cast any doubt on the integrity or reputation of any executive Director of any member of the Group; or (iii) would lead to a material and adverse change in the business or in the financial or trading position of the Group taken as a whole; or  
  
(E) there comes to the notice of CPY International and ICEA (for themselves and on behalf of the Underwriters) any event, act or omission which gives or is likely to give rise to any material liability of the Company, the executive Directors, the Initial Management Shareholder and the Substantial Shareholder pursuant to the indemnities referred to in the Underwriting Agreement.

## Undertakings

The Initial Management Shareholder and the Significant Shareholder have given non-disposal undertakings to the Company, CPY, the Underwriters and the Stock Exchange, details of which are described in the section headed “Substantial shareholder, initial management shareholder, significant shareholder and other shareholders” of this prospectus.

Pursuant to the Underwriting Agreement, each of the Company, the executive Directors, the Initial Management Shareholder and the Substantial Shareholder who are parties to the Underwriting Agreement has undertaken with CPY and the Underwriters to procure that, save as pursuant to and in compliance with the GEM Listing Rules, the Placing or pursuant to the exercise of the Over-allotment Option or pursuant to the exercise of any options which may be granted under the Share



# UNDERWRITING

Option Scheme or otherwise approved by the Stock Exchange, the Company will not, within the period of six months from the Listing Date, allot or issue or agree to allot or issue any securities in the Company (including warrants or other convertible securities and whether or not of a class already listed) or offer, sell grant or agree to sell or grant any options or other rights carrying rights to subscribe for or otherwise acquire any securities of the Company or placing to or agree to do any of the foregoing or announce any intention to do so.

## **Commission and expenses**

The Underwriters will receive an underwriting and placing commission of 3.5 per cent. of the aggregate Issue Price of all the Placing Shares (excluding Over-allotment Shares not having been placed). CPY will receive a documentation and financial advisory fee relating to the Placing. The underwriting and placing commission, documentation and financial advisory fee, the Stock Exchange listing fees, the Securities and Futures Commission transaction levy, the Stock Exchange trading fee, legal and other professional fees, printing and other expenses relating to the Placing which are currently estimated to be approximately HK\$28 million, which are payable by the Company as to 80% and Mr. Jiang Xiong as to 20% on a pro-rata basis. If the Over-allotment Option is exercised in full, the Group will bear 82.61% while Mr. Jiang Xiong will bear 17.39% of such commission, fees and expenses, respectively.

## **Sponsor's interests in the Company**

A sponsor's agreement dated 20th September, 2002 was entered into between CPY and the Company whereby the Company has appointed CPY to act as its sponsor for the purposes of the GEM Listing Rules for the remainder of the current financial year and the two further financial years ending 31st December, 2004 pursuant to which CPY will receive a fee.

Save as provided for under the Underwriting Agreement, neither CPY nor any of its associates has or may, as a result of the Placing, have any interest in any class of securities of the Company or any other companies in the Group (including options or rights to subscribe for such securities).

No director or employee of CPY who is involved in providing advice to the Company has or may, as a result of the Placing, have any interest in any class of securities of the Company or any other company in the Group (including options or rights to subscribe for such securities).

Neither CPY nor any of its associates has accrued any material benefit as a result of the successful outcome of the Placing, including by way of example, the repayment of material outstanding indebtedness or success fees save and except for the receipt of underwriting and placing commission by CPY International being one of the joint lead managers to the Placing and the documentation and financial advisory fee to be received by CPY pursuant to the Underwriting Agreement.

No director or employee of CPY nor any of its associates has a directorship in the Company or any other company in the Group.

Save as provided for under the Underwriting Agreement and disclosed otherwise in this prospectus, none of the Underwriters has any shareholding interests in any member of the Group nor has any right or option (whether legally enforceable or not) to subscribe for or nominate persons to subscribe for any shares in any member of the Group.

# UNDERWRITING

## **Underwriters' Interests in the Company**

Save as provided for under the Underwriting Agreement and otherwise disclosed in this prospectus, none of the Underwriters has any shareholding interests in any member of the Group nor has any right or option (whether legally enforceable or not) to subscribe for or nominate persons to subscribe for any shares in any member of the Group except that CLSA Limited, being one of the Underwriters, and Cantus are fellow members of CLSA Emerging Market Group.

## **Over-allotment Option**

The Company has granted to the Underwriters the Over-allotment Option, exercisable by ICEA, on behalf of the Underwriters, within 30 days after the date of this prospectus, to require the Company to allot and issue up to an aggregate of 75,000,000 Shares, which is equivalent to 15 per cent. of the Placing Shares, to such person or persons as ICEA shall direct at the Issue Price solely to cover any over-allocations under the Placing.

# STRUCTURE AND CONDITIONS OF THE PLACING

## PRICE PAYABLE ON SUBSCRIPTION

Investors have to pay the Issue Price of HK\$0.40 plus 1 per cent. brokerage, a 0.005 per cent. trading fee payable to the Stock Exchange, and a 0.007 per cent. transaction levy payable to the Securities and Futures Commission, constituting a total of HK\$2,020.24 per board lot of 5,000 Shares. All stamp duty payable on the Sale Shares shall be borne by Mr. Jiang Xiong solely.

## PLACING

The Company and the Vendor are collectively initially offering 500,000,000 Placing Shares, representing approximately 25 per cent. of the issued share capital of the Company immediately after completion of the Placing, assuming the Over-allotment Option is not exercised, pursuant to the Placing. Assuming the Over-allotment Option is not exercised, the Placing Shares comprise 400,000,000 New Shares, representing approximately 80 per cent. of the Placing Shares and approximately 20 per cent. of the issued share capital of the Company immediately after completion of the Placing, and 100,000,000 Sale Shares, representing approximately 20 per cent. of the Placing Shares and approximately 5 per cent. of the issued share capital of the Company immediately after completion of the Placing, to be sold by Mr. Jiang Xiong. The Placing is fully underwritten by the Underwriters, subject to the terms and conditions of the Underwriting Agreement.

Pursuant to the Placing, the Underwriters or selling agents nominated by the Underwriters on behalf of the Company shall place the Placing Shares (comprising 400,000,000 New Shares and 100,000,000 Sale Shares) at the Issue Price payable by the subscribers and/or purchasers of the Placing Shares. The Placing Shares will be placed with professional and institutional investors and other investors anticipated to have a sizable demand for the Placing Shares in Hong Kong. Professional investors generally include brokers, dealers and companies (including fund managers) whose ordinary business involves dealing in securities and entities which regularly invest in securities.

The total number of Placing Shares to be placed pursuant to the Placing may change as a result of any exercise of the Over-allotment Option.

## CONDITIONS OF THE PLACING

Acceptance of applications for the Placing Shares in the Placing is conditional upon inter alia:

1. the GEM Listing Committee granting listing of, and permission to deal in, the Shares in issue and the Shares to be issued pursuant to the Placing (including any shares to be issued pursuant to the exercise of the Over-allotment Option or any options which may be granted under the Share Option Scheme); and
2. the obligations of the Underwriters under the Underwriting Agreement becoming unconditional (including, if relevant, as a result of the waiver of any condition(s) by CPY International and ICEA (on behalf of the Underwriters)) and not being terminated in accordance with the terms of the Underwriting Agreement or otherwise,

in each case, on or before the dates and times specified in the Underwriting Agreement (unless and to the extent such conditions are validly waived on or before such dates and times) and in any event not later than 22nd October, 2002, being the date which is 30 days after the date of this prospectus.

# STRUCTURE AND CONDITIONS OF THE PLACING

## OVER-ALLOTMENT OPTION

Pursuant to the Underwriting Agreement, the Company has granted to the Underwriters an Over-allotment Option which is exercisable by ICEA, on behalf of the Underwriters, to require the Company to allot and issue up to an aggregate of 75,000,000 new Shares (subject to adjustment) at any time and from time to time within 30 days from the date of this prospectus. These Over-allotment Shares shall represent approximately 15 per cent. of the number of Placing Shares initially offered under the Placing, at the Issue Price solely to cover over-allocations in the Placing, if any. In order to facilitate the settlement of over-allocations in connection with the Placing in an efficient manner, ICEA may choose to borrow Shares from Mr. Jiang Xiong, under the stock borrowing agreement prior to any exercise of the Over-allotment Option, or the acquisition of a sufficient number of Shares from other sources. Mr. Jiang Xiong will not receive any payment or benefit in respect of such stock borrowing arrangement. Pursuant to such stock borrowing arrangement, any Shares borrowed but not sold pursuant to the Over-allotment Option must be returned to Mr. Jiang Xiong and deposited with the escrow agent no later than three business days following the last date for exercising the Over-allotment Option, if, and only if the Over-allotment Option is not exercised in full. Any stock borrowing arrangement to be entered into will be conducted in accordance with all applicable laws and regulatory requirements. In the event that the Over-allotment Option is exercised, an announcement will be made by the Company setting out the relevant details.

## STABILISATION

In connection with the Placing, ICEA (on behalf of the Underwriters) may over-allocate up to an aggregate of 75,000,000 Shares, representing approximately 15 per cent. of the Placing Shares (such over-allocations may be covered by exercising the Over-allotment Option in full or in part, at any time up to 30 days from the date of this prospectus, by stock borrowing or by purchasing Shares in the secondary market) and/or effect transactions which stabilise or maintain the market price of the Shares at levels other than those which might otherwise prevail but which are not higher than the Issue Price. Any such over-allocation purchase and/or transactions will be made in compliance with all applicable laws and regulatory requirements.

Mr. Jiang Xiong has agreed with ICEA that he will make available to ICEA on a temporary basis by way of stock borrowing arrangements, up to a total of 75,000,000 Shares, to facilitate the settlement of over-allocations in connection with the Placing before the exercise of the Over-allotment Option.

ICEA may also on behalf of the Underwriters effect transactions which stabilise or maintain the market price of the Shares. Such transactions may be effected in all jurisdictions where it is permissible to do so, in each case, in compliance with all applicable laws and regulatory requirements. Such transactions, if commenced, may be discontinued at any time. Should stabilising transactions be effected in connection with the distribution of Shares, they will be done at the absolute discretion of ICEA.

Stabilisation is a practice used by underwriters in some markets to facilitate the distribution of securities. To stabilise, the underwriters may bid for or purchase, the newly issued securities in the secondary market, during a specified period of time, to retard and, if possible, prevent a decline in the initial issue price of the securities. The stabilisation price to cover over-allocations will not exceed the initial issue price.

## **STRUCTURE AND CONDITIONS OF THE PLACING**

In Hong Kong, such stabilisation activities on the Stock Exchange are restricted to cases where the underwriters purchase shares in the secondary market genuinely and solely for the purpose of covering over-allocations in the relevant offer. Such transactions, if commenced, may be discontinued at any time. The relevant provisions of the Securities Ordinance prohibit market manipulation in the form of pegging or stabilising the price of securities in certain circumstances.

## 德勤·關黃陳方會計師行

Certified Public Accountants  
26/F, Wing On Centre  
111 Connaught Road Central  
Hong Kong

香港中環干諾道中111號  
永安中心26樓

**Deloitte  
Touche  
Tohmatsu**

23rd September, 2002

The Directors

Wanyou Fire Safety Technology Holdings Limited  
Core Pacific-Yamaichi Capital Limited

Dear Sirs,

We set out below our report on the financial information (“Financial Information”) relating to Wanyou Fire Safety Technology Holdings Limited (the “Company”) and its subsidiaries (hereinafter collectively referred to as the “Group”) for each of the two years ended 31st December, 2001 and the seven months ended 31st July, 2002 (the “Relevant Period”) for inclusion in the prospectus of the Company dated 23rd September, 2002 (the “Prospectus”).

The Company was incorporated in the Cayman Islands as an exempted company with limited liability under the Companies Law (2001 Second Revision) Chapter 22 of the Cayman Islands on 3rd January, 2002.

Through a group reorganisation as more fully explained in paragraph headed “Corporate Reorganisation” in Appendix IV to the Prospectus (the “Corporate Reorganisation”), the Company became the holding company of the following subsidiaries.

As at the date of this report, the Company has the following subsidiaries:

Name	Place and date of incorporation/ registration	Issued and fully paid share capital/ registered capital	Attributable equity interest held by		Principal activities
			the Company	the Group	
Wang Sing Technology Limited	British Virgin Islands 12th October, 2000	US\$4,984,359	100%	–	Investment holding
Fujian Wanyou Fire Fighting Science and Technology Co., Ltd. (“Fujian Wanyou”)	People’s Republic of China (“PRC”) <i>Note (1)</i> 20th December, 1993	HK\$10,500,000	–	100% <i>(Note 2)</i>	Production and sales of fire prevention and fighting products

Name	Place and date of incorporation/ registration	Issued and fully paid share capital/ registered capital	Attributable equity interest held by the Company	the Group	Principal activities
福建省萬友消防工程 有限公司 Fujian Wanyou Fire Engineering Company Limited ("Wanyou Engineering")	PRC 23rd December, 1996	RMB7,063,600	-	99% (Note 3)	Provision of fire prevention and fighting systems installation services and maintenance services
Wang You Fire Technology Limited ("US Wanyou")	State of Delaware, United States of America 5th March, 2002	US\$1	-	100%	Dormant

## Notes:

- (1) Fujian Wanyou was an enterprise established on 20th December, 1993 in the PRC with limited liability and was formerly known as "Fujian Wanyou Enterprises Group Ltd." It changed its legal status to a wholly foreign-owned enterprise ("WFOE") on 17th December, 2001 with its name changed to Fujian Wanyou.
- (2) Wang Sing Technology Limited acquired from the directors of the Company Mr. Jiang Xiong and Mr. Jiang Qing their equity interests in Fujian Wanyou of 97% and 3% respectively on 18th November, 2001, for a total consideration of HK\$40,000,000. Pursuant to the Corporate Reorganisation as detailed in appendix IV of the Prospectus, Wang Sing Technology Limited holds 100% interest in Fujian Wanyou with the 3% interest in Fujian Wanyou acquired from Mr. Jiang Qing accounted for on the basis of acquisition accounting from the date of acquisition of 18th November, 2001.
- (3) Wanyou Engineering was originally 68.81% held by Fujian Wanyou on 1st January, 2000. On 12th March, 2001, Fujian Wanyou increased its holding in Wanyou Engineering to 77.64% by the injection of RMB2,000,000 capital to Wanyou Engineering and Fujian Wanyou further acquired 21.36% interest from the director of the Company, Mr. Jiang Qing at a consideration of RMB18,000,000 on 28th March, 2001. The increase in interests in Wanyou Engineering in 2001 was accounted for on the basis of acquisition accounting from their respective dates of acquisition.

No audited financial statements have been prepared for the Company and US Wanyou since their respective dates of incorporation as they have not carried on any business, other than the acquisition of subsidiaries by the Company. We have, however, reviewed all relevant transactions of the Company and US Wanyou since their respective dates of incorporation and carried out such procedures as we considered necessary for inclusion of the financial information relating to these companies.

We have acted as the auditors of Wang Sing Technology Limited from its date of incorporation.

The statutory financial statements of Fujian Wanyou and Wanyou Engineering prepared in accordance with the relevant accounting rules and financial regulations in the PRC for the Relevant Period or such shorter period, where appropriate, except for the statutory financial statements of Fujian Wanyou for the period from 1st December, 2001 to 31st December, 2001 and from 1st January, 2002 to 31st July, 2002, which were audited by Fujian Nanqiang Certified Public Accountants Ltd., registered in the PRC, have not been audited. For the purpose of this report, we

have undertaken our own independent audits of the financial statements, prepared in accordance with accounting principles generally accepted in Hong Kong, of Fujian Wanyou and Wanyou Engineering for the Relevant Period in accordance with Statements of Auditing Standards issued by the Hong Kong Society of Accountants.

We have examined the audited financial statements or, where appropriate, management accounts of the companies now comprising the Group for the Relevant Period, or since the respective dates of incorporation to 31st July, 2002, where this is a shorter period. Our examination was made in accordance with the Auditing Guideline "Prospectuses and the Reporting Accountant" as recommended by the Hong Kong Society of Accountants.

The Financial Information for the Relevant Period set out in this report have been prepared from the audited financial statements or management accounts (the "Underlying Financial Statements") of the companies comprising the Group, on the basis set out in note 1 to the Financial Information, after making such adjustments as we consider appropriate for the purpose of preparing our report for inclusion in the Prospectus.

The Underlying Financial Statements are the responsibility of the directors of those companies who approve their issue. The directors of the Company are responsible for the contents of the Prospectus in which this report is included. It is our responsibility to compile the Financial Information set out in this report from the Underlying Financial Statements, to form an opinion on the Financial Information and to report our opinion to you.

In our opinion, on the basis of presentation set out in note 1 below, the Financial Information gives, for the purpose of this report, a true and fair view of the state of affairs of the Group as at 31st December, 2000 and 2001 and as at 31st July, 2002 and of the combined results and cash flows of the Group for each of the two years ended 31st December, 2001 and the seven months ended 31st July 2002.



## (A) FINANCIAL INFORMATION

## COMBINED INCOME STATEMENTS

		Year ended 31st December,		Seven months ended 31st July,
		2000	2001	2002
	NOTES	RMB'000	RMB'000	RMB'000
Turnover	3	84,007	193,988	147,553
Cost of sales		<u>(32,979)</u>	<u>(76,716)</u>	<u>(54,465)</u>
Gross profit		51,028	117,272	93,088
Other revenue	4	64	31	526
Distribution costs		(240)	(162)	(917)
Administrative expenses		<u>(6,002)</u>	<u>(10,386)</u>	<u>(8,936)</u>
Profit from operations		44,850	106,755	83,761
Finance costs	5	<u>(207)</u>	<u>(243)</u>	<u>(241)</u>
Profit before taxation	6	44,643	106,512	83,520
Taxation	8	<u>(184)</u>	<u>(7,728)</u>	<u>(8,833)</u>
Profit before minority interests		44,459	98,784	74,687
Minority interests		<u>(3,000)</u>	<u>(4,941)</u>	<u>(179)</u>
Net profit for the year/period		<u><u>41,459</u></u>	<u><u>93,843</u></u>	<u><u>74,508</u></u>
Dividends	9	<u><u>(21,745)</u></u>	<u><u>(88,216)</u></u>	<u><u>–</u></u>

There were no recognised gains or losses other than net profit for the Relevant Period.

## COMBINED BALANCE SHEETS

		At 31st December,		At
	NOTES	2000	2001	31st July,
		RMB'000	RMB'000	2002
				RMB'000
<b>Non-current assets</b>				
Property, plant and equipment	11	3,896	36,841	35,213
Retention receivables	12	182	50	32
Goodwill	13	–	12,927	11,204
		<u>4,078</u>	<u>49,818</u>	<u>46,449</u>
<b>Current assets</b>				
Other investments	14	920	920	–
Inventories	16	4,839	2,950	4,153
Retention receivables	12	542	2,597	2,227
Amounts due from contract customers	17	4,433	3,111	3,808
Trade debtors	18	1,336	3,616	36,841
Prepayments and other receivables	19	1,828	2,269	10,228
Amounts due from related parties	15	–	502	–
Bank balances and cash		35,470	57,836	83,502
		<u>49,368</u>	<u>73,801</u>	<u>140,759</u>
<b>Current liabilities</b>				
Trade and other payables	20	2,768	12,910	9,504
Amounts due to contract customers	17	–	3,194	327
Amounts due to related parties	21	10,455	51,474	–
Tax liabilities	22	5,076	17,302	5,358
Bank borrowings – due within one year	23	2,000	4,000	731
		<u>20,299</u>	<u>88,880</u>	<u>15,920</u>
<b>Net current assets (liabilities)</b>		29,069	(15,079)	124,839
<b>Non-current liabilities</b>				
Bank borrowings – due after one year	23	–	–	4,023
<b>Minority interests</b>		<u>4,156</u>	<u>121</u>	<u>216</u>
		<u>28,991</u>	<u>34,618</u>	<u>167,049</u>
<b>Capital and reserves</b>				
Paid-in capital	24	10,185	10,185	10,268
Other reserves	25	7,767	16,461	74,301
Retained profits	26	11,039	7,972	82,480
		<u>28,991</u>	<u>34,618</u>	<u>167,049</u>

## COMBINED CASH FLOW STATEMENTS

	Year ended		Seven months
	31st December, 2000	2001	ended 31st July, 2002
	RMB'000	RMB'000	RMB'000
Cash flows from operating activities			
Profit before taxation	44,643	106,512	83,520
Adjustments for:			
Depreciation	336	744	1,831
Amortisation of goodwill	–	1,896	1,723
Interest income	(18)	(20)	(273)
Interest expenses	207	243	241
	<u>          </u>	<u>          </u>	<u>          </u>
Operating profits before working capital changes	45,168	109,375	87,042
Decrease (increase) in inventories	1,340	1,889	(1,203)
(Increase) decrease in amounts due from contract customers	(72)	1,322	(697)
(Increase) decrease in retention receivables	(724)	(1,923)	388
Decrease (increase) in amounts due from related parties	903	(502)	502
Increase in trade debtors	(383)	(2,280)	(33,225)
Decrease (increase) in prepayments and other receivables	1,326	(441)	(7,959)
(Decrease) increase in amounts due to contract customers	(1,350)	3,194	(2,867)
Increase (decrease) in trade and other payables	295	18,326	(14,396)
Increase (decrease) in amounts due to related parties	8,599	5,747	(50,202)
	<u>          </u>	<u>          </u>	<u>          </u>
Cash generated from (used in) operations	55,102	134,707	(22,617)
Interest paid	(207)	(243)	(241)
Income tax paid	(4,651)	(3,686)	(9,787)
	<u>          </u>	<u>          </u>	<u>          </u>
Net cash inflow (outflow) from operating activities	<u>50,244</u>	<u>130,778</u>	<u>(32,645)</u>
Investing activities			
Purchase of property, plant and equipment	(2,642)	(33,689)	(203)
Acquisition of additional interests in a subsidiary	–	(18,000)	(1,272)
Proceeds from disposal of other investments	–	–	920
Purchase of other investments	(920)	–	–
Interest received	18	20	273
	<u>          </u>	<u>          </u>	<u>          </u>

	Year ended 31st December,		Seven months ended 31st July,
	2000	2001	2002
	RMB'000	RMB'000	RMB'000
Net cash outflow from investing activities	<u>(3,544)</u>	<u>(51,669)</u>	<u>(282)</u>
Financing activities			
New bank loans raised	4,000	4,000	7,120
Repayment of bank loans	(4,000)	(2,000)	(6,366)
Dividend paid	(21,745)	(55,236)	–
Dividend paid to minority shareholders	(673)	(3,507)	(84)
Proceeds from issue of shares of a subsidiary	<u>–</u>	<u>–</u>	<u>57,923</u>
Cash (outflow) inflow from financing activities	<u>(22,418)</u>	<u>(56,743)</u>	<u>58,593</u>
Net increase in cash and cash equivalents	24,282	22,366	25,666
Cash and cash equivalents at the beginning of the year/period	<u>11,188</u>	<u>35,470</u>	<u>57,836</u>
Cash and cash equivalents at the end of the year/period ( <i>Note 28</i> )	<u><u>35,470</u></u>	<u><u>57,836</u></u>	<u><u>83,502</u></u>

## NOTES TO THE FINANCIAL INFORMATION

## 1. BASIS OF PRESENTATION OF FINANCIAL INFORMATION

The combined income statements and combined cash flow statements include the results and cash flows of the companies comprising the Group as if the current group structure had been in existence throughout the Relevant Period or since the respective dates of establishment of the individual group companies where there are shorter periods, except that the additional interests in subsidiaries which were acquired for cash consideration during the Relevant Period were accounted for on the basis of acquisition accounting from their respective dates of acquisition. The combined balance sheets of the Group as at 31st December, 2000 and 2001 and as at 31st July, 2002 have been prepared to present the assets and liabilities of the Group as if the current group structure had been in existence as at those dates except that the additional interests in subsidiaries, which were not previously held by Mr. Jiang Xiong and acquired by cash consideration during the Relevant Period, were recognised upon acquisition.

All significant intra-group transactions and balances have been eliminated on combination.

## 2. SIGNIFICANT ACCOUNTING POLICIES

The Financial Information set out in this report has been prepared under the historical cost convention.

The principal accounting policies which have been adopted in preparing the Financial Information set out in this report and which conform with accounting principles generally accepted in Hong Kong are as follows:

**Revenue recognition**

Revenue on installation contracts is recognised using the percentage of completion method by reference to the value of work carried out during the year/period.

Sales of goods are recognised when goods are delivered and title has been passed.

Service income is recognised when services are provided.

Interest income from bank deposits is accrued on a time basis by reference to the principal outstanding and at the interest rate applicable.

**Goodwill**

Goodwill arising on consolidation represents the excess of the cost of acquisition over the Group's interest in the fair value of the identifiable assets and liabilities of a subsidiary at the date of acquisition.

Goodwill is capitalised and amortised on a straight-line basis over its useful economic life. Goodwill arising on the acquisition of subsidiaries is presented separately in the balance sheet.

On disposal of a subsidiary, the attributable amount of unamortised goodwill is included in the determination of the profit or loss on disposal.

**Property, plant and equipment**

Property, plant and equipment are stated at cost less accumulated depreciation and impairment losses.

Depreciation is provided to write off the cost of items of property, plant and equipment, using the straight line method, over their estimated useful lives which are as follows:

Leasehold land	Over the unexpired term of the relevant lease
Leasehold buildings	20 years
Other assets	5 – 10 years

The gain or loss arising from disposal or retirement of an asset is determined as the difference between the sale proceeds and the carrying amount of the asset and is recognised in the income statement.

**Inventories**

Inventories are stated at the lower of cost and net realisable value. Cost is calculated using the weighted average method.

**Installation contracts**

When the outcome of an installation contract can be estimated reliably, revenue and costs are recognised in the income statement by reference to the stage of completion of the contract activity at the balance sheet date, as measured by the proportion that contract costs incurred for work performed to date bear to the estimated total contract costs.

Variations in contract works, claims and incentive payments are included to the extent that they have been agreed with the customers.

When the outcome of an installation contract cannot be estimated reliably, revenue is recognised only to the extent of contract costs incurred that is probable will be recoverable. Contract costs are recognised as an expense in the period in which they are incurred.

When it is probable that total contract costs will exceed total contract revenue, the expected loss is recognised as an expense immediately.

**Impairment of assets**

At each balance sheet date, the Group reviews the carrying amounts of its tangible and intangible assets to determine whether there is any indication that those assets have suffered an impairment loss. If the recoverable amount of an asset is estimated to be less than its carrying amount, the carrying amount of the asset is reduced to its recoverable amount. Impairment losses are recognised as an expense immediately.

Where an impairment loss subsequently reverses, the carrying amount of the asset is increased to the revised estimate of its recoverable amount, but so that the increased carrying amount does not exceed the carrying amount that would have been determined had no impairment loss been recognised for the asset in prior years. A reversal of an impairment loss is recognised as income immediately.

**Taxation**

The charge for taxation is based on the results for the year after adjusting for items which are non-assessable or disallowed. Certain items of income and expense are recognised for tax purposes in a different accounting period from that in which they are recognised in the financial statements. The tax effect of the resulting timing differences, computed under the liability method, is recognised as deferred taxation in the financial statements to the extent that it is probable that a liability or asset will crystallise in the foreseeable future.

**Operating leases**

Rentals under operating leases are charged to the income statement on a straight line basis over the term of the relevant lease.

**Retirement benefits schemes**

Contributions payable by the Group for retirement benefits schemes are charged as an expense in the income statement as they fall due.

**Foreign currencies**

Transactions in currencies other than Renminbi are initially recorded at the rates of exchange ruling on dates of the transactions. Monetary assets and liabilities denominated in such currencies are re-translated at the rates ruling on the balance sheet date. Gains and losses arising on exchange are dealt with in the income statement.

On consolidation, the financial statements of subsidiaries which are denominated in currencies other than Renminbi are translated at the rates ruling on the balance sheet date. All exchange differences arising on consolidation are dealt with in the reserves.

## 3. TURNOVER

Turnover represents the aggregate of the value of installation contract work carried out, the sales proceeds of goods sold and income from provision of maintenance services during the Relevant Period, and is analysed as follows:

	Year ended		Seven months
	31st December,		ended
	2000	2001	31st July,
	RMB'000	RMB'000	2002
			RMB'000
Revenue from installation contracts	13,572	50,075	52,632
Sales of goods	72,475	145,587	89,612
Provision of maintenance services	—	2,588	7,295
	<u>86,047</u>	<u>198,250</u>	<u>149,539</u>
Less: Sales tax	(2,040)	(4,262)	(1,986)
	<u>84,007</u>	<u>193,988</u>	<u>147,553</u>

Sales tax represents various local tax levied on the invoiced value of goods sold.

## 4. OTHER REVENUE

	Year ended		Seven months
	31st December,		ended
	2000	2001	31st July,
	RMB'000	RMB'000	2002
			RMB'000
Other revenue includes:			
Interest income	18	20	273
Others	46	11	253
	<u>64</u>	<u>31</u>	<u>526</u>

## 5. FINANCE COSTS

	Year ended		Seven months
	31st December,		ended
	2000	2001	31st July,
	RMB'000	RMB'000	2002
			RMB'000
Interest on:			
Bank borrowings wholly repayable within five years	207	243	127
Bank borrowings with instalments repayable after five years	—	—	114
	<u>207</u>	<u>243</u>	<u>241</u>

## 6. PROFIT BEFORE TAXATION

	Year ended		Seven months
	31st December,		ended
	2000	2001	31st July,
	RMB'000	RMB'000	2002
			RMB'000
Profit before taxation has been arrived at after charging:			
Depreciation:			
Property, plant and equipment	336	744	1,831
Auditors' remuneration	–	5	–
Amortisation of goodwill	–	1,896	1,723
Allowance for doubtful debts	675	185	168
Operating lease rentals in respect of rented premises	805	742	265
Staff costs, including directors' remuneration	6,850	14,162	11,649
Retirement benefits scheme contributions, including those included in directors' remuneration	–	2,391	978
	<u>6,850</u>	<u>16,553</u>	<u>12,627</u>
and after crediting:			
Reversal of bad debts written off	–	–	418
Interest income	18	20	273
	<u>18</u>	<u>20</u>	<u>273</u>

## 7. DIRECTORS' AND EMPLOYEES' EMOLUMENTS

## (i) Directors' emoluments

	Year ended		Seven months
	31st December,		ended
	2000	2001	31st July,
	RMB'000	RMB'000	2002
			RMB'000
Fees	–	–	–
Other emoluments:			
Salaries and other benefits	75	100	56
Performance related incentive payments	–	–	–
Retirement benefits scheme contributions	–	18	10
	<u>75</u>	<u>118</u>	<u>66</u>
	<u>75</u>	<u>118</u>	<u>66</u>

Emoluments of the directors were as follows:

Executive			
Director A	25	44	25
Director B	25	30	17
Director C	25	44	24
	<u>25</u>	<u>44</u>	<u>24</u>



## (ii) Employees' emoluments

During the Relevant Period, the five highest paid individuals included 3, 2 and 2 directors of the Company for the year ended 31st December, 2000, the year ended 31st December, 2001 and the seven months ended 31st July, 2002 respectively, details of whose emoluments are set out above. The emoluments of the remaining highest paid individuals were as follows:

	Year ended		Seven months
	31st December,		ended
	2000	2001	31st July,
	RMB'000	RMB'000	2002
			RMB'000
Salaries and other benefits	50	90	364
Performance related incentive payments	–	–	–
Retirement benefits scheme contributions	–	16	12
	<u>50</u>	<u>106</u>	<u>376</u>

During the Relevant Period, no emoluments were paid by the Group to the directors and highest paid employees as an inducement to join or upon joining the Group or as compensation for loss of office and no director waived any emoluments during the Relevant Period.

## 8. TAXATION

	Year ended		Seven months
	31st December,		ended
	2000	2001	31st July,
	RMB'000	RMB'000	2002
			RMB'000
The charge comprises:			
The PRC	<u>184</u>	<u>7,728</u>	<u>8,833</u>

No provision for Hong Kong Profits Tax has been made as the Group's income neither arises in, nor is derived from Hong Kong.

Income tax on profits arising from the PRC has been provided based on the prevailing tax rates applicable to the respective companies comprising the Group.

With effect from the year 2000, Fujian Wanyou is classified as a High New Technology Enterprise by the tax bureau of the PRC and is accordingly exempted from PRC income tax for two years ended 31st December, 2001. After the change of status to WFOE, Fujian Wanyou is entitled to the two years' exemption from income tax followed by three years of 50% tax reduction commencing from the first-profit-making year with effect from 2002. In addition, if the revenue generated from product sales of Fujian Wanyou during a year is less than 50% of its revenue earned for that year, no exemption or reduction of income tax will be allowed and full income tax has to be paid even though it falls within the exemption or reduction of tax preferential treatment.

Wanyou Engineering is subject to the income tax computed at the rate of 1.5% on invoiced amount for the year ended 31st December, 2000 and at the rate of 33% on its taxable profit thereafter.

There is no significant unprovided deferred taxation during the Relevant Period and as at the respective balance sheet dates.

## 9. DIVIDENDS

	Year ended 31st December,		Seven months ended 31st July,
	2000	2001	2002
	RMB'000	RMB'000	RMB'000
Interim dividends paid	21,745	55,236	–
Interim dividends declared	–	32,980	–
	<u>21,745</u>	<u>88,216</u>	<u>–</u>

No dividend has been paid or declared by the Company during the Relevant Period.

Dividends shown above represent dividends declared and/or paid by the subsidiaries to their then equity participants during the Relevant Period.

The rate of dividend and number of shares ranking for dividends are not presented as such information is not meaningful for the purpose of this report.

## 10. EARNINGS PER SHARE

No earnings per share figure is presented as its inclusion, for the purpose of this report, is not considered meaningful due to the preparation of the results for the Relevant Period on a combined basis, as disclosed in note 1 above.

## 11. PROPERTY, PLANT AND EQUIPMENT

	Land and buildings RMB'000	Plant and equipment RMB'000	Furniture and fixtures RMB'000	Computers RMB'000	Motor vehicles RMB'000	Total RMB'000
<b>COST</b>						
At 1st January, 2000	–	1,303	154	41	1,045	2,543
Additions	–	2,502	20	42	78	2,642
At 31st December, 2000	–	3,805	174	83	1,123	5,185
<b>DEPRECIATION</b>						
At 1st January, 2000	–	291	47	13	602	953
Provided for the year	–	176	28	10	122	336
At 31st December, 2000	–	467	75	23	724	1,289
<b>NET BOOK VALUE</b>						
At 31st December, 2000	–	3,338	99	60	399	3,896
<b>COST</b>						
At 1st January, 2001	–	3,805	174	83	1,123	5,185
Additions	10,142	14,707	7,847	598	395	33,689
At 31st December, 2001	10,142	18,512	8,021	681	1,518	38,874
<b>DEPRECIATION</b>						
At 1st January, 2001	–	467	75	23	724	1,289
Provided for the year	13	404	178	17	132	744
At 31st December, 2001	13	871	253	40	856	2,033
<b>NET BOOK VALUE</b>						
At 31st December, 2001	10,129	17,641	7,768	641	662	36,841
<b>COST</b>						
At 1st January, 2002	10,142	18,512	8,021	681	1,518	38,874
Additions	–	90	77	36	–	203
At 31st July, 2002	10,142	18,602	8,098	717	1,518	39,077
<b>DEPRECIATION</b>						
At 1st January, 2002	13	871	253	40	856	2,033
Provided for the period	151	1,355	222	42	61	1,831
At 31st July, 2002	164	2,226	475	82	917	3,864
<b>NET BOOK VALUE</b>						
At 31st July, 2002	9,978	16,376	7,623	635	601	35,213

The land and buildings are held in the PRC under medium term lease.

The net book value of land and buildings under mortgage amounted to approximately RMB8,435,000 as at 31st July, 2002 and there was no mortgage of the land and buildings as at 31st December, 2001.

## 12. RETENTION RECEIVABLES

The amounts represent retention money in respect of the progress payments receivable on the contract works and are normally receivable one year after completion of the relevant contracts.

## 13. GOODWILL

	<i>RMB'000</i>
AT COST	
At 1st January, 2000 and 2001	–
Arising on acquisition of additional interests in subsidiaries	14,823
	<u>14,823</u>
At 31st December, 2001 and at 31st July, 2002	14,823
AMORTISATION	
At 1st January, 2000 and 2001	–
Provided for the year	1,896
	<u>1,896</u>
At 31st December, 2001	1,896
Provided for the period	1,723
	<u>1,723</u>
At 31st July, 2002	3,619
	<u>3,619</u>
NET BOOK VALUES	
At 31st July, 2002	11,204
	<u><u>11,204</u></u>
At 31st December, 2001	12,927
	<u><u>12,927</u></u>
At 31st December, 2000	–
	<u><u>–</u></u>

The goodwill is amortised over 5 years.

## 14. OTHER INVESTMENTS

These investments were acquired in 2000 by the Group and determined to be sold in 2001. The transaction was completed in 2002 resulting no gain or loss on disposals. Accordingly, the investments were classified as current assets as at 31st December, 2000 and 2001.

## 15. AMOUNTS DUE FROM RELATED PARTIES

The amounts comprising current accounts with a director of the Company and a company controlled by the close family members of a director of the Company were unsecured, interest free and had no fixed repayment terms.

## 16. INVENTORIES

Inventories represent fire prevention and fighting equipment and are stated at cost at the balance sheet dates.

	At 31st December, 2000	At 31st December, 2001	At 31st July, 2002
	<i>RMB'000</i>	<i>RMB'000</i>	<i>RMB'000</i>
Raw materials	3,722	1,028	1,134
Work-in-progress	740	351	331
Finished goods	377	1,571	2,688
	<u>4,839</u>	<u>2,950</u>	<u>4,153</u>
	<u><u>4,839</u></u>	<u><u>2,950</u></u>	<u><u>4,153</u></u>

## 17. AMOUNTS DUE FROM (TO) CONTRACT CUSTOMERS

	At 31st December, 2000	At 31st December, 2001	At 31st July, 2002
	<i>RMB'000</i>	<i>RMB'000</i>	<i>RMB'000</i>
Contract costs incurred plus net profits recognised	21,928	54,316	88,138
<i>Less: Progress billings</i>	<u>(17,495)</u>	<u>(54,399)</u>	<u>(84,657)</u>
	<u>4,433</u>	<u>(83)</u>	<u>3,481</u>
Comprising:			
Amounts due from contract customers	4,433	3,111	3,808
Amounts due to contract customers	<u>–</u>	<u>(3,194)</u>	<u>(327)</u>
	<u>4,433</u>	<u>(83)</u>	<u>3,481</u>

## 18. TRADE DEBTORS

The credit period allowed by the Group to its customers is normally 30-90 days.

The aged analysis of trade debtors is as follows:

	At 31st December, 2000	At 31st December, 2001	At 31st July, 2002
	<i>RMB'000</i>	<i>RMB'000</i>	<i>RMB'000</i>
Within 30 days	853	3,223	29,210
31 – 60 days	–	–	7,613
61 – 90 days	–	–	–
Over 90 days	<u>483</u>	<u>393</u>	<u>18</u>
	<u>1,336</u>	<u>3,616</u>	<u>36,841</u>

## 19. PREPAYMENTS AND OTHER RECEIVABLES

	At 31st December, 2000	At 31st December, 2001	At 31st July, 2002
	<i>RMB'000</i>	<i>RMB'000</i>	<i>RMB'000</i>
Prepayments and other receivables	3,780	4,406	12,533
<i>Less: Allowance for doubtful debts</i>	<u>(1,952)</u>	<u>(2,137)</u>	<u>(2,305)</u>
	<u>1,828</u>	<u>2,269</u>	<u>10,228</u>

## 20. TRADE AND OTHER PAYABLES

	At 31st December, 2000	At 31st December, 2001	At 31st July, 2002
	<i>RMB'000</i>	<i>RMB'000</i>	<i>RMB'000</i>
Trade creditors	2,129	4,044	243
Accrued costs and charges	499	3,746	4,452
Temporary receipts	140	–	4,809
Amount payable on acquisition of properties	<u>–</u>	<u>5,120</u>	<u>–</u>
	<u>2,768</u>	<u>12,910</u>	<u>9,504</u>

The aged analysis of trade creditors included in trade and other payables is as follows:

	At 31st December, 2000	2001	At 31st July, 2002
	<i>RMB'000</i>	<i>RMB'000</i>	<i>RMB'000</i>
Within 30 days	1,286	2,626	57
31 – 60 days	125	1,055	–
61 – 90 days	59	–	–
Over 90 days	659	363	186
	<u>2,129</u>	<u>4,044</u>	<u>243</u>

## 21. AMOUNTS DUE TO RELATED PARTIES

The amounts comprising current accounts with directors of the Company, close family members of the Company's directors and/or companies controlled by them were unsecured, interest free and had no fixed repayment terms.

Should interest be charged on the outstanding amounts due to related parties during the Relevant Period at the short-term bank borrowing rate prevailing in the PRC, the interest expenses during the Relevant Period would be as follows:

	Year ended 31st December, 2000	2001	Seven months ended 31st July, 2002
	<i>RMB'000</i>	<i>RMB'000</i>	<i>RMB'000</i>
Interest expenses	<u>576</u>	<u>1,257</u>	<u>1,092</u>

## 22. TAX LIABILITIES

	At 31st December, 2000	2001	At 31st July, 2002
	<i>RMB'000</i>	<i>RMB'000</i>	<i>RMB'000</i>
Value added tax	4,648	12,084	1,257
Sales tax and other levies	243	991	828
Income tax	185	4,227	3,273
	<u>5,076</u>	<u>17,302</u>	<u>5,358</u>

## 23. BANK BORROWINGS

	At 31st December, 2000	At 31st December, 2001	At 31st July, 2002
	<i>RMB'000</i>	<i>RMB'000</i>	<i>RMB'000</i>
Bank loans	2,000	4,000	–
Mortgage loan	–	–	4,754
	<u>2,000</u>	<u>4,000</u>	<u>4,754</u>
Secured	–	–	4,754
Unsecured	2,000	4,000	–
	<u>2,000</u>	<u>4,000</u>	<u>4,754</u>

The maturity of the above loans are as follows:

On demand or within one year	2,000	4,000	731
More than one year , but not exceeding two years	–	–	731
More than two years, but not exceeding five years	–	–	2,195
More than five years	–	–	1,097
	<u>2,000</u>	<u>4,000</u>	<u>4,754</u>
<i>Less:</i> Amounts due within one year shown under current liabilities	<u>(2,000)</u>	<u>(4,000)</u>	<u>(731)</u>
Amounts due after one year	<u>–</u>	<u>–</u>	<u>4,023</u>

## 24. PAID-IN CAPITAL

The combined paid-in capital of the Group represents the aggregate amount of the capital of the companies comprising the Group attributable to the Company as at the respective balance sheet dates.

## 25. OTHER RESERVES

	Statutory surplus reserve	Statutory public welfare fund	Statutory reserve fund	Capital reserve	Total
	<i>RMB'000</i>	<i>RMB'000</i>	<i>RMB'000</i>	<i>RMB'000</i>	<i>RMB'000</i>
At 1st January, 2000	730	365	–	–	1,095
Transfer from retained profits	<u>4,448</u>	<u>2,224</u>	<u>–</u>	<u>–</u>	<u>6,672</u>
At 31st December, 2000 and 1st January, 2001	5,178	2,589	–	–	7,767
Transfer from retained profits	<u>1,902</u>	<u>4,904</u>	<u>1,888</u>	<u>–</u>	<u>8,694</u>
At 31st December, 2001 and 1st January, 2002	7,080	7,493	1,888	–	16,461
Arising from issue of shares of a subsidiary	<u>–</u>	<u>–</u>	<u>–</u>	<u>57,840</u>	<u>57,840</u>
At 31st July, 2002	<u>7,080</u>	<u>7,493</u>	<u>1,888</u>	<u>57,840</u>	<u>74,301</u>

**(a) Statutory surplus reserve**

Pursuant to the articles of association of the group companies established in the PRC, the group companies are required to appropriate 10% of their respective profits after taxation determined in accordance with the relevant PRC accounting rules and financial regulations before appropriation of profits each year to the statutory surplus reserve until their balances reach 50% of their respective registered capital. In normal circumstances, the statutory surplus reserve shall only be used for making up losses, capitalisation into capital and expansion of their respective production and operation.

**(b) Statutory public welfare fund**

Pursuant to the articles of association of the group companies, the group companies established in the PRC are required to appropriate from their respective aforesaid profits after taxation at the rate of 5% to 10% to the statutory public welfare fund. The statutory public welfare fund can only be utilised on capital items for employees collective welfare. Individual employees only have the right to use these facilities, the titles to which will remain with the group companies. The statutory public welfare fund forms part of the equity and is non-distributable other than in liquidation.

**(c) Statutory reserve fund**

In accordance with the Law of the PRC on foreign enterprises, Fujian Wanyou is required to transfer an amount of not less than 10% of its profit after tax to the statutory reserve fund, which may be used for making up losses and capitalisation into capital.

**(d) Capital reserve**

The capital reserve represents the share premium arising from the issue of 1,365 shares of Wang Sing Technology Limited on 27th February 2002 for HK\$54,576,500.

**26. RETAINED PROFITS (LOSSES)**

	Year ended		Seven months
	31st December,		ended
	2000	2001	31st July,
	RMB'000	RMB'000	2002
			RMB'000
At beginning of the year/period	(2,003)	11,039	7,972
Net profit for the year/period	41,459	93,843	74,508
Dividends paid	(21,745)	(88,216)	–
Transfer to statutory surplus reserve	(4,448)	(1,902)	–
Transfer to statutory public welfare fund	(2,224)	(4,904)	–
Transfer to statutory reserve fund	–	(1,888)	–
	<u>          </u>	<u>          </u>	<u>          </u>
At end of the year/period	<u>11,039</u>	<u>7,972</u>	<u>82,480</u>



## 27. SEGMENT INFORMATION

## (a) Business segments

For the year ended 31st December, 2000

	Fire prevention and fighting systems installation RMB'000	Sale of fire prevention and fighting products RMB'000	Provision of maintenance services RMB'000	Eliminations RMB'000	Combined RMB'000
<b>REVENUE</b>					
External sales	13,132	70,875	–	–	84,007
Inter-segment sales	–	1,585	–	(1,585)	–
Total revenue	<u>13,132</u>	<u>72,460</u>	<u>–</u>	<u>(1,585)</u>	<u>84,007</u>
<b>RESULTS</b>					
Segment result	5,526	39,324	–	–	44,850
Finance costs					(207)
Profit before taxation					44,643
Taxation					(184)
Profit before minority interests					44,459
Minority interests					(3,000)
Net profit for the year					<u>41,459</u>
As at 31st December, 2000					
<b>ASSETS</b>					
Segment assets	<u>12,701</u>	<u>39,825</u>	<u>–</u>	<u>–</u>	52,526
Unallocated corporate assets					920
					<u>53,446</u>
<b>LIABILITIES</b>					
Segment liabilities	<u>1,302</u>	<u>6,357</u>	<u>–</u>	<u>–</u>	7,659
Unallocated corporate liabilities					12,640
					<u>20,299</u>
<b>OTHER INFORMATION</b>					
Additions of property, plant and equipment	92	2,550			
Depreciation	70	266			

For the year ended 31st December, 2001

	Fire prevention and fighting systems installation RMB'000	Sale of fire prevention and fighting products RMB'000	Provision of maintenance services RMB'000	Eliminations RMB'000	Combined RMB'000
<b>REVENUE</b>					
External sales	48,400	143,092	2,496	–	193,988
Inter-segment sales	–	9,967	–	(9,967)	–
Total revenue	<u>48,400</u>	<u>153,059</u>	<u>2,496</u>	<u>(9,967)</u>	<u>193,988</u>
<b>RESULTS</b>					
Segment result	19,141	85,471	2,143	–	106,755
Finance costs					(243)
Profit before taxation					106,512
Taxation					(7,728)
Profit before minority interests					98,784
Minority interests					(4,941)
Net profit for the year					<u>93,843</u>
As at 31st December, 2001					
<b>ASSETS</b>					
Segment assets	<u>39,331</u>	<u>82,866</u>	<u>–</u>	<u>–</u>	122,197
Unallocated corporate assets					1,422
					<u>123,619</u>
<b>LIABILITIES</b>					
Segment liabilities	<u>8,465</u>	<u>20,714</u>	<u>–</u>	<u>–</u>	29,179
Unallocated corporate liabilities					59,701
					<u>88,880</u>
<b>OTHER INFORMATION</b>					
Additions of property, plant and equipment and intangible assets	14,407	34,105			
Depreciation and amortisation	1,976	664			

For the seven months ended 31st July, 2002

	Fire prevention and fighting systems installation RMB'000	Sale of fire prevention and fighting products RMB'000	Provision of maintenance service RMB'000	Eliminations RMB'000	Combined RMB'000
<b>REVENUE</b>					
External sales	50,970	89,518	7,065	–	147,553
Inter-segment sales	–	12,688	–	(12,688)	–
Total revenue	<u>50,970</u>	<u>102,206</u>	<u>7,065</u>	<u>(12,688)</u>	<u>147,553</u>
<b>RESULTS</b>					
Segment result	19,138	59,336	5,958	–	84,432
Finance costs					(241)
Unallocated corporate expenses					<u>(671)</u>
Profit before taxation					83,520
Taxation					<u>(8,833)</u>
Profit before minority interests					74,687
Minority interests					<u>(179)</u>
Net profit for the period					<u>74,508</u>
As at 31st July, 2002					
<b>ASSETS</b>					
Segment assets	<u>56,172</u>	<u>126,611</u>	<u>2,121</u>	<u>–</u>	184,904
Unallocated corporate assets					<u>2,304</u>
					<u>187,208</u>
<b>LIABILITIES</b>					
Segment liabilities	<u>2,093</u>	<u>5,013</u>	<u>4,809</u>	<u>–</u>	11,915
Unallocated corporate liabilities					<u>8,028</u>
					<u>19,943</u>
<b>OTHER INFORMATION</b>					
Additions of property, plant and equipment	90	–			
Depreciation and amortisation	1,724	1,823			

## (b) Geographical segments

No geographical segment information in respect of the Group's operations has been presented as all the Group's operations was derived from the PRC.

The analysis of the carrying amount of segment assets and additions to property, plant and equipment and intangible assets analysed by the geographical areas in which the assets are located is as follows:

	Carry amount of segment assets			Additions to property, plant and equipment and intangible assets		
	At 31st December,		At 31st July,	Year ended		Seven months ended
	2000	2001	2002	31st December,	2001	31st July,
	RMB'000	RMB'000	RMB'000	2000	RMB'000	2002
				RMB'000	RMB'000	RMB'000
PRC	53,446	123,619	184,904	2,642	48,512	90
Hong Kong	-	-	2,304	-	-	113
	<u>53,446</u>	<u>123,619</u>	<u>187,208</u>	<u>2,642</u>	<u>48,512</u>	<u>203</u>

## 28. ANALYSIS OF THE BALANCES OF CASH AND CASH EQUIVALENTS

	At 31st December, 2000	At 31st December, 2001	At 31st July, 2002
	RMB'000	RMB'000	RMB'000
Bank balances and cash	<u>35,470</u>	<u>57,836</u>	<u>83,502</u>

## 29. MAJOR NON-CASH TRANSACTIONS

Pursuant to the Corporate Reorganisation, details of which are set out in Appendix IV of the Prospectus, Mr. Jiang Xiong assigned his entitlement of interests in the total amount of HK\$38.8 million due from Fujian Wanyou, being a dividend receivable of RMB32.98 million and a current account receivable of RMB8.14 million to Wang Sing Technology Limited at a nominal value in order to contribute the cost of investment in Wang Sing Technology Limited. In order to settle the amount due from Fujian Wanyou to Wang Sing Technology Limited resulting from the abovementioned assignment, Fujian Wanyou has applied to the State Administration of Foreign Exchange, Fujian Province Office on 1st July, 2002 for approval of the swapping of foreign exchange to settle in full the aforesaid amount due to Wang Sing Technology Limited. The application is still in progress as at the date of this report. Details of the application are set out in subparagraph (h) under paragraph headed "Corporate Reorganisation" in Appendix IV to the Prospectus. All the retained earnings of approximately of HK\$38.8 million in the books of Wang Sing Technology Limited arising from the assignment referred to the above were capitalized by Wang Sing Technology Limited on 20th September, 2002 by allotment and issue of shares to the Company.

Wang Sing Technology Limited, a wholly-owned subsidiary of the Company, entered into an agreement during the year ended 31st December, 2001 with Mr. Jiang Xiong and Mr. Jiang Qing to acquire 97% and 3% respectively held by them in Fujian Wanyou at a consideration of HK\$38.8 million and HK\$1.2 million respectively. The consideration payable was paid in March 2002.

## 30. COMMITMENTS

	At 31st December, 2000	At 31st December, 2001	At 31st July, 2002
	RMB'000	RMB'000	RMB'000
Contracted for but not provided in the financial statements in respect of:			
- acquisition of moulds	-	-	500
- acquisition of technical know-how	-	-	3,350
- research and development projects	-	-	1,700
	<u>-</u>	<u>-</u>	<u>5,550</u>

**31. OPERATING LEASE COMMITMENTS**

At the respective balance sheet dates, the outstanding commitments under non-cancellable operating leases in respect of premises were as follows:

	At 31st December, 2000	At 31st December, 2001	At 31st July, 2002
	<i>RMB'000</i>	<i>RMB'000</i>	<i>RMB'000</i>
Amounts payable:			
Within one year	510	263	495
In the second to fifth year inclusive	720	778	982
Over five years	–	1,805	1,694
	<u>1,230</u>	<u>2,846</u>	<u>3,171</u>

**32. NET LIABILITIES OF THE COMPANY**

The net liabilities of the Company as at 31st July, 2002 amounted to approximately RMB7,000.

**33. RELATED PARTY TRANSACTIONS**

During the Relevant Period, the following related party transactions took place:

1. The Group maintained interest free current accounts with directors of the Company, close family members of the Company's directors and/or companies controlled by them. Details of the balances due to and from the related parties are set out in Notes 21 and 15 respectively.
2. On 28th March, 2001, a director of the Company disposed of his holding of 21.36% interest in Wanyou Engineering to Fujian Wanyou at a consideration of RMB18,000,000 and on 18th November, 2001, disposed of his holding of 3% interest in Fujian Wanyou to the Group at a consideration of HK\$1,200,000 in accordance with the Corporate Reorganisation.
3. On 26th February, 2002, Wang Sing Technology Limited issued 8,634 shares to Mr. Jiang Xiong for cash at par.
4. During the Relevant Period, the bank facilities of the Group were secured on guarantees from a company controlled by the close family members of a director of the Company.

The directors of the Company have confirmed that these related party transactions will not continue after the Company's shares are listed on The Stock Exchange of Hong Kong Limited (the "Stock Exchange").

**34. RETIREMENT BENEFITS SCHEMES**

As stipulated by the rules and regulations in the PRC, the Group contributes to a state-sponsored retirement plan for its employees in the PRC. With effective from 1st January, 2001, the Group contributed at rates ranging from approximately 18% to 19% of the basic salaries of its eligible employees to the retirement plan and has no further obligation for the actual payment of the previous or post retirement benefits. The state-sponsored retirement plan is responsible for the entire present obligation to retired employees.

In accordance with the relevant mandatory provident fund laws and regulations of Hong Kong, the Group operates a Mandatory Provident Fund ("MPF") scheme ("MPF Scheme") for all qualifying Hong Kong employees. The assets of the scheme are held separately from those of the Group and under the control of an independent MPF service provider. Under the rules of the MPF Scheme, the employer and its employees are each required to make contributions to the scheme at rates specified in the rules. The only obligation of the Group with respect of the MPF Scheme is to make the required contributions under the scheme.

**35. SUBSEQUENT EVENTS**

Subsequent to 31st July, 2002, the following significant events took place:

- (1) The companies comprising the Group underwent a reorganisation in preparation for listing of shares of the Company on the Stock Exchange, details of which are set out in the section headed "Corporate Reorganisation" in Appendix IV to the Prospectus; and
- (2) On 20th September, 2002, the Company became the holding company of the Group.

Save as aforesaid, no other significant events took place subsequent to 31st July, 2002.

**(B) DIRECTORS' REMUNERATION**

Save as disclosed in this report, no remuneration has been paid or is payable in respect of the period covered by this report by the Company or any of its subsidiaries to the Company's directors.

Under the arrangement presently in force, the aggregate amount of the directors' fees and emoluments for the year ending 31st December, 2002 is estimated to be approximately HK\$700,000.

**(C) SUBSEQUENT FINANCIAL STATEMENTS**

No audited financial statements have been prepared by any companies in the Group in respect of any period subsequent to 31st July, 2002.

Yours faithfully,

**Deloitte Touche Tohmatsu**  
*Certified Public Accountants*

*The following is the text of the letter, summary of valuations and valuation certificate received from Greater China Appraisal Limited, prepared for the purpose of inclusion in this prospectus, in connection with its valuation as at 31st July, 2002 of the properties of the Group in Hong Kong and the PRC.*

**GREATER CHINA APPRAISAL LIMITED**

漢華評值有限公司

2407 Shui On Centre  
6-8 Harbour Road  
Wanchai  
Hong Kong

23rd September, 2002

The Directors  
Wanyou Fire Safety Technology Holdings Limited  
Units 506 and 507  
Office B  
5th Floor  
K. Wah Centre  
No. 191 Java Road  
North Point  
Hong Kong

Dear Sirs,

In accordance with your instructions to value the property interests of Wanyou Fire Safety Technology Holdings Limited (referred to as the “Company”) and its subsidiaries (together referred to as the “Group”) in the People’s Republic of China (referred to as the “PRC”) and Hong Kong, we confirm that we have carried out inspections, made relevant enquiries and obtained such further information as we consider necessary for the purpose of providing the capital values of such property interests as at 31st July, 2002 (referred to as the “date of valuation”).

This letter which forms parts of our valuation report explains the basis and methodology of valuation, and sets out our assumptions made, titleship of properties and the limiting conditions.

**BASIS OF VALUATION**

Our valuation is our opinion of the open market value which we would define as intended to mean “the best price at which the sale of an interest in property would have been completed unconditionally for cash consideration on the date of valuation assuming:

- (i) a willing seller;
- (ii) that, prior to the date of valuation, there had been a reasonable period (having regard to the nature of the property and the state of the market) for the proper marketing of the interest, for the agreement of price and terms and for the completion of the sale;
- (iii) that the state of the market, level of values and other circumstances were, on any earlier assumed date of exchange of contracts, the same as on the date of valuation;

- (iv) that no account is taken of any additional bid by a purchaser with a special interest; and
- (v) that both parties to the transaction had acted knowledgeably, prudently and without compulsion.”

### **VALUATION METHODOLOGY**

In valuing the property nos. 1 to 2 which are owned and occupied by the Group in the PRC, comparison approach is adopted where comparison based on recent prices realized on actual sales or market price information of comparable properties in the open market is made. Comparable properties of similar size, character and location are analyzed and carefully weighed against all the respective advantages and disadvantages of each property in order to arrive at a fair comparison of capital values.

Property nos. 3 to 16 which are rented and occupied by the Group in the PRC and Hong Kong has no commercial value due mainly to the prohibition against assignment or sub-letting or otherwise due to lack of substantial profit rents.

### **ASSUMPTIONS**

Our valuation has been made on the assumption that on the open market the Group sells the property interests in their continued uses and in their existing states without the benefit of any deferred terms, contracts, leaseback, joint ventures, management agreements or any similar arrangements which would serve to increase the value of the property interests.

For the property interests which are held by the Group with unexpired term, we have assumed that the owner of the property interests has free and uninterrupted rights to use the properties for the whole of the unexpired term of their respective land use rights term. Furthermore, we have valued the property interest on the assumption that it can be freely disposable and transferable to third parties in the open market without paying any premium to the PRC government. Unless otherwise stated, vacant possession is assumed for the property concern.

We have assumed that all consents, approvals and licenses from relevant government authorities for the buildings and structures erected thereon have been granted. Also, we have assumed that all buildings and structures falling within the site are held by the owner or permitted to be occupied by the owner.

We have assumed that all necessary mortgagees' consent to the creation of the tenancy over the properties have been obtained and are still subsisting.

### **TITLESHIP INVESTIGATION**

We have been provided with certain copies of the legal documents relating to title regarding the property interests under valuation for property nos. 1 to 2. We have been provided copy of the property collateral loan contract dated 21st January, 2002 for property no.1 that property no.1 is subject to a mortgage loan in favor of Agricultural Bank of China, Fuzhou City, Hudong Branch, for a loan of RMB5,120,000 for a term of 7 years. We have been given copies of the tenancy agreements for property nos. 3 to 16. We have caused searches to be made at the Land Registry in Hong Kong for property no. 16. However, due to the current registration system of the PRC, no investigations have been made for the legal title or any liabilities attached to the properties in the PRC.



In addition, we have been provided with the PRC legal opinion in relation to the Group's legal title to and the nature of the land interest in the properties concerned which we should have relied upon.

In the course of our valuation, we have assumed that the property interests are currently held by the Group which has the rights to occupy, use, sell, lease, charge, mortgage or otherwise dispose of the interests within their respective term of land use rights granted by the government without the need to seek further approval from and paying any addition premium to the government.

All legal documents disclosed in this report are for reference only and no responsibility is assumed for any legal matters concerning the legal title to the property interests set out in this report.

### **LIMITING CONDITIONS**

Since the properties situated in the PRC are located in a relatively under-developed market, the PRC, those assumptions are often based on imperfect market evidence. A range of values may be attributable to the property depending upon the assumptions made. While the valuer has exercised his professional judgement in arriving at the value, investors are urged to consider carefully the nature of such assumptions which are disclosed in the valuation report and should exercise caution in interpreting the valuation report.

We have not carried out detailed site measurements to verify the correctness of the land or building areas in respect of the relevant properties but have assumed that the areas shown on the legal documents provided to us are correct. Based on our experience of valuation of similar properties in Hong Kong and the PRC, we consider the assumptions so made to be reasonable. All documents and contracts have been used as reference only and all dimensions, measurements and areas are approximations.

We have inspected the exterior and, where possible, the interior of certain properties included in the attached valuation certificate. However, no structural survey has been made and we are therefore unable to report as to whether the properties are free from rot, infestation or any other structural defects. No tests were carried out on any of the services.

Having examined all relevant documentation, we have relied to a very considerable extent on the information provided by the Group and have accepted advice given to us by it on such matters as planning approvals, statutory notices, easements, tenure, occupation, rentals, site and floor areas and in the identification of those properties in which the Group has valid interests. We have had no reason to doubt the truth and accuracy of the information provided to us by the Group. We were also advised by the Group that no material factors have been omitted from the information to reach an informed view, and have no reason to suspect that any material information has been withheld.

No allowance has been made in our valuation for any charges, mortgages or amounts owing on any of the properties valued nor for any expenses or taxation which may be incurred in effecting a sale. Unless otherwise stated, it is assumed that all the interests are free of encumbrances, restrictions and outgoings of an onerous nature which could affect their values.

The market value estimate contained in this report specifically excludes the impact of structural damage or environmental contamination resulting from earthquakes or other causes. It is recommended that the reader of this report should consult a qualified structural engineer and/or environmental auditor for the evaluation of possible structural/environmental defects, the existence of which could have a material impact on market value.

**OPINION OF VALUE**

The capital values of the property interests are shown in the summary of valuation and valuation certificates of respective property interests.

**REMARKS**

Our valuation has been prepared in accordance with generally accepted valuation procedures including property inspections, enquiries, market information gathering, analysis and comparison and comply with the requirements of the Rules Governing the Listing of Securities on the Growth Enterprise Market of The Stock Exchange of Hong Kong Limited.

Unless otherwise stated, all money amounts stated in our valuations are in Hong Kong dollars. The exchange rate used in valuing the property interests in Group I and II is the average rate prevailing at the date of valuation, the details being summarized as follows:

<b>Country</b>	<b>Exchange Rate</b>
The PRC	HK\$1.00 = RMB1.06

There has been no significant fluctuation in exchange rate between the date of valuation and the date of this letter.

We enclose herewith the summary of valuation and valuation certificates.

This valuation report is issued subject to our General Service Conditions.

Yours faithfully,  
For and on behalf of  
**Greater China Appraisal Limited**  
**K. K. Ip**  
*BLE, MRICS, AHKIS, RPS(GP)*  
*Managing Director*

*Note:* Mr. K. K. Ip, who is a Chartered Valuation Surveyor and a Registered Professional Surveyor, has substantial experience in valuation of properties in Hong Kong and the PRC since 1992.

## SUMMARY OF VALUATION

Group I – Property interests owned and occupied by the Group  
in the People’s Republic of China

Property	Capital Value in Existing State to the Group as at 31st July, 2002 (HK\$)	Interest Attributable to the Group	Capital Value in Existing State Attributable to the Group as at 31st July, 2002 (HK\$)
1. 8th Floor and Units 01-03 and 05 on 9th Floor and Private Car Parking Spaces Nos. 17-19 on Basement Gao Jing Trade Centre No. 158 Wu Yi Bei Road Fuzhou City Fujian Province The PRC	10,000,000	100%	10,000,000
2. Unit B 17th Floor Jin Shan Building No. 862 Xia He Road Xiamen City Fujian Province The PRC	1,300,000	100%	1,300,000
		Sub-total:	11,300,000

## Group II – Property interests rented by the Group in the People’s Republic of China

Property	Capital Value in Existing State Attributable to the Group as at 31st July, 2002 (HK\$)
3. A parcel of Land with 2 Buildings and Various Structures Erected thereon No. 83 Zhan Jin Xiang Xian Feng Village Cang Shan Town Cang Shan District Fuzhou City Fujian Province The PRC	No Commercial Value
4. 1st Floor Pang Men Xi Yuan No. 10 Ma Lian Road Xuanwu District Beijing City The PRC	No Commercial Value
5. 1st Floor Situated at No. 123 Yan An San Road South District Qingdao City Shandong Province The PRC	No Commercial Value
6. Shop Nos. 3 and 4 1st Floor Block D Si He Plaza No. 298 Bin Jiang Zhong Road Nanping City Fujian Province The PRC	No Commercial Value
7. Unit 702 7th Floor Xing Ji Building No. 11 Tian An Road Fengze District Quanzhou City Fujian Province The PRC	No Commercial Value

Property	Capital Value in Existing State Attributable to the Group as at 31st July, 2002 (HK\$)
8. Units 212 and 213 2nd Floor Situating at No. 14 Gao Cang Street Rongcheng District Fuqing City Fujian Province The PRC	No Commercial Value
9. 2nd Floor Situating at No. 14-3 Yan Shan Dong Road Mawei District Fuzhou City Fujian Province The PRC	No Commercial Value
10. 1st Floor Hua Bao Garden No. 11 Dong Xi Er Lu Gong Lu Fen Ju Bian Street Shishi City Fujian Province The PRC	No Commercial Value
11. 4th Floor Block 4-1 Lian Hua Shan Xin Cun Xi Cheng Luo Long Road Xinluo District Longyan City Fujian Province The PRC	No Commercial Value
12. Portion of 1st Floor Fire Service Building No. 68 Xue Yuen Road Chengxiang District Poutian City Fujian Province The PRC	No Commercial Value

<b>Property</b>	<b>Capital Value in Existing State Attributable to the Group as at 31st July, 2002 (HK\$)</b>
13. Unit 203 2nd Floor Zhong Yun Building No. 14 Lan Tian Xin Cun Lan Tian Road Putuo District Shanghai City The PRC	No Commercial Value
14. Room 108 1st Floor Block 9-4 Tai He Yuan He Yan Road Xiaguan District Nanjing City Jiangsu Province The PRC	No Commercial Value
15. A Single-Storey Building Situated at No. 188 Hong Dao Bei Main Road Nanchang City Jiangxi Province The PRC	No Commercial Value
Sub-total:	No Commercial Value

**Group III – Property interests rented by the Group in Hong Kong**

<b>Property</b>	<b>Capital Value in Existing State Attributable to the Group as at 31st July, 2002 (HK\$)</b>
16. Units 506 and 507 Office B 5th Floor K. Wah Centre No. 191 Java Road North Point Hong Kong	No Commercial Value
Sub-total:	No Commercial Value
<b>GRAND-TOTAL:</b>	<b>11,300,000</b>

## VALUATION CERTIFICATE

Group I – Property interests owned and occupied by the Group  
in the People’s Republic of China

Property	Description and Tenure	Particulars of Occupancy	Capital Value in Existing State Attributable to the Group as at 31st July, 2002 (HK\$)
1. 8th Floor and Units 01-03 and 05 on 9th Floor and Private Car Parking Spaces Nos. 17-19 on Basement Gao Jing Trade Centre No. 158 Wu Yi Bei Road Fuzhou City Fujian Province The PRC	<p>The property comprises two office floors on the 8th and 9th floors of a 9-storey (plus one basement level) commercial building completed in mid to late 1990s, and three private car parking spaces on basement of that commercial building.</p> <p>The office floors have a total gross floor area of approximately 1,721.74 square metres (18,532.81 square feet) and the private car parking spaces have a total gross floor area of approximately 116.01 square metres (1,248.73 square feet).</p>	The property is currently occupied by the Group as head office and for private car parking use.	10,000,000

*Notes:*

- (1) According to the Sales and Purchase Contract (No. GF-2000-0171(MF-2000-No. 0110608)) entered into between Fujian Gaojing Real Estate Company Limited (“Party A”) and Fujian Wanyou Enterprises Group Limited (“Party B”), now known as Fujian Wanyou Fire Fighting Science and Technology Co., Ltd., a wholly-owned subsidiary of the Company, dated 18th March, 2000, the property of office floors was sold by Party A to Party B for a period of land use right of 50 years to be expired on 14th May, 2045 and for commercial use.

According to the Sales and Purchase Contract (No. GF-2000-0171(MF-2000-No. 0110613)) entered into between Fujian Gaojing Real Estate Company Limited (“Party A”) and Fujian Wanyou Enterprises Group Limited (“Party B”), now known as Fujian Wanyou Fire Fighting Science and Technology Co., Ltd., a wholly-owned subsidiary of the Company, dated 18th March, 2000, the property of private car parking spaces was sold by Party A to Party B for a period of land use right of 50 years to be expired on 14th May, 2045 and for commercial use.

- (2) As stipulated in the Building Ownership Certificate (Document No. 榕房權證R字第0203417號) issued by the 福州市房地產產權監理處 and dated 6th February, 2002, the current registered owner of the property of office floors is Fujian Wanyou Enterprises Group Limited, now known as Fujian Wanyou Fire Fighting Science and Technology Co., Ltd., a wholly-owned subsidiary of the Company.

As stipulated in the Building Ownership Certificate (Document No. 榕房權證R字第0203418號) issued by the 福州市房地產產權監理處 and dated 6th February, 2002, the current registered owner of the property of private car parking spaces is Fujian Wanyou Enterprises Group Limited, now known as Fujian Wanyou Fire Fighting Science and Technology Co., Ltd., a wholly-owned subsidiary of the Company.

- (3) According to a Property Collateral Loan Contract (No.2002C000478) dated 21st January, 2002 and registered to the 福州市房地產交易所, the property of office floors and private car parking spaces is subject to a mortgage loan in favour of Agricultural Bank of China, Fuzhou City, Hudong Branch, for a loan of RMB5,120,000 for a term of 7 years.

- (4) We have prepared our valuation on the assumption that the property is currently held by the Group which has the rights to occupy, use, sell, lease, charge, mortgage or otherwise dispose of the property within its respective term of land use rights granted by the government without the need to seek further approval from and paying any addition premium to the government.
- (5) The opinion of the Group's legal advisors on PRC law states, inter alia, that:
- (i) The owner of the property of office floors is Fujian Wanyou Enterprises Group Limited, now known as Fujian Wanyou Fire Fighting Science and Technology Co., Ltd.
  - (ii) The owner of the property of private car parking spaces is Fujian Wanyou Enterprises Group Limited, now known as Fujian Wanyou Fire Fighting Science and Technology Co., Ltd.
  - (iii) As stipulated in one State-owned Land Use Right Certificate (Document No.: 榕國用(1996)字第P05114號) dated 20th March, 1996 and issued to Fujian Gaojing Real Estate Company Limited for the land of No. 158 Wu Yi Bei Road, Fuzhou City, Fujian Province, the PRC, the land use right of the land is 50 years to be expired on 14th May, 2045 and for commercial use. Under the Sales and Purchase Contracts of the properties of office floors and private car parking spaces entered into between Fujian Gaojing Real Estate Company Limited ("Party A") and Fujian Wanyou Enterprises Group Limited ("Party B"), now known as Fujian Wanyou Fire Fighting Science and Technology Co., Ltd., Party A has assigned the land use right of the properties of office floors and private car parking spaces to Party B for a period of land use right of 50 years to be expired on 14th May, 2045 and for commercial use. Within the residual period of the land use right, the Group holds the legal title of the land use right and the properties of office floors and private car parking spaces erected thereon without further paying costs or premium. The Group has the legal right of assigning or transferring, mortgaging and leasing the whole property.
  - (iv) There is no onerous encumbrances against the whole property. All sum payable and all government approvals for obtaining the legal title to the whole property have been fully paid and obtained by the Group respectively.
  - (v) All contracts or agreements entered into by the Group are legally valid or enforceable.
- (6) The status of the title and grant of major approvals and licenses in accordance with the information provided to us by the Group and the opinion of the Group's PRC legal adviser are as follows:

<b>Documents</b>	<b>Status</b>
Sales and Purchase Contract (office floors)	Obtained
Sales and Purchase Contract (private car parking spaces)	Obtained
State-owned Land Use Right Certificate (office floors)	N/A
State-owned Land Use Right Certificate (private car parking spaces)	N/A
Building Ownership Certificate (office floors)	Obtained
Building Ownership Certificate (private car parking spaces)	Obtained



Property	Description and Tenure	Particulars of Occupancy	Capital Value in Existing State Attributable to the Group as at 31st July, 2002 (HK\$)
2. Unit B 17th Floor Jin Shan Building No. 862 Xia He Road Xiamen City Fujian Province The PRC	<p>The property comprises one office unit on the 17th floor of a 21-storey (plus two basement level) commercial building completed in mid to late 1990s.</p> <p>The gross floor area of the property is approximately 253.07 square metres (2,724.05 square feet).</p>	The property is currently occupied by the Group as branch office.	1,300,000

*Notes:*

- (1) According to a Sales and Purchase Contract (No. GF-2000-0171(0192046)) entered into between 北慶(廈門)房地產開發有限公司 (“Party A”) and Fujian Wanyou Fire Fighting Science and Technology Co., Ltd. (“Party B”), a wholly-owned subsidiary of the Company, dated 11th March, 2002, the property was sold by Party A to Party B for a period of land use right of 50 years to be expired on 18th July, 2043 and for commercial use.
- (2) We have prepared our valuation on the assumption that the property is currently held by the Group which has the rights to occupy, use, sell, lease, charge, mortgage or otherwise dispose of the property within its respective term of land use rights granted by the government without the need to seek further approval from and paying any addition premium to the government.
- (3) The opinion of the Group’s legal advisors on PRC law states, inter alia, that:
  - (i) The owner of the property is Fujian Wanyou Fire Fighting Science and Technology Co., Ltd., a wholly-owned subsidiary of the Company.
  - (ii) The Building Ownership Certificate is in the process of application and there is no legal obstacle to obtain the Building Ownership Certificate.
  - (iii) As stipulated in one State-owned Land Use Right Certificate (Document No.: 廈國用(97)字第052號) dated 14th March, 1997 and issued to 北慶(廈門)房地產開發有限公司 for the land of No. 862 Xia He Road, Xiamen City, Fujian Province, the PRC, the land use right of the land is 50 years to be expired on 18th July, 2043 and for commercial use. Under the Sales and Purchase Contract of the property entered into between 北慶(廈門)房地產開發有限公司 (“Party A”) and Fujian Wanyou Fire Fighting Science and Technology Co., Ltd. (“Party B”), Party A has assigned the land use right of the property to Party B for a period of land use right of 50 years to be expired on 18th July, 2043 and for commercial use. Within the residual period of the land use right, the Group holds the legal title of the land use right and the property erected thereon without further paying costs or premium. The Group has the legal right of assigning or transferring, mortgaging and leasing the whole property.
  - (iv) There is no onerous encumbrances against the whole property. All sum payable for obtaining the legal title to the whole property have been fully paid by the Group and save of Note(3)(ii), all government approvals for obtaining the legal title to the whole property have been obtained by the Group.
  - (v) All contracts or agreements entered into by the Group are legally valid or enforceable.
- (4) The status of the title and grant of major approvals and licenses in accordance with the information provided to us by the Group and the opinion of the Group’s PRC legal adviser are as follows:

Documents	Status
Sales and Purchase Contract	Obtained
State-owned Land Use Right Certificate	N/A
Building Ownership Certificate	No

**Group II – Property interests rented by the Group  
in the People’s Republic of China**

Property	Description and Tenure	Particulars of Occupancy	Capital Value in Existing State Attributable to the Group as at 31st July, 2002 (HK\$)
<p>3. A parcel of Land with 2 Buildings and Various Structures Erected thereon No. 83 Zhan Jin Xiang Xian Feng Village Cang Shan Town Cang Shan District Fuzhou City Fujian Province The PRC</p>	<p>The property comprises a parcel of land with 2 buildings and various structures erected thereon and completed in mid to late 1990s.</p> <p>These buildings and structures include a 3-storey building for production and storage, a 2-storey building for product research and development, a security room and 2 mini stores. The site has an area of approximately 1,271.7 square meters (13,688.58 square feet). The total gross floor area of these buildings is approximately 2,499.6 square meters (26,905.69 square feet).</p> <p>The property is held by the Group under a tenancy agreement for a term of 15 years commencing from 1st July, 2001 to 1st July, 2016 at a lump sum rental of RMB950,000 for the first 5 years and at a monthly rental of RMB15,833 thereon exclusive of public utilities</p>	<p>The property is currently occupied by the Group as production and storage, product research and development.</p>	No commercial value
<p>4. 1st Floor Pang Men Xi Yuan No. 10 Ma Lian Road Xuanwu District Beijing City The PRC</p>	<p>The property comprises one floor on the 1st floor within a 2-storey commercial building completed in mid to late 1990s.</p> <p>The gross floor area of the property is approximately 96 square metres (1,033.34 square feet).</p> <p>The property is held by the Group under a tenancy agreement for a term of 2 years commencing from 1st April, 2002 to 31st March, 2004 at a monthly rental of RMB1,200 inclusive of public utilities.</p>	<p>The property is currently occupied by the Group as sales office.</p>	No commercial value

Property	Description and Tenure	Particulars of Occupancy	Capital Value in Existing State Attributable to the Group as at 31st July, 2002 (HK\$)
5. 1st Floor Situated at No. 123 Yan An San Road South District Qingdao City Shandong Province The PRC	<p>The property comprises one floor on the 1st floor within a 8-storey commercial building completed in mid to late 1990s.</p> <p>The gross floor area of the property is approximately 46 square metres (495.14 square feet).</p> <p>The property is held by the Group under a tenancy agreement for a term of 1 year commencing from 25th December, 2001 to 24th December, 2002 at a monthly rental of RMB1,700 inclusive of public utilities.</p>	<p>The property is currently occupied by the Group as sales office.</p>	<p>No commercial value</p>
6. Shop Nos. 3 and 4 1st Floor Block D Si He Plaza No. 298 Bin Jiang Zhong Road Nanping City Fujian Province The PRC	<p>The property comprises two retail units on the 1st floor within a 16-storey commercial building completed in mid to late 1990s.</p> <p>The gross floor area of the property is approximately 96 square metres (1,033.34 square feet).</p> <p>The property is held by the Group under a tenancy agreement for a term of 2 years commencing from 1st April, 2002 to 31st March, 2004 at a monthly rental of RMB750 exclusive of management fees and public utilities.</p>	<p>The property is currently occupied by the Group as sales office</p>	<p>No commercial value</p>

Property	Description and Tenure	Particulars of Occupancy	Capital Value in Existing State Attributable to the Group as at 31st July, 2002 (HK\$)
7. Unit 702 7th Floor Xing Ji Building No. 11 Tian An Road Fengze District Quanzhou City Fujian Province The PRC	<p>The property comprises one office unit on the 7th floor within a 9-storey commercial building completed in mid to late 1990s.</p> <p>The gross floor area of the property is approximately 128 square metres (1,377.79 square feet).</p> <p>The property is held by the Group under a tenancy agreement for a term of 2 years commencing from 1st April, 2001 to 1st April, 2003 at a monthly rental of RMB1,200.</p>	The property is currently occupied by the Group as sales office.	No commercial value
8. Units 212 and 213 2nd Floor Situated at No. 14 Gao Cang Street Rongcheng District Fuqing City Fujian Province The PRC	<p>The property comprises two office units on the 2nd floor within a 2-storey residential/commercial building completed in mid to late 1990s.</p> <p>The gross floor area of the property is approximately 120 square metres (1,291.68 square feet).</p> <p>The property is held by the Group under a tenancy agreement for a term of 2 years commencing from 13th May, 2002 to 12th May, 2004 at a monthly rental of RMB800.</p>	The property is currently occupied by the Group as sales office.	No commercial value

Property	Description and Tenure	Particulars of Occupancy	Capital Value in Existing State Attributable to the Group as at 31st July, 2002 (HK\$)
9. 2nd Floor Situated at No. 14-3 Yan Shan Dong Road Mawei District Fuzhou City Fujian Province The PRC	<p>The property comprises one floor on the 2nd floor within a 10-storey residential/commercial building completed in mid to late 1990s.</p> <p>The gross floor area of the property is approximately 70 square metres (753.48 square feet).</p> <p>The property is held by the Group under a tenancy agreement for a term of 2 years commencing from 1st May, 2002 to 30th April, 2004 at a monthly rental of RMB500.</p>	<p>The property is currently occupied by the Group as sales office and for staff quarter use.</p>	No commercial value
10. 1st Floor Hua Bao Garden No. 11 Dong Xi Er Lu Gong Lu Fen Ju Bian Street Shishi City Fujian Province The PRC	<p>The property comprises one floor on the 1st floor within a 8-storey residential/commercial building completed in mid to late 1990s.</p> <p>The gross floor area of the property is approximately 70 square metres (753.48 square feet).</p> <p>The property is held by the Group under a tenancy agreement for a term of 5 years commencing from 5th November, 1999 to 5th November, 2004 at a monthly rental of RMB650.</p>	<p>The property is currently occupied by the Group as sales office.</p>	No commercial value

Property	Description and Tenure	Particulars of Occupancy	Capital Value in Existing State Attributable to the Group as at 31st July, 2002 (HK\$)
11. 4th Floor Block 4-1 Lian Hua Shan Xin Cun Xi Cheng Luo Long Road Xinluo District Longyan City Fujian Province The PRC	<p>The property comprises one floor on the 4th floor within a 6-storey residential/commercial building completed in mid to late 1990s.</p> <p>The useable floor area of the property is approximately 138 square metres (1,485.43 square feet).</p> <p>The property is held by the Group under a tenancy agreement for a term of 2 years commencing from 10th January, 2002 to 9th January, 2004 at an annual rental of RMB3,800.</p>	<p>The property is currently occupied by the Group as sales office.</p>	<p>No commercial value</p>
12. Portion of 1st Floor Fire Service Building No. 68 Xue Yuen Road Chengxiang District Poutian City Fujian Province The PRC	<p>The property comprises a portion of the 1st floor within a 15-storey fire service building completed in early 2000s.</p> <p>The gross floor area of the property is approximately 110 square metres (1,184.04 square feet).</p> <p>The property is held by the Group under a tenancy agreement for a term of 4 years commencing from 1st January, 2002 to 31st December, 2005 at a monthly rental of RMB1,000 inclusive of public utilities.</p>	<p>The property is currently occupied by the Group as sales office.</p>	<p>No commercial value</p>

Property	Description and Tenure	Particulars of Occupancy	Capital Value in Existing State Attributable to the Group as at 31st July, 2002 (HK\$)
13. Unit 203 2nd Floor Zhong Yun Building No. 14 Lan Tian Xin Cun Lan Tian Road Putuo District Shanghai City The PRC	<p>The property comprises one office unit on the 2nd floor within a 7-storey (plus one basement level) commercial building completed in mid to late 1990s.</p> <p>The gross floor area of the property is approximately 70 square metres (753.48 square feet).</p> <p>The property is held by the Group under a tenancy agreement for a term of 2 years commencing from 25th March, 2002 to 24th March, 2004 at a monthly rental of RMB1,800 inclusive of public utilities and free car parking space.</p>	<p>The property is currently occupied by the Group as sales office.</p>	<p>No commercial value</p>
14. Room 108 1st Floor Block 9-4 Tai He Yuan He Yan Road Xiaguan District Nanjing City Jiangsu Province The PRC	<p>The property comprises one office unit on the 1st floor within a 8-storey residential/commercial building completed in early 2000s.</p> <p>The gross floor area of the property is approximately 70 square metres (753.48 square feet).</p> <p>The property is held by the Group under a tenancy agreement for a term of 13 months commencing from 1st December, 2001 to 31st December, 2002 at a monthly rental of RMB400.</p>	<p>The property is currently occupied by the Group as sales office.</p>	<p>No commercial value</p>

<b>Property</b>	<b>Description and Tenure</b>	<b>Particulars of Occupancy</b>	<b>Capital Value in Existing State Attributable to the Group as at 31st July, 2002 (HK\$)</b>
15. A Single-Storey Building Situated at No. 188 Hong Dao Bei Main Road Nanchang City Jiangxi Province The PRC	<p>The property comprises one single-storey building for commercial use and completed in mid to late 1990s.</p> <p>The gross floor area of the property is approximately 150 square metres (1,614.6 square feet).</p> <p>The property is held by the Group under a tenancy agreement for a term of 2 years commencing from 21st March, 2002 to 20th March, 2004 at a monthly rental of RMB2,400.</p>	The property is currently occupied by the Group as sales office.	No commercial value

**Group III – Property interests rented by the Group in Hong Kong**

<b>Property</b>	<b>Description and Tenure</b>	<b>Particulars of Occupancy</b>	<b>Capital Value in Existing State Attributable to the Group as at 31st July, 2002 (HK\$)</b>
16. Units 506 and 507 Office B 5th Floor K. Wah Centre No. 191 Java Road North Point Hong Kong	<p>The property comprises two office units on the 5th floor within a 30-storey commercial building completed in 1991.</p> <p>The saleable floor area of the property is approximately 101.82 square metres (1,096 square feet).</p> <p>The property is held by the Group under a tenancy agreement for a term of one year commencing from 15th March, 2002 to 14th March, 2003 with a rent free period of one month from 15th March, 2002 to 14th April, 2002 at a monthly rental of HK\$15,250 exclusive of rates and management fees.</p>	The property is currently occupied by the Group as representative office in Hong Kong.	No commercial value



# APPENDIX III SUMMARY OF THE CONSTITUTION OF THE COMPANY AND CAYMAN ISLANDS COMPANY LAW

Set out below is a summary of certain provisions of the memorandum of association of the Company and the Articles and of certain aspects of the Cayman Islands company law.

The Company was incorporated in the Cayman Islands as an exempted company with limited liability on 3rd January 2002 under the Companies Law. The memorandum of association (the “Memorandum”) and the Articles comprise its constitution.

## 1. MEMORANDUM OF ASSOCIATION

- (a) The Memorandum states, inter alia, that the liability of members of the Company is limited to the amount, if any, for the time being unpaid on the Shares respectively held by them and that the objects for which the Company is established shall include acting as an investment company. The objects of the Company are set out in clause 3 of the Memorandum which is available for inspection at the address specified in paragraph “Documents available for inspection” in Appendix V to this prospectus. As an exempted company, the Company may not trade in the Cayman Islands with any person, firm or corporation except in furtherance of the business of the Company carried on outside the Cayman Islands.
- (b) The Company may by special resolution alter its Memorandum with respect to any objects, powers or other matters specified therein.

## 2. ARTICLES OF ASSOCIATION

The Articles were adopted on 12th July 2002. The following is a summary of certain provisions of the Articles:

### (a) Directors

#### (i) *Power to allot and issue shares and warrants*

Subject to the provisions of the Companies Law and the Memorandum and Articles and to any special rights conferred on the holders of any shares or class of shares, any share may be issued with or have attached thereto such rights, or such restrictions, whether with regard to dividend, voting, return of capital, or otherwise, as the Company may by ordinary resolution determine (or, in the absence of any such determination or so far as the same may not make specific provision, as the board may determine). Subject to the Companies Law, the rules of any Designated Stock Exchange (as defined in the Articles) and the Memorandum and Articles, any share may be issued on terms that, at the option of the Company or the holder thereof, they are liable to be redeemed.

The board may issue warrants conferring the right upon the holders thereof to subscribe for any class of shares or securities in the capital of the Company on such terms as it may from time to time determine.

Subject to the provisions of the Companies Law and the Articles and, where applicable, the rules of any Designated Stock Exchange (as defined in the Articles) and without prejudice to any special rights or restrictions for the time being attached

## **APPENDIX III SUMMARY OF THE CONSTITUTION OF THE COMPANY AND CAYMAN ISLANDS COMPANY LAW**

to any shares or any class of shares, all unissued shares in the Company shall be at the disposal of the board, which may offer, allot, grant options over or otherwise dispose of them to such persons, at such times, for such consideration and on such terms and conditions as it in its absolute discretion thinks fit, but so that no shares shall be issued at a discount.

Neither the Company nor the board shall be obliged, when making or granting any allotment of, offer of, option over or disposal of shares, to make, or make available, any such allotment, offer, option or shares to members or others with registered addresses in any particular territory or territories being a territory or territories where, in the absence of a registration statement or other special formalities, this would or might, in the opinion of the board, be unlawful or impracticable. Members affected as a result of the foregoing sentence shall not be, or be deemed to be, a separate class of members for any purpose whatsoever.

*(ii) Power to dispose of the assets of the Company or any subsidiary*

There are no specific provisions in the Articles relating to the disposal of the assets of the Company or any of its subsidiaries. The Directors may, however, exercise all powers and do all acts and things which may be exercised or done or approved by the Company and which are not required by the Articles or the Companies Law to be exercised or done by the Company in general meeting.

*(iii) Compensation or payments for loss of office*

Pursuant to the Articles, payments to any Director or past Director of any sum by way of compensation for loss of office or as consideration for or in connection with his retirement from office (not being a payment to which the Director is contractually entitled) must be approved by the Company in general meeting.

*(iv) Loans and provision of security for loans to Directors*

There are provisions in the Articles prohibiting the making of loans to Directors.

*(v) Disclosure of interests in contracts with the Company or any of its subsidiaries*

A Director may hold any other office or place of profit with the Company (except that of the auditor of the Company) in conjunction with his office of Director for such period and, subject to the Articles, upon such terms as the board may determine, and may be paid such extra remuneration therefor (whether by way of salary, commission, participation in profits or otherwise) in addition to any remuneration provided for by or pursuant to any other Articles. A Director may be or become a director or other officer of, or otherwise interested in, any company promoted by the Company or any other company in which the Company may be interested, and shall not be liable to account to the Company or the members for any remuneration, profits or other benefits received by him as a director, officer or member of, or from his interest in, such other company. Subject as otherwise provided by the Articles, the board may also cause the voting power conferred by the shares in any other company held or owned by the Company to be exercised in such manner in all respects as it

## **APPENDIX III SUMMARY OF THE CONSTITUTION OF THE COMPANY AND CAYMAN ISLANDS COMPANY LAW**

thinks fit, including the exercise thereof in favour of any resolution appointing the Directors or any of them to be directors or officers of such other company, or voting or providing for the payment of remuneration to the directors or officers of such other company.

Subject to the Companies Law and the Articles, no Director or proposed or intended Director shall be disqualified by his office from contracting with the Company, either with regard to his tenure of any office or place of profit or as vendor, purchaser or in any other manner whatsoever, nor shall any such contract or any other contract or arrangement in which any Director is in any way interested be liable to be avoided, nor shall any Director so contracting or being so interested be liable to account to the Company or the members for any remuneration, profit or other benefits realised by any such contract or arrangement by reason of such Director holding that office or the fiduciary relationship thereby established. A Director who to his knowledge is in any way, whether directly or indirectly, interested in a contract or arrangement or proposed contract or arrangement with the Company shall declare the nature of his interest at the meeting of the board at which the question of entering into the contract or arrangement is first taken into consideration, if he knows his interest then exists, or in any other case, at the first meeting of the board after he knows that he is or has become so interested.

A Director shall not vote (nor be counted in the quorum) on any resolution of the board in respect of any contract or arrangement or other proposal in which he is to his knowledge materially interested but this prohibition shall not apply to any of the following matters, namely:

- (aa) any contract or arrangement for giving of any security or indemnity to the Director in respect of money lent or obligations incurred or undertaken by him at the request of or for the benefit of the Company or any of its subsidiaries;
- (bb) any contract or arrangement for the giving by the Company of any security or indemnity to a third party in respect of a debt or obligation of the Company or any of its subsidiaries for which the Director has himself assumed responsibility in whole or in part whether alone or jointly under a guarantee or indemnity or by the giving of security;
- (cc) any contract or arrangement concerning an offer of shares or debentures or other securities of or by the Company or any other company which the Company may promote or be interested in for subscription or purchase, where the Director is or is to be interested as a participant in the underwriting or sub underwriting of the offer;
- (dd) any contract or arrangement in which the Director is interested in the same manner as other holders of shares or debentures or other securities of the Company or any of its subsidiaries by virtue only of his interest in shares or debentures or other securities of the Company;

## **APPENDIX III SUMMARY OF THE CONSTITUTION OF THE COMPANY AND CAYMAN ISLANDS COMPANY LAW**

- (ee) any contract or arrangement concerning any other company in which he is interested only, whether directly or indirectly, as an officer or executive or a shareholder other than a company in which the Director together with any of his associates (as defined by the rules, where applicable, of any Designated Stock Exchange (as defined in the Articles)) is beneficially interested in 5 per cent. or more of the issued shares or of the voting rights of any class of shares of such company (or of any third company through which his interest is derived); or
- (ff) any proposal concerning the adoption, modification or operation of a share option scheme, a pension fund or retirement, death, or disability benefits scheme or other arrangement which relates both to Directors and employees of the Company or of any of its subsidiaries and does not provide in respect of any Director as such any privilege or advantage not accorded to the employees to which such scheme or fund relates.

### *(vi) Remuneration*

The ordinary remuneration of the Directors shall from time to time be determined by the Company in general meeting, such sum (unless otherwise directed by the resolution by which it is voted) to be divided amongst the Directors in such proportions and in such manner as the board may agree or, failing agreement, equally, except that any Director holding office for part only of the period in respect of which the remuneration is payable shall only rank in such division in proportion to the time during such period for which he held office. The Directors shall also be entitled to be prepaid or repaid all travelling, hotel and incidental expenses reasonably expected to be incurred or incurred by them in attending any board meetings, committee meetings or general meetings or separate meetings of any class of shares or of debentures of the Company or otherwise in connection with the discharge of their duties as Directors.

Any Director who, by request, goes or resides abroad for any purpose of the Company or who performs services which in the opinion of the board go beyond the ordinary duties of a Director may be paid such extra remuneration (whether by way of salary, commission, participation in profits or otherwise) as the board may determine and such extra remuneration shall be in addition to or in substitution for any ordinary remuneration as a Director. An executive Director appointed to be a managing director, joint managing director, deputy managing director or other executive officer shall receive such remuneration (whether by way of salary, commission or participation in profits or otherwise or by all or any of those modes) and such other benefits (including pension and/or gratuity and/or other benefits on retirement) and allowances as the board may from time to time decide. Such remuneration may be either in addition to or in lieu of his remuneration as a Director.

The board may establish or concur or join with other companies (being subsidiary companies of the Company or companies with which it is associated in business) in establishing and making contributions out of the Company's monies to any schemes or funds for providing pensions, sickness or compassionate allowances, life assurance or other benefits for employees (which expression as used in this and the following paragraph shall include any Director or ex-Director who may hold or

## **APPENDIX III SUMMARY OF THE CONSTITUTION OF THE COMPANY AND CAYMAN ISLANDS COMPANY LAW**

have held any executive office or any office of profit with the Company or any of its subsidiaries) and ex-employees of the Company and their dependents or any class or classes of such persons.

The board may pay, enter into agreements to pay or make grants of revocable or irrevocable, and either subject or not subject to any terms or conditions, pensions or other benefits to employees and ex-employees and their dependents, or to any of such persons, including pensions or benefits additional to those, if any, to which such employees or ex-employees or their dependents are or may become entitled under any such scheme or fund as is mentioned in the previous paragraph. Any such pension or benefit may, as the board considers desirable, be granted to an employee either before and in anticipation of, or upon or at any time after, his actual retirement.

*(vii) Retirement, appointment and removal*

At each annual general meeting, one third of the Directors for the time being (or if their number is not a multiple of three, then the number nearest to but not greater than one third) will retire from office by rotation provided that no Director holding office as chairman and/or managing director shall be subject to retirement by rotation, or be taken into account in determining the number of Directors to retire. The Directors to retire in every year will be those who have been longest in office since their last re-election or appointment but as between persons who became or were last re-elected Directors on the same day those to retire will (unless they otherwise agree among themselves) be determined by lot. There are no provisions relating to retirement of Directors upon reaching any age limit.

The Directors shall have the power from time to time and at any time to appoint any person as a Director either to fill a casual vacancy on the board or as an addition to the existing board. Any Director so appointed shall hold office only until the next following annual general meeting of the Company and shall then be eligible for reelection. Neither a Director nor an alternate Director is required to hold any shares in the Company by way of qualification.

A Director may be removed by a special resolution of the Company before the expiration of his period of office (but without prejudice to any claim which such Director may have for damages for any breach of any contract between him and the Company) and may by ordinary resolution appoint another in his place. Unless otherwise determined by the Company in general meeting, the number of Directors shall not be less than two. There is no maximum number of Directors.

The office or director shall be vacated:

- (aa) if he resigns his office by notice in writing delivered to the Company at the registered office of the Company for the time being or tendered at a meeting of the Board whereupon the Board resolves to accept such resignation;
- (bb) becomes of unsound mind or dies;

## APPENDIX III SUMMARY OF THE CONSTITUTION OF THE COMPANY AND CAYMAN ISLANDS COMPANY LAW

- (cc) if, without special leave, he is absent from meetings of the board (unless an alternate director appointed by him attends) for six (6) consecutive months, and the board resolves that his office is vacated;
- (dd) if he becomes bankrupt or has a receiving order made against him or suspends payment or compounds with his creditors;
- (ee) if he is prohibited from being a director by law; and
- (ff) if he ceases to be a director by virtue of any provision of law or is removed from office pursuant to the Articles.

The board may from time to time appoint one or more of its body to be managing director, joint managing director, or deputy managing director or to hold any other employment or executive office with the Company for such period and upon such terms as the board may determine and the board may revoke or terminate any of such appointments. The board may delegate any of its powers, authorities and discretions to committees consisting of such Director or Directors and other persons as the board thinks fit, and it may from time to time revoke such delegation or revoke the appointment of and discharge any such committees either wholly or in part, and either as to persons or purposes, but every committee so formed shall, in the exercise of the powers, authorities and discretions so delegated, conform to any regulations that may from time to time be imposed upon it by the board.

### *(viii) Borrowing powers*

The board may exercise all the powers of the Company to raise or borrow money, to mortgage or charge all or any part of the undertaking, property and assets (present and future) and uncalled capital of the Company and, subject to the Companies Law, to issue debentures, bonds and other securities of the Company, whether outright or as collateral security for any debt, liability or obligation of the Company or of any third party.

### *(ix) Proceedings of the Board*

The board may meet for the despatch of business, adjourn and otherwise regulate their meetings as they think fit. Questions arising at any meeting shall be determined by a majority of votes. In the case of an equality of votes, the chairman of the meeting shall have an additional or casting vote.

### *(x) Register of Directors and Officers*

The Companies Law and the Articles provide that the Company is required to maintain at its registered office a register of directors and officers which is not available for inspection by the public. A copy of such register must be filed with the Registrar of Companies in the Cayman Islands and any change must be notified to the Registrar within 30 days of any change in such directors or officers.

## **APPENDIX III SUMMARY OF THE CONSTITUTION OF THE COMPANY AND CAYMAN ISLANDS COMPANY LAW**

### **(b) Alterations to constitutional documents**

The Articles may be rescinded, altered or amended by the Company in general meeting by special resolution. The Articles state that a special resolution shall be required to alter the provisions of the Memorandum, or to change the name of the Company.

### **(c) Alteration of capital**

The Company may from time to time by ordinary resolution in accordance with the relevant provisions of the Companies Law:

- (i) increase its capital by such sum, to be divided into shares of such amounts as the resolution shall prescribe;
- (ii) consolidate and divide all or any of its capital into shares of larger amount than its existing shares;
- (iii) divide its shares into several classes and without prejudice to any special rights previously conferred on the holders of existing shares as the directors may determine;
- (iv) sub-divide its shares or any of them into shares of smaller amount than is fixed by the Memorandum, subject nevertheless to the provisions of the Companies Law, and so that the resolution whereby any share is sub-divided may determine that, as between the holders of the shares resulting from such sub-division, one or more of the shares may have any such preferred or other special rights, over, or may have such deferred rights or be subject to any such restrictions as compared with the others as the Company has power to attach to unissued or Placing Shares; and
- (v) cancel any shares which, at the date of passing of the resolution, have not been taken, or agreed to be taken, by any person, and diminish the amount of its capital by the amount of the shares so cancelled.

The Company may subject to the provisions of the Companies Law reduce its share capital or share premium account or any capital redemption reserve or other undistributable reserve in any way by special resolution.

### **(d) Variation of rights of existing shares or classes of shares**

Subject to the Companies Law, all or any of the special rights attached to the shares or any class of shares may (unless otherwise provided for by the terms of issue of that class) be varied, modified or abrogated either with the consent in writing of the holders of not less than three-fourths in nominal value of the issued shares of that class or with the sanction of a special resolution passed at a separate general meeting of the holders of the shares of that class. To every such separate general meeting the provisions of the Articles relating to general meetings will mutatis mutandis apply, but so that the necessary quorum (other than at an adjourned meeting) shall be two persons holding or representing by proxy not less than one-third in nominal value of the issued shares of that class and at any adjourned

## **APPENDIX III SUMMARY OF THE CONSTITUTION OF THE COMPANY AND CAYMAN ISLANDS COMPANY LAW**

meeting two holders present in person or by proxy whatever the number of shares held by them shall be a quorum. Every holder of shares of the class shall be entitled on a poll to one vote for every such share held by him, and any holder of shares of the class present in person or by proxy may demand a poll.

The special rights conferred upon the holders of any shares or class of shares shall not, unless otherwise expressly provided in the rights attaching to the terms of issue of such shares, be deemed to be varied by the creation or issue of further shares ranking *pari passu* therewith.

### **(e) Special resolution – majority required**

Pursuant to the Articles, a special resolution of the Company must be passed by a majority of not less than three-fourths of the votes cast by such members as, being entitled so to do, vote in person or, in the case of such members as are corporations, by their duly authorised representatives or, where proxies are allowed, by proxy at a general meeting of which not less than 21 clear days' notice, specifying the intention to propose the resolution as a special resolution, has been duly given. Provided that, except in the case of an annual general meeting, if it is so agreed by a majority in number of the members having a right to attend and vote at such meeting, being a majority together holding not less than 95 per cent. in nominal value of the shares giving that right and, in the case of an annual general meeting, if so agreed by all Members entitled to attend and vote thereat, a resolution may be proposed and passed as a special resolution at a meeting of which less than 21 clear days' notice has been given.

A copy of any special resolution must be forwarded to the Registrar of Companies in the Cayman Islands within 15 days of being passed.

An ordinary resolution is defined in the Articles to mean a resolution passed by a simple majority of the votes of such members of the Company as, being entitled to do so, vote in person or, in the case of corporations, by their duly authorised representatives or, where proxies are allowed, by proxy at a general meeting held in accordance with the Articles.

### **(f) Voting rights (generally and on a poll) and right to demand a poll**

Subject to any special rights or restrictions as to voting for the time being attached to any shares by or in accordance with the Articles, at any general meeting on a show of hands, every member who is present in person or by proxy or being a corporation, is present by its duly authorised representative shall have one vote and on a poll every member present in person or by proxy or, in the case of a member being a corporation, by its duly authorised representative shall have one vote for every fully paid share of which he is the holder but so that no amount paid up or credited as paid up on a share in advance of calls or installments is treated for the foregoing purposes as paid up on the share. Notwithstanding anything contained in the Articles, where more than one proxy is appointed by a member which is a clearing house (or its nominees), each such proxy shall have one vote on a show of hands. On a poll, a member entitled to more than one vote need not use all his votes or cast all the votes he uses in the same way.



## **APPENDIX III SUMMARY OF THE CONSTITUTION OF THE COMPANY AND CAYMAN ISLANDS COMPANY LAW**

At any general meeting a resolution put to the vote of the meeting is to be decided on a show of hands unless (before or on the declaration of the result of the show of hands or on the withdrawal of any other demand for a poll) a poll is demanded by (i) the chairman of the meeting or (ii) at least three members present in person or, in the case of a member being a corporation, by its duly authorised representative or by proxy for the time being entitled to vote at the meeting or (iii) any member or members present in person or, in the case of a member being a corporation, by its duly authorised representative or by proxy and representing not less than one-tenth of the total voting rights of all the members having the right to vote at the meeting or (iv) a member or members present in person or, in the case of a member being a corporation, by its duly authorised representative or by proxy and holding shares in the Company conferring a right to vote at the meeting being shares on which an aggregate sum has been paid equal to not less than one-tenth of the total sum paid up on all the shares conferring that right.

If a recognised clearing house (or its nominee(s)) is a member of the Company it may authorise such person or persons as it thinks fit to act as its representative(s) at any meeting of the Company or at any meeting of any class of members of the Company provided that, if more than one person is so authorised, the authorisation shall specify the number and class of shares in respect of which each such person is so authorised. A person authorised pursuant to this provision shall be entitled to exercise the same rights and powers on behalf of the recognised clearing house (or its nominee(s)) as if such person was the registered holder of the shares of the Company held by the recognised clearing house (or its nominee(s)) including the right to vote individually on a show of hands.

### **(g) Requirements for annual general meetings**

An annual general meeting of the Company must be held in each year, other than the year of incorporation (within a period of not more than 15 months after the holding of the last preceding annual general meeting or a period of 18 months from the date of incorporation, unless a longer period would not infringe the rules of any Designated Stock Exchange (as defined in the Articles)) at such time and place as may be determined by the board.

### **(h) Accounts and audit**

The board shall cause true accounts to be kept of the sums of money received and expended by the Company, and the matters in respect of which such receipt and expenditure take place, and of the property, assets, credits and liabilities of the Company and of all other matters required by the Companies Law or necessary to give a true and fair view of the Company's affairs and to explain its transactions.

The accounting records shall be kept at the registered office or at such other place or places as the board decides and shall always be open to inspection by any Director. No member (other than a Director) shall have any right to inspect any accounting record or book or document of the Company except as conferred by law or authorised by the board or the Company in general meeting.

A copy of every balance sheet and profit and loss account (including every document required by law to be annexed thereto) which is to be laid before the Company at its general meeting, together with a printed copy of the Directors' report and a copy of the auditors'

## **APPENDIX III SUMMARY OF THE CONSTITUTION OF THE COMPANY AND CAYMAN ISLANDS COMPANY LAW**

report, shall not less than 21 days before the date of the meeting be sent to every person entitled to receive notices of general meetings of the Company under the provisions the Articles; however, subject to compliance with all applicable laws, including the rules of the Designated Stock Exchange (as defined in the Articles), the Company may send to such persons a summary financial statement derived from the Company's annual accounts and the directors' report instead provided that any such person may by notice in writing served on the Company, demand that the Company sends to him, in addition to a summary financial statement, a complete printed copy of the Company's annual financial statement and the directors' report thereon.

Auditors shall be appointed and the terms and tenure of such appointment and their duties at all times regulated in accordance with the provisions of the Articles. The remuneration of the auditors shall be fixed by the Company in general meeting or in such manner as the members may determine.

The financial statements of the Company shall be audited by the auditor in accordance with generally accepted auditing standards. The auditor shall make a written report thereon in accordance with generally accepted auditing standards and the report of the auditor shall be submitted to the members in general meeting. The generally accepted auditing standards referred to herein may be those of a country or jurisdiction other than the Cayman Islands. If so, the financial statements and the report of the auditor should disclose this fact and name such country or jurisdiction.

### **(i) Notices of meetings and business to be conducted thereat**

An annual general meeting and any extraordinary general meeting at which it is proposed to pass a special resolution shall (save as set out in sub-paragraph (e) above) be called by at least 21 clear days' notice in writing, and any other extraordinary general meeting shall be called by at least 14 clear days' notice (in each case exclusive of the day on which the notice is served or deemed to be served and of the day for which it is given). The notice must specify the time and place of the meeting and, in the case of special business, the general nature of that business. In addition notice of every general meeting shall be given to all members of the Company other than such as, under the provisions of the Articles or the terms of issue of the shares they hold, are not entitled to receive such notices from the Company, and also to the auditors for the time being of the Company.

Notwithstanding that a meeting of the Company is called by shorter notice than that mentioned above, it shall be deemed to have been duly called if it is so agreed:

- (i) in the case of a meeting called as an annual general meeting, by all members of the Company entitled to attend and vote thereat; and
- (ii) in the case of any other meeting, by a majority in number of the members having a right to attend and vote at the meeting, being a majority together holding not less than 95 per cent. in nominal value of the issued shares giving that right.

## **APPENDIX III SUMMARY OF THE CONSTITUTION OF THE COMPANY AND CAYMAN ISLANDS COMPANY LAW**

All business shall be deemed special that is transacted at an extraordinary general meeting and also all business shall be deemed special that is transacted at an annual general meeting with the exception of the following, which shall be deemed ordinary business:

- (aa) the declaration and sanctioning of dividends;
- (bb) the consideration and adoption of the accounts and balance sheet and the reports of the directors and the auditors;
- (cc) the election of directors in place of those retiring;
- (dd) the appointment of auditors and other officers;
- (ee) the fixing of the remuneration of the directors and of the auditors;
- (ff) the granting of any mandate or authority to the directors to offer, allot, grant options over or otherwise dispose of the unissued shares of the Company representing not more than 20 per cent. in nominal value of its existing issued share capital; and
- (gg) the granting of any mandate or authority to the directors to repurchase securities of the Company.

### **(j) Transfer of shares**

All transfers of shares may be effected by an instrument of transfer in the usual or common form (which may include such standard form of transfer as may be prescribed by the Designated Stock Exchange) or in such other form as the board may approve and which may be under hand or, if the transferor or transferee is a clearing house or its nominee(s), by hand or by machine imprinted signature or by such other manner of execution as the board may approve from time to time. The instrument of transfer shall be executed by or on behalf of the transferor and the transferee provided that the board may dispense with the execution of the instrument of transfer by the transferee in any case in which it thinks fit, in its discretion, to do so and the transferor shall be deemed to remain the holder of the share until the name of the transferee is entered in the register of members in respect thereof. The board may also resolve either generally or in any particular case, upon request by either the transferor or the transferee, to accept mechanically executed transfers.

The board in so far as permitted by any applicable law may, in its absolute discretion, at any time and from time to time transfer any share upon the principal register to any branch register or any share on any branch register to the principal register or any other branch register.

Unless the board otherwise agrees, no shares on the principal register shall be transferred to any branch register nor may shares on any branch register be transferred to the principal register or any other branch register. All transfers and other documents of title shall be lodged for registration and registered, in the case of shares on a branch register, at the relevant registration office and, in the case of shares on the principal register, at the registered office in the Cayman Islands or such other place at which the principal register is kept in accordance with the Companies Law.

## **APPENDIX III SUMMARY OF THE CONSTITUTION OF THE COMPANY AND CAYMAN ISLANDS COMPANY LAW**

The board may, in its absolute discretion, and without assigning any reason, refuse to register a transfer of any share (not being a fully paid up share) to a person of whom it does not approve or any share issued under any share incentive scheme for employees upon which a restriction on transfer imposed thereby still subsists, and it may also refuse to register any transfer of any share to more than four joint holders or any transfer of any share (not being a fully paid up share) on which the Company has a lien.

The board may decline to recognise any instrument of transfer unless a fee of such maximum sum as any Designated Stock Exchange (as defined in the Articles) may determine to be payable or such lesser sum as the Directors may from time to time require is paid to the Company in respect thereof, the instrument of transfer, if applicable, is properly stamped, is in respect of only one class of share and is lodged at the relevant registration office or registered office or such other place at which the principal register is kept accompanied by the relevant share certificate(s) and such other evidence as the board may reasonably require to show the right of the transferor to make the transfer (and if the instrument of transfer is executed by some other person on his behalf, the authority of that person so to do).

The registration of transfers may be suspended and the register closed on giving notice by advertisement in a relevant newspaper and, where applicable, any other newspapers in accordance with the requirements of any Designated Stock Exchange (as defined in the Articles), at such times and for such periods as the board may determine and either generally or in respect of any class of shares. The register of members shall not be closed for periods exceeding in the whole 30 days in any year.

### **(k) Power for the Company to purchase its own shares**

The Company is empowered by the Companies Law and the Articles to purchase its own Shares subject to certain restrictions and the Board may only exercise this power on behalf of the Company subject to any applicable requirements imposed from time to time by any Designated Stock Exchange.

### **(l) Power for any subsidiary of the Company to own shares in the Company**

There are no provisions in the Articles relating to ownership of shares in the Company by a subsidiary.

### **(m) Dividends and other methods of distribution**

Subject to the Companies Law, the Company in general meeting may declare dividends in any currency to be paid to the members but no dividend shall be declared in excess of the amount recommended by the board.

The Articles provide dividends may be declared and paid out of the profits of the Company, realised or unrealised, or from any reserve set aside from profits which the directors determine is no longer needed. With the sanction of an ordinary resolution dividends may also be declared and paid out of share premium account or any other fund or account which can be authorised for this purpose in accordance with the Companies Law.

Except in so far as the rights attaching to, or the terms of issue of, any share may otherwise provide, (i) all dividends shall be declared and paid according to the amounts paid up on the shares in respect whereof the dividend is paid but no amount paid up on a share in

## **APPENDIX III SUMMARY OF THE CONSTITUTION OF THE COMPANY AND CAYMAN ISLANDS COMPANY LAW**

advance of calls shall for this purpose be treated as paid up on the share and (ii) all dividends shall be apportioned and paid pro rata according to the amount paid up on the shares during any portion or portions of the period in respect of which the dividend is paid. The Directors may deduct from any dividend or other monies payable to any member or in respect of any shares all sums of money (if any) presently payable by him to the Company on account of calls or otherwise.

Whenever the board or the Company in general meeting has resolved that a dividend be paid or declared on the share capital of the Company, the board may further resolve either (a) that such dividend be satisfied wholly or in part in the form of an allotment of shares credited as fully paid up, provided that the shareholders entitled thereto will be entitled to elect to receive such dividend (or part thereof) in cash in lieu of such allotment, or (b) that shareholders entitled to such dividend will be entitled to elect to receive an allotment of shares credited as fully paid up in lieu of the whole or such part of the dividend as the board may think fit. The Company may also upon the recommendation of the board by an ordinary resolution resolve in respect of any one particular dividend of the Company that it may be satisfied wholly in the form of an allotment of shares credited as fully paid up without offering any right to shareholders to elect to receive such dividend in cash in lieu of such allotment.

Any dividend, interest or other sum payable in cash to the holder of shares may be paid by cheque or warrant sent through the post addressed to the holder at his registered address, or in the case of joint holders, addressed to the holder whose name stands first in the register of the Company in respect of the shares at his address as appearing in the register or addressed to such person and at such addresses as the holder or joint holders may in writing direct. Every such cheque or warrant shall, unless the holder or joint holders otherwise direct, be made payable to the order of the holder or, in the case of joint holders, to the order of the holder whose name stands first on the register in respect of such shares, and shall be sent at his or their risk and payment of the cheque or warrant by the bank on which it is drawn shall constitute a good discharge to the Company. Any one of two or more joint holders may give effectual receipts for any dividends or other moneys payable or property distributable in respect of the shares held by such joint holders.

Whenever the board or the Company in general meeting has resolved that a dividend be paid or declared the board may further resolve that such dividend be satisfied wholly or in part by the distribution of specific assets of any kind.

All dividends or bonuses unclaimed for one year after having been declared may be invested or otherwise made use of by the board for the benefit of the Company until claimed and the Company shall not be constituted a trustee in respect thereof. All dividends or bonuses unclaimed for six years after having been declared may be forfeited by the board and shall revert to the Company.

No dividend or other monies payable by the Company on or in respect of any share shall bear interest against the Company.

## **APPENDIX III SUMMARY OF THE CONSTITUTION OF THE COMPANY AND CAYMAN ISLANDS COMPANY LAW**

### **(n) Proxies**

Any member of the Company entitled to attend and vote at a meeting of the Company is entitled to appoint another person as his proxy to attend and vote instead of him. A member who is the holder of two or more shares may appoint more than one proxy to represent him and vote on his behalf at a general meeting of the Company or at a class meeting. A proxy need not be a member of the Company and shall be entitled to exercise the same powers on behalf of a member who is an individual and for whom he acts as proxy as such member could exercise. In addition, a proxy shall be entitled to exercise the same powers on behalf of a member which is a corporation and for which he acts as proxy as such member could exercise if it were an individual member. On a poll or on a show of hands, votes may be given either personally (or, in the case of a member being a corporation, by its duly authorised representative) or by proxy.

### **(o) Call on shares and forfeiture of shares**

Subject to the Articles and to the terms of allotment, the board may from time to time make such calls upon the members in respect of any monies unpaid on the shares held by them respectively (whether on account of the nominal value of the shares or by way of premium). A call may be made payable either in one lump sum or by installments. If the sum payable in respect of any call or instalment is not paid on or before the day appointed for payment thereof, the person or persons from whom the sum is due shall pay interest on the same at such rate not exceeding 20 per cent. per annum as the board may agree to accept from the day appointed for the payment thereof to the time of actual payment, but the board may waive payment of such interest wholly or in part. The board may, if it thinks fit, receive from any member willing to advance the same, either in money or money's worth, all or any part of the monies uncalled and unpaid or installments payable upon any shares held by him, and upon all or any of the monies so advanced the Company may pay interest at such rate (if any) as the board may decide.

If a member fails to pay any call on the day appointed for payment thereof, the board may serve not less than 14 clear days' notice on him requiring payment of so much of the call as is unpaid, together with any interest which may have accrued and which may still accrue up to the date of actual payment and stating that, in the event of non-payment at or before the time appointed, the shares in respect of which the call was made will be liable to be forfeited.

If the requirements of any such notice are not complied with, any share in respect of which the notice has been given may at any time thereafter, before the payment required by the notice has been made, be forfeited by a resolution of the board to that effect. Such forfeiture will include all dividends and bonuses declared in respect of the forfeited share and not actually paid before the forfeiture.

A person whose shares have been forfeited shall cease to be a member in respect of the forfeited shares but shall, notwithstanding, remain liable to pay to the Company all monies which, at the date of forfeiture, were payable by him to the Company in respect of the shares, together with (if the board shall in its discretion so require) interest thereon from the date of forfeiture until the date of actual payment at such rate not exceeding 20 per cent. per annum as the board determines.

## **APPENDIX III SUMMARY OF THE CONSTITUTION OF THE COMPANY AND CAYMAN ISLANDS COMPANY LAW**

### **(p) Inspection of register of members**

Pursuant to the Articles, the register and branch register of members shall be open to inspection for at least 2 hours on every business day by members without charge, or by any other person upon a maximum payment of HK\$2.50 or such lesser sum specified by the board at the registered office or such other place in the Cayman Islands at which the register is kept in accordance with the Companies Law or, upon a maximum payment of HK\$1.00 or such lesser sum specified by the board, at the Registration Office (as defined in the Articles), unless the register is closed in accordance with the Articles.

### **(q) Quorum for meetings and separate class meetings**

No business shall be transacted at any general meeting unless a quorum is present when the meeting proceeds to business, but the absence of a quorum shall not preclude the appointment of a chairman.

Save as otherwise provided by the Articles the quorum for a general meeting shall be two members present in person (or, in the case of a member being a corporation, by its duly authorised representative) or by proxy and entitled to vote. In respect of a separate class meeting (other than an adjourned meeting) convened to sanction the modification of class rights the necessary quorum shall be two persons holding or representing by proxy not less than one-third in nominal value of the issued shares of that class.

A corporation being a member shall be deemed for the purpose of the Articles to be present in person if represented by its duly authorised representative being the person appointed by resolution of the directors or other governing body of such corporation to act as its representative at the relevant general meeting of the Company or at any relevant general meeting of any class of members of the Company.

### **(r) Rights of the minorities in relation to fraud or oppression**

There are no provisions in the Articles relating to rights of minority shareholders in relation to fraud or oppression. However, certain remedies are available to shareholders of the Company under Cayman law, as summarised in paragraph 3(f) of this Appendix.

### **(s) Procedures on liquidation**

A resolution that the Company be wound up by the court or be wound up voluntarily shall be a special resolution.

Subject to any special rights, privileges or restrictions as to the distribution of available surplus assets on liquidation for the time being attached to any class or classes of shares (i) if the Company shall be wound up and the assets available for distribution amongst the members of the Company shall be more than sufficient to repay the whole of the capital paid up at the commencement of the winding up, the excess shall be distributed *pari passu* amongst such members in proportion to the amount paid up on the shares held by them respectively and (ii) if the Company shall be wound up and the assets available for distribution amongst the members as such shall be insufficient to repay the whole of the paid-up capital, such assets shall be distributed so that, as nearly as may be, the losses shall be borne by the members in proportion to the capital paid up, or which ought to have been paid up, at the commencement of the winding up on the shares held by them respectively.

## **APPENDIX III SUMMARY OF THE CONSTITUTION OF THE COMPANY AND CAYMAN ISLANDS COMPANY LAW**

If the Company shall be wound up (whether the liquidation is voluntary or by the court) the liquidator may, with the authority of a special resolution and any other sanction required by the Companies Law divide among the members in specie or kind the whole or any part of the assets of the Company whether the assets shall consist of property of one kind or shall consist of properties of different kinds and the liquidator may, for such purpose, set such value as he deems fair upon any one or more class or classes of property to be divided as aforesaid and may determine how such division shall be carried out as between the members or different classes of members. The liquidator may, with the like authority, vest any part of the assets in trustees upon such trusts for the benefit of members as the liquidator, with the like authority, shall think fit, but so that no contributory shall be compelled to accept any shares or other property in respect of which there is a liability.

### **(t) Untraceable members**

Pursuant to the Articles, the Company may sell any of the shares of a member who is untraceable if (i) all cheques or warrants (being not less than three in total number) for any sum payable in cash to the holder of such shares have remained uncashed for a period of 12 years; (ii) upon the expiry of the 12 year period, the Company has not during that time received any indication of the existence of the member; and (iii) the Company has caused an advertisement to be published in accordance with the rules of the Designated Stock Exchange (as defined in the Articles) giving notice of its intention to sell such shares and a period of three months, or such shorter period as may be permitted by the Designated Stock Exchange (as defined in the Articles), has elapsed since such advertisement and the Designated Stock Exchange (as defined in the Articles) has been notified of such intention. The net proceeds of any such sale shall belong to the Company and upon receipt by the Company of such net proceeds, it shall become indebted to the former member of the Company for an amount equal to such net proceeds.

### **(u) Subscription rights reserve**

The Articles provide that to the extent that it is not prohibited by and is in compliance with the Companies Law, if warrants to subscribe for shares have been issued by the Company and the Company does any act or engages in any transaction which would result in the subscription price of such warrants being reduced below the par value of a share, a subscription rights reserve shall be established and applied in paying up the difference between the subscription price and the par value of a share on any exercise of the warrants.

## **3. CAYMAN ISLANDS COMPANY LAW**

The Company is incorporated in the Cayman Islands subject to the Companies Law and, therefore, operates subject to the Cayman Islands law. Set out below is a summary of certain provisions of the Cayman Islands company law, although this does not purport to contain all applicable qualifications and exceptions or to be a complete review of all matters of the Cayman Islands company law and taxation, which may differ from equivalent provisions in jurisdictions with which interested parties may be more familiar:

### **(a) Operations**

As an exempted company, the Company's operations must be conducted mainly outside the Cayman Islands. The Company is required to file an annual return each year with the Registrar of Companies of the Cayman Islands and pay a fee which is based on the amount of its authorised share capital.



## **APPENDIX III SUMMARY OF THE CONSTITUTION OF THE COMPANY AND CAYMAN ISLANDS COMPANY LAW**

### **(b) Share capital**

The Companies Law provides that where a company issues shares at a premium, whether for cash or otherwise, a sum equal to the aggregate amount or value of the premiums on those shares shall be transferred to an account, to be called the “share premium account”. At the option of a company, these provisions may not apply to premiums or shares of that company allotted pursuant to any arrangement in consideration of the acquisition or cancellation of shares in any other company and issued at a premium. The Companies Law provides that the share premium account may be applied by the company subject to the provisions, if any, of its memorandum and articles of association in (a) paying distributions or dividends to members; (b) paying up unissued shares of the company to be issued to members as fully paid bonus shares; (c) in the redemption and repurchase of shares (subject to the provisions of section 37 of the Companies Law); (d) writing-off the preliminary expenses of the company; (e) writing-off the expenses of, or the commission paid or discount allowed on, any issue of shares or debentures of the company; and (f) providing for the premium payable on redemption or purchase of any shares or debentures of the company.

No distribution or dividend may be paid to members out of the share premium account unless immediately following the date on which the distribution or dividend is proposed to be paid the company will be able to pay its debts as they fall due in the ordinary course business.

The Companies Law provides that, subject to confirmation by the court, a company limited by shares or a company limited by guarantee and having a share capital may, if so authorised by its articles of association, by special resolution reduce its share capital in any way.

The Articles includes certain protections for holders of special classes of shares, requiring their consent to be obtained before their rights may be varied. The consent of the specified proportions of the holders of the issued shares of that class or the sanction of a resolution passed at a separate meeting of the holders of those shares is required.

### **(c) Financial assistance to purchase shares of a company or its holding company**

Subject to all applicable laws, the Company may give financial assistance to Directors and employees of the Company, its subsidiaries or any subsidiary of such holding company in order that they may buy Shares in the Company or shares in any subsidiary or holding company. Further, subject to all applicable laws, the Company may give financial assistance to a trustee for the acquisition of Shares in the Company or shares in any such subsidiary or holding company to be held for the benefit of employees of the Company, its subsidiaries, any holding company of the Company or any subsidiary of any such holding company (including salaried Directors).

There is no statutory restriction in the Cayman Islands on the provision of financial assistance by a company to another person for the purchase of, or subscription for, its own or its holding company’s shares. Accordingly, a company may provide financial assistance if the directors of the company consider, in discharging their duties of care and acting in good faith, for a proper purpose and in the interests of the company, that such assistance can properly be given. Such assistance should be on an arm’s-length basis.

## **APPENDIX III SUMMARY OF THE CONSTITUTION OF THE COMPANY AND CAYMAN ISLANDS COMPANY LAW**

### **(d) Purchase of shares and warrants by a company and its subsidiaries**

Subject to the provisions of the Companies Law, a company limited by shares or a company limited by guarantee and having a share capital may, if so authorised by its articles of association, issue shares which are to be redeemed or are liable to be redeemed at the option of the company or a shareholder. In addition, such a company may, if authorised to do so by its articles of association, purchase its own shares, including any redeemable shares. However, if the articles of association do not authorise the manner or purchase, a company cannot purchase any of its own shares unless the manner of purchase has first been authorised by an ordinary resolution of the company. At no time may a company redeem or purchase its shares unless they are fully paid. A company may not redeem or purchase any of its shares if, as a result of the redemption or purchase, there would no longer be any member of the company holding shares. A payment out of capital by a company for the redemption or purchase of its own shares is not lawful unless immediately following the date on which the payment is proposed to be made, the company shall be able to pay its debts as they fall due in the ordinary course of business.

A company is not prohibited from purchasing and may purchase its own warrants subject to and in accordance with the terms and conditions of the relevant warrant instrument or certificate. There is no requirement under Cayman Islands law that a company's memorandum or articles of association contain a specific provision enabling such purchases and the directors of a company may rely upon the general power contained in its memorandum of association to buy and sell and deal in personal property of all kinds.

Under Cayman Islands law, a subsidiary may hold shares in its holding company and, in certain circumstances, may acquire such shares.

### **(e) Dividends and distributions**

With the exception of section 34 of the Companies Law, there are no statutory provisions relating to the payment of dividends. Based upon English case law which is likely to be persuasive in the Cayman Islands, dividends may be paid only out of profits. In addition, section 34 of the Companies Law permits, subject to a solvency test and the provisions, if any, of the company's memorandum and articles of association, the payment of dividends and distributions out of the share premium account (see paragraph 2(m), above for further details).

### **(f) Protection of minorities**

The Cayman Islands courts ordinarily would be expected to follow English case law precedents which permit a minority shareholder to commence a representative action against or derivative actions in the name of the company to challenge (a) an act which is ultra vires the company or illegal, (b) an act which constitutes a fraud against the minority and the wrongdoers are themselves in control of the company, and (c) an irregularity in the passing of a resolution which requires a qualified (or special) majority.

In the case of a company (not being a bank) having a share capital divided into shares, the court may, on the application of members holding not less than one fifth of the shares of the company in issue, appoint an inspector to examine into the affairs of the company and to report thereon in such manner as the court shall direct.

## **APPENDIX III SUMMARY OF THE CONSTITUTION OF THE COMPANY AND CAYMAN ISLANDS COMPANY LAW**

Any shareholder of a company may petition the court which may make a winding up order if the court is of the opinion that it is just and equitable that the company should be wound up.

Generally claims against a company by its shareholders must be based on the general laws of contract or tort applicable in the Cayman Islands or their individual rights as shareholders as established by the Company's memorandum and articles of association.

### **(g) Management**

The Companies Law contains no specific restrictions on the power of directors to dispose of assets of a company. However, as a matter of general law, every officer of a company, which includes a director, managing director and secretary, in exercising his powers and discharging his duties must do so honestly and in good faith with a view to the best interests of the company and exercise the care, diligence and skill that a reasonably prudent person would exercise in comparable circumstances.

### **(h) Accounting and auditing requirements**

A company shall cause proper records of accounts to be kept with respect to (i) all sums of money received and expended by the company and the matters in respect of which the receipt and expenditure takes place; (ii) all sales and purchases of goods by the company and (iii) the assets and liabilities of the company.

Proper books of account shall not be deemed to be kept if there are not kept such books as are necessary to give a true and fair view of the state of the Company's affairs and to explain its transactions.

### **(i) Exchange control**

There are no exchange control regulations or currency restrictions in the Cayman Islands.

### **(j) Taxation**

Pursuant to section 6 of the Tax Concessions Law (1999 Revision) of the Cayman Islands, the Company has obtained an undertaking from the Governor-in- Council:

- (1) that no law which is enacted in the Cayman Islands imposing any tax to be levied on profits or income or gains or appreciation shall apply to the Company or its operations; and
- (2) that the aforesaid tax or any tax in the nature of estate duty or inheritance tax shall not be payable on the shares, debentures or other obligations of the Company.

The undertaking for the Company is for a period of twenty years from 15th January, 2002.

## **APPENDIX III SUMMARY OF THE CONSTITUTION OF THE COMPANY AND CAYMAN ISLANDS COMPANY LAW**

The Cayman Islands currently levy no taxes on individuals or corporations based upon profits, income, gains or appreciations and there is no taxation in the nature of inheritance tax or estate duty. There are no other taxes likely to be material to the Company levied by the Government of the Cayman Islands save certain stamp duties which may be applicable, from time to time, on certain instruments executed in or brought within the jurisdiction of the Cayman Islands. The Cayman Islands are not party to any double tax treaties.

### **(k) Stamp duty on transfers**

No stamp duty is payable in the Cayman Islands on transfers of shares of Cayman Islands companies except those which hold interests in land in the Cayman Islands.

### **(l) Loans to directors**

There is no express provision in the Companies Law prohibiting the making of loans by a company to any of its directors.

### **(m) Inspection of corporate records**

Members of the Company will have no general right under the Companies Law to inspect or obtain copies of the register of members or corporate records of the Company. They will, however, have such rights as may be set out in the Company's Articles.

An exempted company may, subject to the provisions of its articles of association, maintain its principal register of members and any branch registers at such locations, whether within or without the Cayman Islands, as the directors may, from time to time, think fit. There is no requirement under the Companies Law for an exempted company to make any returns of members to the Registrar of Companies in the Cayman Islands. The names and addresses of the members are, accordingly, not a matter of public record and are not available for public inspection.

### **(n) Winding up**

A company may be wound up by either an order of the court or by a special resolution of its members. The court also has authority to order winding up in a number of specified circumstances including where it is, in the opinion of the court, just and equitable that such company be wound up.

A company may be wound up voluntarily when the members so resolve in general meeting by special resolution, or, in the case of a limited duration company, when the period fixed for the duration of the company by its memorandum expires, or the event occurs on the occurrence of which the memorandum provides that the company is to be dissolved. In the case of a voluntary winding up, such company is obliged to cease to carry on its business from the time of passing the resolution for voluntary winding up or upon the expiry of the period or the occurrence of the event referred to above. Upon the appointment of a liquidator, the responsibility for the company's affairs rests entirely in his hands and no future executive action may be carried out without his approval.

## **APPENDIX III SUMMARY OF THE CONSTITUTION OF THE COMPANY AND CAYMAN ISLANDS COMPANY LAW**

A company is placed in liquidation either by an order of the court or by a special resolution of its members. A liquidator is appointed whose duties are to collect the assets of the company (including the amount (if any) due from the contributories), settle the list of creditors and discharge the company's liability to them, rateably if insufficient assets exist to discharge the liabilities in full, and to settle the list of contributories (shareholders) and divide the surplus assets (if any) amongst them in accordance with the rights attaching to the shares.

In the case of a members' voluntary winding up of a company, the company in general meeting must appoint one or more liquidators for the purpose of winding up the affairs of the company and distributing its assets.

As soon as the affairs of the company are fully wound up, the liquidator must make up an account of the winding up, showing how the winding up has been conducted and the property of the company has been disposed of, and thereupon call a general meeting of the company for the purposes of laying before it the account and giving an explanation thereof. This final general meeting shall be called by Public Notice or otherwise as the Registrar of Companies may direct.

For the purpose of conducting the proceedings in winding up a company and assisting the Court, there may be appointed one or more than one person to be called an official liquidator or official liquidator; and the Court may appoint to such office such person or persons, either provisionally or otherwise, as it thinks fit, and if more persons than one are appointed to such office, the Court shall declare whether any act hereby required or authorised to be done by the official liquidator is to be done by all or any one or more of given by an official liquidator on his appointment; if no official liquidator is appointed, or during any vacancy in such office, all the property of the company shall be in the custody of the Court.

### **(o) Reconstructions**

There are statutory provisions which facilitate reconstructions and amalgamations approved by a majority in number representing 75 per cent. in value of shareholders or creditors, depending on the circumstances, as are present at a meeting called for such purpose and thereafter sanctioned by the Courts. Whilst a dissenting shareholder would have the right to express to the Court his view that the transaction for which approval is sought would not provide the shareholders with a fair value for their shares, the Courts are unlikely to disapprove the transaction on that ground alone in the absence of evidence of fraud or bad faith on behalf of management and if the transactions were approved and consummated the dissenting shareholder would have no rights comparable to the appraisal rights (i.e. the right to receive payment in cash for the judicially determined value of their shares) ordinarily available, for example, to dissenting shareholders of a United States corporation.

### **(p) Take-overs**

Where an offer is made by a company for the shares of another company and, within four months of the offer, the holders of not less than 90 per cent. of the shares which are the subject of the offer accept, the offeror may at any time within two months after the expiration of the said four months, by notice require the dissenting shareholders to transfer their shares

## **APPENDIX III SUMMARY OF THE CONSTITUTION OF THE COMPANY AND CAYMAN ISLANDS COMPANY LAW**

on the terms of the offer. A dissenting shareholder may apply to the Court of the Cayman Islands within one month of the notice objecting to the transfer. The burden is on the dissenting shareholder to show that the Court should exercise its discretion, which it will be unlikely to do unless there is evidence of fraud or bad faith or collusion as between the offeror and the holders of the shares who have accepted the offer as a means of unfairly forcing out minority shareholders.

### **(q) Indemnification**

Cayman Islands law does not limit the extent to which a company's articles of association may provide for indemnification of officers and directors, except to the extent any such provision may be held by the court to be contrary to public policy (e.g. for purporting to provide indemnification against the consequences of committing a crime).

## **4. GENERAL**

Conyers Dill & Pearman, Cayman, the Company's special legal counsel on Cayman Islands law, have sent to the Company a letter of advice summarising certain aspects of Cayman Islands company law. This letter, together with a copy of the Companies Law, is available for inspection as referred to in the paragraph headed "Documents available for inspection" in Appendix V to this prospectus. Any person wishing to have a detailed summary of Cayman Islands company law or advice on the differences between it and the laws of any jurisdiction with which he is more familiar is recommended to seek independent legal advice.

**FURTHER INFORMATION ABOUT THE COMPANY****Incorporation**

The Company was incorporated in the Cayman Islands under the Companies Law as an exempted company with limited liability on 3rd January, 2002 with an authorised share capital of HK\$380,000 divided into 38,000,000 Shares. On 3rd January, 2002, pursuant to a resolution in writing passed by the subscriber of the Company, the nominal value of every Share was changed from HK\$0.01 to HK\$0.10 each such that the authorised share capital of the Company was HK\$380,000 divided into 3,800,000 shares of HK\$0.10 each. On 19th February, 2002, one Share of HK\$0.10 each was issued fully paid to Codan Trust Company (Cayman) Limited and subsequently transferred to Mr. Jiang Xiong on the same day.

On 11th March, 2002, pursuant to a resolution in writing passed by the sole shareholder of the Company, every issued and unissued share of HK\$0.10 each in the capital of the Company was subdivided (“Subdivision”) into 10 Shares of HK\$0.01 each such that the authorised share capital of the Company was HK\$380,000 divided into 38,000,000 shares of HK\$0.01 each and the issued share capital of the Company, being 1 share of HK\$0.10 each, was divided into 10 shares of HK\$0.01 each issued fully paid and held by Mr. Jiang Xiong.

The Company has established a place of business in Hong Kong at Units 6-7, Office B, 5th Floor, K. Wah Centre, No. 191 Java Road, North Point, Hong Kong. The Company was registered as an oversea company under Part XI of the Companies Ordinance on 27th May, 2002. In connection with such registration, Mr. Jiang Xiong of Flat 941, 9th Floor, Block D, Metropole Building, 416-430 King’s Road, North Point, Hong Kong and Mr. Chan Siu Tat of Room C, 14th Floor, 388 Des Voeux Road West, Hong Kong have been appointed as agents of the Company for acceptance of service of process and notices on behalf of the Company in Hong Kong.

As the Company is incorporated in the Cayman Islands and is subject to Cayman Islands company law, its constitution comprises a memorandum of association and Articles. A summary of certain relevant parts of the Company’s constitution and certain relevant aspects of the Cayman Islands company law is set out in Appendix III to this prospectus.

**Changes in share capital of the Company**

As at the date of incorporation of the Company, its authorised share capital was HK\$380,000 divided into 38,000,000 shares of a nominal value of HK\$0.01 each. On 3rd January, 2002, pursuant to a resolution in writing passed by the subscriber of the Company, the nominal value of every share of the Company was changed from HK\$0.01 to HK\$0.10 each, such that the authorised share capital of the Company was HK\$380,000 divided into 3,800,000 shares of HK\$0.10 each. On 19th February, 2002, the one subscriber share issued fully paid, in the share capital of the Company, was issued fully paid to Codan Trust Company (Cayman) Limited and subsequently transferred to Mr. Jiang Xiong on the same day.

As a result of the Subdivision on 11th March, 2002, the authorised share capital of the Company became HK\$380,000 divided into 38,000,000 Shares of HK\$0.01 each, and then the issued share capital of the Company comprised 10 shares of HK\$0.01 each, all of which were fully paid and held by Mr. Jiang Xiong.

On 12th July, 2002, the authorised share capital of the Company was increased from HK\$380,000 to HK\$100,000,000 by the creation of an additional 9,962,000,000 Shares.

On 20th September, 2002, in accordance with the agreement dated 20th September, 2002 in relation to the sale and purchase of shares in Wang Sing referred to in the paragraph headed “Summary of material contracts” in this appendix, the Company acquired from Mr. Jiang Xiong, Cantus, YMW and Morita (together, the “Existing Shareholders”), the entire issued share capital of Wang Sing and in consideration thereof, an aggregate of 1,599,999,990 Shares, credited as fully paid up, were allotted and issued to the Existing Shareholders in the proportion of 1,381,599,990 Shares to Mr. Jiang Xiong, 160,000,000 Shares to Cantus, 35,040,000 Shares to YMW and 23,360,000 Shares to Morita.

Immediately following the completion of the Placing, the authorised share capital of the Company will be HK\$100,000,000 divided into 10,000,000,000 Shares and the issued share capital will be HK\$20,000,000 divided into 2,000,000,000 Shares (each of which will be fully paid or credited as fully paid) and 8,000,000,000 Shares will remain unissued. Other than the New Shares issuable under the Placing and any Shares issuable pursuant to the exercise of the Over-allotment Option or any options granted under the Share Option Scheme, or the exercise of the general mandate referred to in the paragraph headed “Written resolutions of the sole shareholder of the Company passed on 12th July, 2002 and 20th September, 2002” of this appendix, the Directors have no present intention to issue any part of the authorised but unissued capital of the Company, and without the prior approval of the members of the Company in general meeting, no issue of Shares will be made which would effectively alter the control of the Company.

Save as disclosed in this prospectus, there has been no alteration in the share capital of the Company since its incorporation.

#### **Written resolutions of the sole shareholder of the Company passed on 12th July, 2002 and 20th September, 2002**

Pursuant to the written resolutions of the sole shareholder of the Company passed on 12th July, 2002, the following resolutions, among others, were passed:

- (a) the authorised share capital of the Company was increased from HK\$380,000 to HK\$100,000,000 by the creation of an additional 9,962,000,000 Shares; and
- (b) the Company adopted the Articles in substitution for and to the exclusion of the then existing Articles.

Pursuant to the written resolutions of the sole shareholder of the Company passed on 20th September, 2002:

- (a) in consideration for the acquisition by the Company of 10,000 shares of US\$1.00 each in the share capital of Wang Sing, representing its entire issued share capital, pursuant to an agreement between the Company as purchaser and the Existing Shareholders as vendors, relating to the sale and purchase of shares in Wang Sing, referred to in the paragraph headed “Summary of material contracts” in this appendix, the Directors were authorised to allot and issue an aggregate of 1,599,999,990 Shares, credited as fully paid up, to the Existing Shareholders (or as they may direct);
- (b) conditional on the GEM Listing Committee of the Stock Exchange granting approval of the listing of, and permission to deal in, the Shares in issue and the Shares to be issued (including any Shares which may be issued pursuant to the Placing or the exercise of the Over-allotment Option or any options which may be granted under the Share Option Scheme), and the obligations of the Underwriters under the Underwriting Agreement becoming unconditional (including, if relevant, as a result of the waiver



of any conditions(s) by CPY International and ICEA (for themselves and on behalf of the Underwriters), and not being terminated in accordance with the terms of that agreement or otherwise:–

- (i) the Placing upon the terms set out in this prospectus was approved subject to such modifications as may be decided by the Directors or any committee thereof duly appointed for such purpose and the Directors or any such committee was authorised to allot and issue the Shares pursuant thereto;
  - (ii) the grant of the Over-allotment Option was approved and the Directors or any committee thereof were authorised to allot and issue any Shares which may be required to be issued if the Over-allotment Option is exercised upon the terms set out in this prospectus and the Underwriting Agreement; and
  - (iii) the rules of the Share Option Scheme was approved and adopted and the Directors were authorised to grant options to subscribe for Shares thereunder, and to allot, issue and deal with Shares pursuant to the exercise of any options which may be granted under the Share Option Scheme and to take all such steps as they consider necessary or desirable to implement the Share Option Scheme;
- (c) a general unconditional mandate was given to the Directors during the Relevant Period (as defined below) to exercise all the powers of the Company to allot, issue and deal with Shares or securities convertible into such Shares in the unissued share capital of the Company including all powers of the Company to establish any agreements or grant any options to do any of the foregoing, otherwise than by way of rights issue or an issue of shares or any scrip dividend schemes or similar arrangements providing for the allotment and issue of Shares in accordance with the Articles or pursuant to the exercise of any subscription or conversion rights attaching to any warrants or any securities which are convertible into Shares in issue prior to the date of this resolution or pursuant to the exercise of any options which may be granted under the Share Option Scheme or any other option scheme, such Shares with an aggregate nominal value not exceeding the sum of 20 per cent. of the total nominal value of the share capital of the Company in issue immediately after the completion of the Placing and if applicable, which may be issued pursuant to the exercise of the Over-allotment Option, such general unconditional mandate to remain in effect until whichever is the earliest of:
- (i) the conclusion of the next annual general meeting of the Company;
  - (ii) the expiration of the period within which the next annual general meeting of the Company is required by the Articles or any applicable laws of the Cayman Islands to be held; or
  - (iii) the passing of an ordinary resolution of the shareholders of the Company in general meeting revoking, varying or renewing such mandate (the “Relevant Period”);
- (d) a general unconditional mandate was given to the Directors during the Relevant Period to exercise all the powers of the Company to repurchase on the Stock Exchange, or on any other stock exchange on which the securities of the Company may be listed and which is recognised by the Securities and Futures Commission in Hong Kong and

the Stock Exchange, subject to and in accordance with all applicable laws and/or requirements of the GEM Listing Rules or of any other stock exchange on which the securities of the Company may be listed as amended from time to time and which is recognised by the Securities and Futures Commission in Hong Kong and the Stock Exchange for this purpose, the aggregate nominal amount of Shares to be purchased by the Company shall not exceed 10 per cent. of the total nominal amount of the share capital of the Company in issue immediately following completion of the Placing and if applicable, which may be issued pursuant to the exercise of the Over-allotment Option; and

- (e) the general unconditional mandate mentioned in resolution (c) above was extended by the addition thereto of the aggregate nominal value of the share capital of the Company which may be allotted or agreed conditionally or unconditionally to be allotted by the Directors pursuant to such general mandate of an amount representing the aggregate nominal value of the share capital of the Company repurchased by the Company pursuant to the mandate to repurchase Shares referred to in resolution (d) above provided that such extended amount shall not exceed 10 per cent. of the total nominal value of the share capital of the Company in issue immediately following completion of the Placing (including the number of Shares which may be issued pursuant to the exercise of the Over-allotment Option if applicable).

### Corporate reorganisation

The companies comprising the Group underwent a reorganisation to rationalise the structure of the Group in preparation for the listing of the Shares on GEM. The reorganisation involved the following:

- (a) On 16th August, 2001, Mr. Jiang Qing (as transferee) entered into share transfer contracts with each of Mr. Chen Shu Quan, Mr. Zheng Ming Qiang and Mr. Li Li (as transferors) respectively, pursuant to which the transferors agreed to transfer their respective equity interests in Fujian Wanyou to Mr. Jiang Qing at the respective consideration of RMB150,000, RMB50,000 and RMB50,000, such that after the transfers, Mr. Jiang Qing held 3% equity interest in Fujian Wanyou and the remaining 97% shareholding interest was held by Mr. Jiang Xiong;
- (b) On 16th November, 2001, Fujian Wanyou declared a dividend of RMB34 million (equivalent to approximately HK\$32 million) of which RMB32.98 million was payable to Mr. Jiang Xiong and RMB1.02 million was payable to Mr. Jiang Qing. As at 18th November, 2001, an amount of RMB8.148 million was payable to Mr. Jiang Xiong by Fujian Wanyou in its current account. On 20th December, 2001, an assignment was entered into by Mr. Jiang Xiong, Wang Sing and Fujian Wanyou, whereby Mr. Jiang Xiong assigned to Wang Sing the amount due to him referred to in this paragraph from Fujian Wanyou at an aggregate consideration of RMB2 in order to contribute for the cost of investment in Wang Sing. On the other hand, the cost of purchase of Fujian Wanyou and Wanyou Engineering by Wang Sing, amounting to HK\$38.8 million, has been paid in full on 5th March, 2002.
- (c) On 18th November, 2001, a share transfer contract was entered into between Mr. Jiang Xiong and Mr. Jiang Qing (as transferors) and Wang Sing (as transferee, a company wholly and beneficially owned by Mr. Jiang Xiong) pursuant to which the transferors agreed to transfer their respective shareholding interests in Fujian Wanyou (representing the entire interests in the registered capital of Fujian Wanyou) to Wang

Sing at the respective consideration of HK\$38,800,000 and HK\$1,200,000, which was based on the net asset value of Fujian Wanyou. This was carried out by way of acquisition in light of the common practice in the PRC;

- (d) On 14th December, 2001, following the transfers referred to in (c) above, an approval was issued by the Foreign Trade Economic Cooperation Committee of Fujian Province 《福建省對外經濟貿易委員會》 approving the establishment of Fujian Wanyou as a wholly foreign-owned enterprise with a total authorised and registered capital of HK\$10,500,000, and Fujian Wanyou became a wholly-owned subsidiary of Wang Sing;
- (e) On 26th February, 2002, Mr. Jiang Xiong subscribed for 8,634 shares of US\$1.00 each in Wang Sing for cash at par and held, after the subscription, in aggregate 8,635 shares of Wang Sing, being its entire issued share capital. At the time of the subscription for shares in Wang Sing, Mr. Jiang Xiong did not have sufficient foreign currency amounting to HK\$38.8 million to subscribe for shares in Wang Sing which were at a value equivalent to the consideration for the disposal of his interest in Fujian Wanyou. Mr. Jiang Xiong's financial resources were in Renminbi and rested mainly in Fujian, the PRC. Due to the restriction of foreign exchange remittance in the PRC, Mr. Jiang Xiong was unable to remit such an amount of cash in foreign currency outside the PRC. The shares in Wang Sing were therefore issued to Mr. Jiang Xiong at par.
- (f) On 27th February, 2002, Wang Sing and Mr. Jiang Xiong entered into three separate subscription agreements with each of Cantus, YMW and Morita respectively. Pursuant to a share subscription agreement entered into between Wang Sing, Cantus and Mr. Jiang Xiong, Cantus subscribed for 1,000 shares in Wang Sing at a total consideration of approximately HK\$40,000,000, which was payable in cash. Pursuant to a subscription agreement entered into between Wang Sing, YMW and Mr. Jiang Xiong, YMW subscribed for 219 shares in Wang Sing at a total consideration of approximately HK\$8,745,900, which was payable in cash. Pursuant to a subscription agreement entered into between Wang Sing, Morita and Mr. Jiang Xiong, Morita subscribed for 146 shares in Wang Sing at a total consideration of approximately HK\$5,830,600, which was payable in cash.

After the completion of the above subscription agreements, Wang Sing is wholly and beneficially owned by Mr. Jiang Xiong (as to 8,635 shares), Cantus (as to 1,000 shares), YMW (as to 219 shares) and Morita (as to 146 shares).

- (g) On 20th September, 2002, pursuant to an agreement dated 20th September, 2002 entered into between the Company as purchaser and the Existing Shareholders as vendors in relation to the sale and purchase of shares in Wang Sing, the Existing Shareholders transferred all their shareholdings in Wang Sing, being the entire issued share capital of Wang Sing, to the Company and the Company, in return, allotted and issued an aggregate of 1,599,999,990 Shares, credited as fully paid up, to the Existing Shareholders in the proportion of 1,381,599,990 Shares to Mr. Jiang Xiong, 160,000,000 Shares to Cantus, 35,040,000 Shares to YMW and 23,360,000 Shares to Morita respectively.
- (h) In respect of the settlement of the amount due from Fujian Wanyou to Wang Sing resulting from the restructuring set out in paragraph (b) above, Fujian Wanyou has

resolved to pay a dividend of approximately RMB32.98 million and settle the current account of approximately RMB8.14 million, the total amount being equivalent to approximately HK\$38.8 million, to/with Wang Sing. Fujian Wanyou has applied to State Administration of Foreign Exchange, Fujian Province Office (“SAFE”) for approval in respect of the swapping of foreign exchange. The Company has obtained the acknowledgement from SAFE that the application is under process and the Directors expect this process to be completed by the end of this year. In addition, Chen & Co, the Company’s PRC legal advisers, has opined that such application complied with the relevant regulations in the PRC.

- (i) On 23rd July, 2002, the authorised share capital of Wang Sing was increased from US\$50,000 to US\$10,000,000 by the creation of an additional 9,950,000 shares of US\$1.00 each in capital of Wang Sing. Upon completion of the shares swapped referred to in (g) above, on 20th September, 2002 the Company capitalised, by way of capitalisation issue, all the retained earnings of approximately of HK\$38.8 million in the books of Wang Sing arising from the assignment referred to in (b) above and issue 4,974,359 shares of US\$1.00 each at par in Wang Sing to the Company.

#### **Changes in the share capital of subsidiaries**

The Company’s subsidiaries are referred to in the accountants’ report, the text of which is set out in Appendix I to this prospectus.

In addition to those disclosed in the paragraphs headed “Changes in share capital of the Company” and “Corporate reorganisation” of this appendix, the following alterations in the share capital of the Company’s subsidiaries also took place within the two years preceding the date of this prospectus:

##### *Wang Sing*

On 12th October, 2000, Wang Sing was incorporated in the BVI as an International Business Company with an authorised share capital of US\$50,000 divided into 50,000 shares of US\$1.00 each.

On 16th October, 2001, Mr. Jiang Xiong subscribed for 1 share of US\$1.00 each in Wang Sing.

On 26th February, 2002, Mr. Jiang Xiong subscribed for 8,634 shares in Wang Sing for cash at par.

Pursuant to three subscription agreements all dated 27th February, 2002, Cantus, YMW and Morita subscribed for 1,000 shares, 219 shares and 146 shares in Wang Sing respectively for a total consideration of approximately HK\$40,000,000, HK\$8,745,900 and HK\$5,830,600 in cash respectively.

Upon completion of the subscription described above, Wang Sing was owned as to 86.35% by Mr. Jiang Xiong, 10.00% by Cantus, 2.19% by YMW and 1.46% by Morita.

On 23rd July, 2002, the authorised share capital of Wang Sing was increased from US\$50,000 to US\$10,000,000 by the creation of an additional 9,950,000 shares of US\$1.00 each in capital of Wang Sing. Upon completion of the shares swap referred to in paragraph (g) in the section headed “Corporate reorganisation” in this appendix, on 20th September, 2002, the Company capitalised, by way of capitalisation issue, all the retained earnings of approximately of HK\$38.8 million in the books of Wang Sing arising from the assignment referred to in paragraph (b) in the paragraph headed “Corporate reorganisation” in this appendix and issue 4,974,359 shares of US\$1.00 each in Wang Sing to the Company.

#### *Fujian Wanyou*

For changes in the share capital of Fujian Wanyou, please refer to paragraphs (a) to (d) in the paragraph headed “Corporate reorganisation” in this appendix.

#### *Wanyou Engineering*

On 12th March, 2001, Mr. Jiang Qing acquired from Fujian Wanan its 31.19% equity interest in Wanyou Engineering (the remaining 68.81% equity interest in Wanyou Engineering was being held by Fujian Wanyou at that time) at a consideration of RMB1,579,100. On the same date, Fujian Wanyou increased its investment in Wanyou Engineering by RMB2,000,000, and the registered capital of Wanyou Engineering was therefore increased from RMB5,063,600 to RMB7,063,600.

Upon completion of the acquisition and increase in investment referred to above, Wanyou Engineering was owned as to 77.64% by Fujian Wanyou and 22.36% by Mr. Jiang Qing.

On 28th March, 2001, Mr. Jiang Qing sold his entire 22.36% equity interest in Wanyou Engineering to Fujian Wanyou and Liu Mei Jin, an independent third party, in the proportion of 21.36% to Fujian Wanyou and 1% to Liu Mei Jin, at the respective consideration of RMB18,000,000 and RMB70,600 in cash.

Upon completion of the acquisition, Wanyou Engineering was owned as to 99% by Fujian Wanyou and 1% by the independent third party, Liu Mei Jin.

#### *US Wanyou*

On 5th March, 2002, US Wanyou was incorporated in the State of Delaware, United States having authority to issue 1,500 shares of US\$1.00 each. On 7th March, 2002, Wang Sing subscribed for 1 share of US\$1.00 each in US Wanyou.

Save as disclosed in this prospectus, there has been no alteration in the share capital of the Company’s subsidiaries within the two years immediately preceding the date of this prospectus.

### **REPURCHASE BY THE COMPANY OF ITS OWN SECURITIES**

This section includes the information required by the Stock Exchange to be included in this prospectus concerning the repurchase by the Company of its own securities.

(a) **The GEM Listing Rules**

The GEM Listing Rules permit companies whose primary listing is on GEM to repurchase their securities on GEM subject to certain restrictions which are set out in Rules 13.03 – 13.14 of the GEM Listing Rules the most important of which are summarised below:

(i) *Shareholders' approval*

All repurchases of securities on GEM by a company with its primary listing on GEM must be approved in advance by an ordinary resolution of the shareholders, either by way of general mandate or by specific approval in relation to a specific transaction.

*Note:* Pursuant to the written resolution of the sole shareholder of the Company passed on 20th September, 2002, a general unconditional mandate was given to the Directors authorising any repurchase by the Company of Shares on GEM or on any other stock exchange recognised by the Securities and Futures Commission in Hong Kong and the Stock Exchange of up to 10 per cent. of the total nominal value of the share capital of the Company in issue immediately after completion of the Placing, at any time until the conclusion of the next annual general meeting of the Company or the expiration of the period within which the next annual general meeting of the Company is required by the Articles or the Companies Law or any other applicable laws of the Cayman Islands to be held or the passing of an ordinary resolution of the shareholders of the Company in general meeting revoking, varying or renewing such mandate, whichever occurs first (“Buyback Mandate”).

(ii) *Source of funds*

Any repurchases must be financed out of funds legally available for the purpose in accordance with the memorandum of association and articles of association of the company or equivalent constitutional documents and the applicable laws of its place of incorporation.

(iii) *Trading restrictions*

A company is authorised to repurchase on GEM or on any other stock exchange recognised by the Securities and Futures Commission in Hong Kong and the Stock Exchange the total number of shares which represent up to a maximum of 10 per cent. of the aggregate nominal value of the existing issued share capital of that company or warrants to subscribe for shares in the company representing up to 10% of the amount of warrants then outstanding at the date of passing of the relevant resolution granting the repurchase mandate. A company may not issue or announce an issue of new securities of the type that have been repurchased for a period of 30 days immediately following a repurchase of securities whether on GEM or otherwise (except pursuant to the exercise of warrants, share options or similar instruments requiring the company to issue securities which were outstanding prior to the repurchase) without the prior approval of the Stock Exchange. A company is also prohibited from making securities repurchases on GEM if the result of the repurchases would be that the number of the listed securities in public hands would be below the relevant prescribed minimum percentage for that company as determined by the Stock Exchange. The GEM Listing Rules further prohibit a company from purchasing its own Shares on GEM for a consideration other than cash or for settlement otherwise than in accordance with the trading rules of the Stock Exchange from time to time. A company may only purchase shares on GEM if the following restrictions as to price

and timing are adhered to (1) the purchase price should not be higher than the latest (or current) independent bid price or the last independent sale (contract) price quoted or reported on the system (as defined in the Rules of the Stock Exchange), whichever is higher; and (2) the company shall not make the opening bid nor any bid in the last 30 minutes before the close of normal trading hours as stipulated in the Rules of the Stock Exchange.

*(iv) Status of repurchased securities*

The listing of all repurchased securities (whether on GEM or otherwise) is automatically cancelled and the relative certificates must be cancelled and destroyed as soon as reasonably practicable. Under Cayman Islands law, a company's repurchased shares shall be treated as cancelled and the amount of the company's issued share capital shall be reduced by the aggregate nominal value of the repurchased shares accordingly although the authorised share capital of the company will not be reduced.

*(v) Suspension of repurchase*

Any securities repurchase programme is required to be suspended after a price-sensitive development has occurred or has been the subject of directors' decision until the price-sensitive information is made publicly available. In particular, during the period of one month immediately preceding either the preliminary announcement of a company's annual results or the publication of the company's half-year report or quarterly report, a company may not purchase its securities on GEM unless the circumstances are exceptional. In addition, the Stock Exchange may prohibit repurchases of securities on GEM if a company has breached the GEM Listing Rules.

*(vi) Reporting requirements*

Repurchases of securities on GEM or otherwise must be reported to the Stock Exchange not later than 9:30 a.m. (Hong Kong time) on the following business day. In addition, a company's annual report and accounts are required to include a monthly breakdown of securities repurchases made during the financial year under review, showing the number of securities repurchased each month (whether on GEM or otherwise), the purchase price per share or the highest and lowest price per share or the highest and lowest prices paid for all such repurchases and the total prices paid. The directors' report is also required to contain reference to the purchases made during the year and the directors' reasons for making such purchases. The company shall make arrangements with its broker who effects the purchase to provide the company in a timely fashion the necessary information in relation to the purchase made on behalf of the company to enable the company to report to the Stock Exchange.

*(vii) Connected parties*

Under the GEM Listing Rules, a company shall not knowingly purchase shares from a connected person (as defined under the GEM Listing Rules) and a connected person shall not knowingly sell his shares to the company. As at the Latest Practicable Date and to the best of the knowledge of the Directors, having made all reasonable enquires, none of the Directors or their associates (as defined under the GEM Listing Rules) has a present intention to sell Shares to the Company.

**(b) Exercise of the Buyback Mandate**

Exercise in full of the Buyback Mandate, on the basis of 2,000,000,000 Shares in issue immediately after listing of the Shares, could accordingly result in up to 200,000,000 Shares being repurchased by the Company during the period from the passing of the resolution granting the Buyback Mandate up to (i) the conclusion of the next annual general meeting of the Company; (ii) the expiration of the period within which the next annual general meeting of the Company is required by the Articles or the Companies Law or any other applicable laws of the Cayman Islands to be held; or (iii) the revocation, variation or renewal of the repurchase mandate by ordinary resolution of the shareholders of the Company in general meeting, whichever occurs first.

**(c) Reasons for repurchases**

Repurchases of Shares will only be made when the Directors believe that such a repurchase will benefit the Company and its members. Such repurchases may, depending on market conditions and funding arrangements at the time, lead to an enhancement of the net asset value of the Company and/or its earnings per Share.

**(d) Funding of repurchases**

In repurchasing Shares, the Company may only apply funds legally available for such purpose in accordance with its memorandum of association and the Articles and the applicable laws and regulations of the Cayman Islands.

**(e) General**

There might be a material adverse impact on the working capital or gearing position of the Company (as compared with the position disclosed in this prospectus) in the event that the Buyback Mandate is exercised in full. However, the Directors do not propose to exercise the Buyback Mandate to such extent as would, in the circumstances, have a material adverse effect on the working capital requirements of the Company or on its gearing levels which in the opinion of the Directors are from time to time appropriate for the Company.

The Directors have undertaken to the Stock Exchange that, so far as the same may be applicable, they will exercise the Buyback Mandate in accordance with the GEM Listing Rules, the memorandum of association and Articles and the applicable laws of the Cayman Islands. No connected person (as defined in the GEM Listing Rules) of the Company has notified the Company that he has a present intention to sell any Shares to the Company or has undertaken not to do so.

If as a result of a repurchase of Shares, a shareholder's proportionate interest in the voting rights of the Company increases, such increase will be treated as an acquisition for the purpose of the Code on Takeovers and Mergers of Hong Kong (the "Code"). As a result, a shareholder, or a group of shareholders acting in concert (as defined in the Code), depending on the level of increase in the shareholder's interests, could obtain or consolidate control of the Company and become(s) obliged to make a mandatory offer in accordance with Rule 26 of the Code. Save as aforesaid, the Directors are not aware of any other consequence under the Code as a result of a repurchase of Shares made immediately after the listing of the Shares.



## FURTHER INFORMATION ABOUT THE BUSINESS OF THE GROUP

## Summary of material contracts

The following contracts (not being contracts in the ordinary course of business) have been entered into by members of the Group within the two years preceding the date of this prospectus and are or may be material:

- (a) a share transfer contract (in Chinese) 《股權轉讓協議》 dated 28th March, 2001 (together with the share transfer supplemental contract (in Chinese) 《股權轉讓補充協議》 dated 28th March, 2001) entered into between Mr. Jiang Qing (as transferor) and Fujian Wanyou Enterprises Group Limited (福建萬友企業集團有限公司) (as transferee) pursuant to which Fujian Wanyou Enterprises Group Limited (福建萬友企業集團有限公司) acquired 21.36% equity interest in Wanyou Engineering from Mr. Jiang Qing at a consideration of RMB18,000,000;
- (b) a share transfer contract (in Chinese) 《股權轉讓協議》 dated 28th March, 2001 entered into between Mr. Jiang Qing (as transferor) and Ms. Liu Mei Jin (as transferee) pursuant to which Ms. Liu Mei Jin acquired 1% equity interest in Wanyou Engineering from Mr. Jiang Qing at a consideration of RMB70,600;
- (c) a share transfer contract (in Chinese) 《股權轉讓合同》 dated 18th November, 2001 entered into by Mr. Jiang Xiong and Mr. Jiang Qing (as transferors) and Wang Sing (as transferee) pursuant to which the transferors agreed to transfer their respective equity interests of 97% and 3% in Fujian Wanyou Enterprises Group Limited (福建萬友企業集團有限公司) (representing the entire interests in the registered capital of Fujian Wanyou Enterprises Group Limited (福建萬友企業集團有限公司)) to Wang Sing at the respective consideration of HK\$38,800,000 and HK\$1,200,000;
- (d) an assignment (in Chinese) 《轉讓契約》 dated 20th December, 2001 entered into by Wang Sing, Mr. Jiang Xiong and Fujian Wanyou, whereby Mr. Jiang Xiong assigned to Wang Sing the amount due to Mr. Jiang Xiong from Fujian Wanyou as referred to the paragraph headed “Corporate reorganisation” in this appendix;
- (e) a share subscription agreement in respect of shares in Wang Sing dated 27th February, 2002 entered into by Wang Sing, Cantus and Mr. Jiang Xiong, whereby Cantus agreed to, among others, subscribe for 1,000 shares of US\$1.00 each in Wang Sing at a consideration of approximately HK\$40,000,000;
- (f) a subscription agreement relating to shares in the capital of Wang Sing dated 27th February, 2002 entered into by Wang Sing, YMW and Mr. Jiang Xiong, whereby YMW agreed to, among others, subscribe for 219 shares in Wang Sing at a consideration of approximately HK\$8,745,900;
- (g) a subscription agreement relating to shares in the capital of Wang Sing dated 27th February 2002 entered into by Wang Sing, Morita and Mr. Jiang Xiong, whereby Morita agreed to, among others, subscribe for 146 Shares in Wang Sing at a consideration of approximately HK\$5,830,600;

- (h) an agreement dated 20th September, 2002, entered into by the Company, Mr. Jiang Xiong, Cantus, YMW and Morita relating to the sale and purchase of shares in Wang Sing as referred to in the paragraph headed “Corporate reorganisation” in this appendix;
- (i) the Underwriting Agreement;
- (j) a deed of indemnity dated 20th September, 2002 executed by Mr. Jiang Xiong, Mr. Jiang Qing and Mr. Chen Shu Quan in favour of the Company (for itself and as trustee for each of its subsidiaries) containing the indemnities in respect of taxation and other matters referred to in the paragraph headed “Estate duty, tax and other indemnities” in this appendix; and
- (k) a sponsor agreement dated 20th September, 2002, entered into between the Company and the Sponsor whereby the Company has appointed the Sponsor to act as its sponsor for the purpose of the GEM Listing Rules.

### Information about PRC enterprises

The Company has interests in two PRC enterprises, namely Fujian Wanyou and Wanyou Engineering, the particulars of which are as follows:

#### 1. *Fujian Wanyou*

Date of establishment:	20th December, 1993
Nature:	Wholly foreign-owned enterprise
Registered capital:	HK\$10,500,000 fully paid up
Shareholder:	Wang Sing
Attributable interest of the Company:	100 per cent.
Scope of business:	Research, development, production of fire prevention equipment (fire-fighting emergency light, photoelectric – resistant fire prevention ballast, automatic broadcast system, interactive gear control system, fire detector, fire alarm etc.), maintenance and clearing services for the fire prevention equipment.*

#### 2. *WanxjŌ Engineering*

Date of establishment:	23rd December, 1996
Nature:	limited liability company
Registered capital:	RMB7,063,600 fully paid up
Shareholders:	Fujian Wanyou as to 99% Liu Mei Jin as to 1%
Attributable interest of the Company:	99 per cent.
Scope of business:	Design, construction, testing and installation of fire-fighting projects, design and construction of outdoor and indoor fit up and decoration; building materials; indoor decoration materials; wholesale of fire-fighting equipments and act as sales and purchasing agent.*



\* English translation only

**Intellectual property**

As at the Latest Practicable Date, the Group has applied for the trademark registration of the following trademark:

Trademark	Class	Items covered	Application number	Application date	Place of application
WANYOU 萬友 	9	Fire prevention and fire fighting systems and equipment, electrical apparatus, namely, fire extinguishers; fire extinguishing systems comprising fire extinguishers and fire sprinklers; anti-theft warning devices, namely burglar alarms; smoke detectors; smoke alarms; fire and burglar alarm systems comprising switches, audio speakers, and monitors; sound amplifiers and audio speakers for fire and burglar alarms; electric door bells; emergency lighting systems comprising emergency warning lights; and electric lighting switches and starters	2002 10751	13th July, 2002	Hong Kong

As at the Latest Practicable Date, the Group owned, or had registered the following trademarks:

Trademark	Class	Items covered	Country of registration	Registration number	Renewal date
WANYOU 萬友 	9	fire-extinguishing apparatus *	PRC	1358784	27th January, 2010
萬友 	9	fire-extinguishing apparatus *	PRC	1135487	13th December, 2007
萬開 	11	apparatus for lighting, heating, steam, gathering, cooking, refrigerating, drying, ventilating, water supply and sanitary purposes *	PRC	800454	20th December, 2005

As at the Latest Practicable Date, the Group owned, or had registered the following patents:

Patent Description	Country of Registration	Patent Number	Application Date	Registration/Announcement Date
Second Class Fluorescent Beacon light* 《發光二極管 標誌燈》	PRC	ZL 01 2 37462.8	19th April, 2001	10th April, 2002
Moving frame* 《活動架》	PRC	ZL 00 2 40892.9	3rd November, 2000	19th September, 2001
Auto-switching fire-fighting fluorescent emergency lamp for AC and DC with regular auto-checking facilities* 《一種定時自檢式 交直流兩用自動 轉換螢光燈》	PRC	ZL 96 1 01654.X International patent number: F21S 2/00	17th February, 1996	16th September, 2000
Connection utility 《鉸接裝置》	PRC	ZL 99 2 02155.3	15th January, 1999	3rd March, 2000
Automatic fire-fighting emergency light* 《消防自動應急燈》	PRC	ZL 98 2 27055.0	11th June, 1998	12th June, 1999
Fire-fighting emergency lighting with situation indicators* 《一種可顯示 所處狀態的 消防應急燈》	PRC	ZL 98 2 27054.2	11th June, 1998	12th June, 1999
Beacon light (B)* 《指示標誌燈(B)》	PRC	ZL 98 3 13631.9	4th June, 1998	8th April, 1999
Beacon light for evacuation (A)* 《疏散指示 標誌燈(A)》	PRC	ZL 98 3 13629.7	4th June, 1998	20th February, 1999

Patent Description	Country of Registration	Patent Number	Application Date	Registration/Announcement Date
Guiding light (A)* 《誘導燈(A)》	PRC	ZL 97 3 27180.9	2nd December, 1997	26th September, 1998
Automatic fire-fighting emergency light (A)* 《消防自動應急燈(A)》	PRC	ZL 97 3 17265.7	24th September 1997	19th September, 1998
Indicator light* 《指示燈》	PRC	ZL 97 3 27181.7	2nd December, 1997	29th August, 1998
Automatic fire-fighting emergency light (C)* 《消防自動應急燈(C)》	PRC	ZL 97 3 17267.3	24th September, 1997	22nd August, 1998
Photoelectron-resistant fire prevention ballast* 《防火電子鎮流器》	PRC	ZL 97 3 17287.8	2nd October, 1997	15th August, 1998
Fire prevention tripping ballast* 《全脫扣式防火鎮流器》	PRC	ZL 96 2 45920.8	25th October, 1996	10th January, 1998
Auto-switching fire-fighting fluorescent emergency lamp for AC and DC with regular auto-checking facilities* 《一種定時自檢式交直流兩用自動轉換螢光燈》	PRC	ZL 95 2 05458.2	8th March, 1995	8th February, 1997

Patent Description	Country of Registration	Patent Number	Application Date	Registration/Announcement Date
Auto-switching fire-fighting fluorescent emergency lamp for AC and DC* 《一種交直流兩用自動轉換螢光燈》	PRC	ZL 94 2 03619.0	5th February, 1994	14th September, 1994

\* English translation

As at the Latest Practicable Date, the Group has registered the following domain name:

Domain Names	Date of registration
www.wanyoufire.com	4th February, 2002

#### FURTHER INFORMATION ABOUT DIRECTORS, SENIOR MANAGEMENT AND STAFF

##### Directors

Each of the executive Directors is, to such extent as relevant to him, interested in the material contracts set out in the paragraph headed “Summary of material contracts” under the section headed “Further information about the business of the Group” in this appendix.

Save as disclosed below, immediately following completion of the Placing, none of the Directors and chief executive has any beneficial interests in the share capital of the Company or any of its associated corporations (within the meaning of the SDI Ordinance) which will have to be notified to the Company and the Stock Exchange pursuant to section 28 of the SDI Ordinance (including interests which they are taken or deemed to have under section 31 of, or Part 1 of the Schedule to, the SDI Ordinance) once the Shares are listed, or which will be required, pursuant to section 29 of the SDI Ordinance, to be entered in the register referred to therein once the Shares are listed, or pursuant to Rules 5.40 to 5.59 of the GEM Listing Rules relating to securities transactions by Directors to be notified to the Company and the Stock Exchange once the Shares are listed will be as follows:

Name of Director	Personal interest	Number of Shares			Other interests	Total
		Family interest	Corporate interest			
Mr. Jiang Xiong	1,281,600,000	–	–	–	1,281,600,000	

**Particulars of service agreements**

Each of the executive Directors has entered into a service agreement with the Company. Particulars of these agreements, except as indicated, are in all material respects identical and are set out below:

Each of the executive Directors has entered into a service agreement with the Company for a term of three years with a fixed term of one year commencing from the Listing Date. Each of the executive Directors is entitled to the respective basic salaries set out below which is payable in arrears at the end of each calendar month on a 13 month basis, subject to an annual increment after each completed year of service at a rate to be determined at the sole and absolute discretion of the board of Directors, provided that such increase shall not exceed 10 per cent. of the then current annual remuneration of the relevant Director. In addition, the executive Directors are also entitled to a discretionary bonus as the board of Directors may in its absolute discretion determine having regard to the performance of the executive Director and the operating results of the Group which, in respect of any financial year of the Company, shall not be more than 10 per cent. of the audited consolidated net profit after taxation and minority interests but before extraordinary and exceptional items of the Group for that financial year, which amount shall be paid within one calendar month after the announcement of the audited final results of the Group for that financial year. The discretionary bonus shall only be payable when the audited consolidated net profit after taxation and minority interests but before extraordinary and exceptional items of the Group and before payment of the total discretionary bonuses payable to all the executive Directors shall exceed HK\$8 million. The executive Director shall abstain from voting and shall not be counted in the quorum in respect of the resolution of the board of Directors regarding any payment of discretionary bonus or increase of remuneration or discretionary bonus payable to him. The current basic annual salaries of the executive Directors are as follows:

<b>Name</b>	<b>Amount</b> <i>(HK\$)</i>
Mr. Jiang Xiong	390,000
Mr. Jiang Qing	390,000
Mr. Chen Shu Quan	390,000

Save as disclosed, none of the Directors has entered or has proposed to enter into any service agreements with the Company or any members of the Group (other than contracts expiring or determinable by the employer within one year without payment of compensation).

**Directors' remuneration**

- (a) An aggregate of approximately RMB118,000 was paid to the Directors as remuneration for the year ended 31st December, 2001. Further information in respect of the Directors' remuneration is set out in Appendix I to this prospectus.
- (b) It is expected that an aggregate sum of approximately HK\$700,000 will be paid to the Directors as remuneration by the Group in respect of the year ending 31st December, 2002 pursuant to the present arrangement including management bonus.
- (c) No performance bonus was paid to the Directors for the two years ended 31st December, 2001.

- (d) None of the Directors or any past directors of any member of the Group has been paid any sum of money for each of the two years ended 31st December, 2001 and the seven months ended 31st July, 2002 (i) as an inducement to join or upon joining the Company or (ii) for loss of office as a director of any member of the Group or of any other office in connection with the management of the affairs of any member of the Group.
- (e) There has been no arrangement under which a Director has waived or agreed to waive any emoluments for each of the two years ended 31st December, 2001 and the seven months ended 31st July, 2002.

**Agency fees or commissions received**

The Underwriters will receive a commission of 3.5 per cent. of the Issue Price of all the Shares under the Placing underwritten by them and the Shares under the Over-allotment Option, out of which they will pay any sub-underwriting commission, if any. The Sponsor will also receive a documentation fee and be reimbursed for its expenses. Such commission, documentation fee and expenses, together with the Stock Exchange listing fees, legal and other professional fees, and printing and other expenses relating to the Placing, which are estimated to amount in aggregate to approximately HK\$23 million, will be payable by the Company as to 80% and by Mr. Jiang Xiong as to 20% and if the Over-allotment Option is exercised in full, the Group will bear 82.61% while Mr. Jiang Xiong will bear 17.39% of such commission, fees and expenses, respectively.

**Substantial shareholders**

As far as the Directors are aware, after the Placing, no person (other than Mr. Jiang Xiong) as disclosed in the sub-paragraph headed “Directors” under the paragraph headed “Further information about Directors, senior management and staff” in this appendix) will be directly or indirectly interested in 10 per cent. or more of the voting power at any general meeting of the Company.

**Related party transactions**

Within two years immediately preceding the date of this prospectus, the Group entered into the related party transactions as mentioned in note 33 to the accountants’ report set out in Appendix I to this prospectus and the paragraph headed “Summary of material contracts” under the section headed “Further information about the business of the Group” in this appendix.

**Disclaimers**

Save as disclosed herein:

- (a) none of the Directors or chief executive of the Company has for the purposes of section 28 of the SDI Ordinance, nor is any of them taken to or deemed to have under section 31 of, or Part 1 of the Schedule to, the SDI Ordinance, any interests in the securities of the Company or any of its associated corporations (within the meaning of the SDI Ordinance) or any interests which will have to be entered in the register to be kept by the Company pursuant to section 29 of the SDI Ordinance or Rules 5.40 to 5.59 of the GEM Listing Rules relating to securities transactions by Directors to be notified to the Company and the Stock Exchange once such securities are listed on the Stock Exchange;



- (b) none of the Directors nor any of the persons whose names are listed in the subparagraph headed “Consent of experts” under the paragraph headed “Other information” in this appendix is interested in the promotion of the Company or in any assets which have within the two years immediately preceding the issue of this prospectus been acquired or disposed of by or leased to any member of the Group, or are proposed to be acquired or disposed of by or leased to any member of the Group;
- (c) none of the Directors nor any of the persons whose names are listed in the paragraph headed “Consents of experts” under the paragraph headed “Other Information” in this appendix is materially interested in any contract or arrangement subsisting at the date of this prospectus which is significant in relation to the business of the Group;
- (d) none of the persons whose names are listed in the paragraph headed “Consents of experts” under the paragraph headed “Other information” in this appendix has any shareholding in any member of the Group or the right (whether legally enforceable or not) to subscribe for or to nominate persons to subscribe for securities in any member of the Group;
- (e) none of the Directors has entered or has proposed to enter into any service agreements with the Company or any members of the Group (other than contracts expiring or determinable by the employer within one year without payment of compensation other than statutory compensation);
- (f) no cash, securities or other benefit has been paid, allotted or given within the two years preceding the date of this prospectus to any promoter of the Company nor is any such cash, securities or benefit intended to be paid, allotted or given on the basis of the Placing or related transactions as mentioned in this prospectus; and
- (g) none of the Directors, their respective associates (as defined in the GEM Listing Rules) or shareholders of the Company who are interested in 5 per cent. or more of the issued share capital of the Company so far as is known to the Directors have any interests in the five largest customers or suppliers of the Group.

### Share Option Scheme

The following is a summary of the principal terms of the Share Option Scheme conditionally approved by a written resolution of the sole shareholder of the Company passed on 20th September, 2002:

#### *Purpose of the Share Option Scheme*

The purpose of the Share Option Scheme is to advance the interests of the Company and its shareholders by providing to Eligible Persons (as defined below) a performance incentive for continued and improved service with the Company and its subsidiaries and by enhancing such persons' contribution to increase profits by encouraging capital accumulation and share ownership.

#### *(a) Who may join*

A duly authorised committee of the board of directors of the Company, including all the independent non-executive directors of the Company for the time being (and also the independent non-executive directors of any holding company of the Company which is also

listed on the Main Board or on GEM) (“Committee”) may, at its discretion, invite any full-time employee of the Company or any of its subsidiaries including any executive and non-executive directors of the Company or any of its subsidiaries (“Eligible Persons”) to take up options to subscribe for Shares.

(b) *Grant of option*

- (i) On and subject to the terms of the Share Option Scheme, the Committee shall be entitled from time to time within 10 years from 20th September, 2002 to offer to any Eligible Person as the Committee may in its discretion select, and subject to such terms and conditions as the Committee may think fit, options to subscribe for such number of Shares as the Committee may determine at the subscription price calculated in accordance with paragraph (d) below.
- (ii) Any grant of option must not be made after a price sensitive event has occurred or a price sensitive matter has been the subject of a decision, until such price sensitive information has been announced in accordance with the requirements of the GEM Listing Rules. In particular, no option shall be granted during the period of one month immediately preceding the earlier of (1) the date of the board meeting of the Company (as such date is first notified to the Stock Exchange pursuant to Rule 17.48 of the GEM Listing Rules) for the approval of the Company’s quarterly, interim or annual results; and (2) the deadline for the Company to publish its quarterly, interim or annual results announcement under Rule 18.49 or Rule 18.53 of the GEM Listing Rules.

(c) *Payment on acceptance of option offer*

Upon acceptance of the option, the Eligible Person shall pay HK\$1.00 to the Company by way of consideration for the grant. The option will be offered to the Eligible Person for acceptance for a period of 21 days from the date on which the option is offered to the Eligible Person.

(d) *Price of Shares*

The subscription price for the Shares on the exercise of options granted under the Share Option Scheme shall be the fair market value of the Shares, as determined by the Committee, which should be calculated by reference to and, in any event, shall be at least the higher of (i) the closing price of the Shares on GEM as stated in the Stock Exchange’s daily quotations sheet on the date upon which the relevant option is deemed to be granted and accepted (“Commencement Date”), which must be a business day; (ii) the average closing price of the Shares on GEM as stated in the Stock Exchange’s daily quotations sheets for the five business days immediately preceding the Commencement Date of the relevant option; and (iii) the nominal value of a Share.

For the avoidance of doubt, in the event that the Company has been listed on the GEM for less than 5 business days, the offer price per Share for the Company’s initial public offering shall be used as the closing price for any business day falling within the period before listing.

(e) *Maximum number of Shares available for subscription*

- (i) The overall limit on the number of Shares which may be issued upon exercise of all outstanding options granted and yet to be exercised under the Share Option Scheme and any other schemes must not exceed 30% of the Shares in issue from time to time (“Scheme Limit”).
- (ii) The total number of Shares available for issue under options which may be granted under the Share Option Scheme and any other schemes must not in aggregate exceed 10% of the Shares in issue as at the date of approval of the Share Option Scheme (“Scheme Mandate Limit”), unless Shareholders’ approval has been obtained pursuant to sub-paragraph (iii) below. On the basis of 2,000,000,000 Shares in issue immediately after listing of the Shares, the Scheme Mandate limit initially will be 200,000,000 Shares available for issue under options which may be granted under the Share Option Scheme. Options lapsed in accordance with the terms of the Share Option Scheme shall not be counted for the purpose of calculating the Scheme Mandate Limit.
- (iii) The Scheme Mandate Limit may be renewed at any time subject to Shareholders’ approval in general meeting. The Scheme Mandate Limit as “refreshed” must not exceed 10% of the securities in issue at the date of the approval of the Scheme Mandate Limit. Options previously granted under the Share Option Scheme and any other schemes of the Company (including those outstanding, cancelled, lapsed in accordance with the Share Option Scheme or exercised options) will not be counted for the purpose of calculating the Scheme Mandate Limit as “refreshed”. A circular for the purpose of seeking Shareholders’ approval on the renewal of the Scheme Mandate Limit containing information required under the GEM Listing Rules must be sent to the Shareholders.
- (iv) The total number of Shares issued and to be issued upon exercise of the options granted to each Eligible Person (including both exercised and outstanding options) in any 12-month period up to the date of the grant to such Eligible Person shall not exceed 1% of the Shares in issue (the “1% Limit”). Any further grant of options in excess of this 1% Limit must be subject to Shareholders’ approval with that Eligible Person and his associates (as defined in the GEM Listing Rules) abstaining from voting and the issue of a circular. The circular must disclose the identity of such grantee, the number and the terms of the options granted and to be granted. The number and terms of the options to be granted to such Eligible Person must be fixed before the Shareholders’ approval and the date of the board meeting of the Company for proposing such further grant should be taken as the date of grant for the purpose of calculating the subscription price.
- (v) The Company may also seek separate Shareholders’ approval for granting options beyond the Scheme Mandate Limit to Eligible Persons specifically identified by the Company before such approval is sought and subject to Shareholders’ approval and the issue of a circular to all the Shareholders. The circular must contain a generic description of the identified grantee, the number and terms of the options to be granted, the purpose of granting options to the identified grantee, an explanation as to how the terms of such options serve the intended purpose and such other information as the Shareholders consider applicable.

(f) *Time of exercise of option*

Subject to paragraph (l) below, an option may be exercised in whole or in part at any time during a period from the Commencement Date and ending on such date as the Committee may notify to each grantee but in any event not exceeding 10 years from the Commencement Date (“Option Period”) by the grantee (in the case of his or her death, his or her legal personal representatives) giving notice in writing to the Company stating that the option is thereby exercised and the number of Shares in respect of which it is exercised. The exercise of options by a grantee is not tied to any performance target requirements.

(g) *Rights are personal to grantee*

Except for a transfer to an offeror pursuant to an offer made in accordance with the Code on Takeovers and Mergers of Hong Kong, an option shall be personal to the grantee and shall not be assignable and no grantee shall in any way sell, assign, transfer, charge, mortgage, encumber or create any interest in favour of any third party over or in relation to any option.

(h) *Rights on death*

If the grantee of an option dies before exercising the option in full, his or her personal representatives may exercise the option in full (to the extent not already exercised) within a period of 12 months from the date of death, failing which the option will lapse.

(i) *Changes in capital structure*

Subject to paragraph (e)(i) and (ii), if there is any alteration in the capital structure of the Company while any option remains exercisable, whether by way of capitalisation of profits or reserves, rights issue, consolidation, subdivision or reduction of the share capital of the Company (other than an issue of Shares as consideration in respect of a transaction to which the Company is a party) or otherwise, such corresponding alterations (if any) shall be made in:

- (i) the number of Shares (without fractional entitlements) subject to the option so far as unexercised; and/or
- (ii) the subscription price.

Except alterations made on a capitalisation issue, any alteration to the number of Shares subject to the option, the subscription price and/or the method of exercise of the option shall be conditional on the auditors of the Company confirming in writing to the board of directors of the Company or the Committee that the alteration made is on the basis that the proportion of the issued share capital of the Company to which a grantee is entitled after such alteration shall remain the same as that to which he or she was entitled before such alteration. No such alteration shall be made to the effect of which would be to enable any Share to be issued at less than its nominal value or which would result in the aggregate amount payable on the exercise of any option in full being increased. The capacity of the auditors is that of experts and not of arbitrators and their certification shall be final and binding on the Company and the grantees in the absence of manifest error. The costs of the auditors in so certifying shall be borne by the Company.

(j) *Rights on take-over*

Subject to paragraph (l) if an offer has been made to acquire all or part of the issued Shares, or all or part of the issued Shares other than those held by the offeror and any persons acting in concert with the offeror, and the Company becomes aware that the right to cast more than 50 per cent. of the votes which may ordinarily be cast on a poll at a general meeting of the Company in respect of issued Shares has or will become vested in the offeror and/or any such persons, the Company shall give written notice to all grantees of options of such vesting as soon as reasonably practicable after becoming so aware. Each grantee of options may by notice in writing to the Company within 21 days of the date of such notice exercise his or her outstanding option to its full extent or to the extent specified in such notice. If a grantee fails to notify the Company, his or her outstanding option will lapse. For the purposes of this paragraph, “acting in concert” shall mean persons who, pursuant to an agreement or understanding, actively co-operate to obtain a holding, or aggregate holdings, of more than 50 per cent. of the issued Shares.

(k) *Rights on a compromise or arrangement*

- (i) Subject to paragraph (l), in the event of a compromise or scheme of arrangement between the Company and its members or creditors being proposed in connection with the scheme for the reconstruction or amalgamation of the Company, the Company shall give notice thereof to all grantees on the same day as it gives notice of the meeting to its members or creditors summoning the meeting to consider such a compromise or arrangement and the grantees (or his personal representatives) may by notice in writing to the Company accompanied by the remittance for the full amount of the aggregate subscription price for the Shares in respect of which the notice is given (such notice to be received by the Company not later than two business days prior to the proposed meeting) exercise the option (to the extent not already exercised) either to its full extent or to the extent specified in such notice and the Company shall as soon as possible and in any event no later than the business day immediately prior to the date of the proposed meeting, allot and issue such number of Shares to the grantee which falls to be issued on such exercise credited as fully paid and register the grantee as holder thereof. Upon the compromise or arrangement becoming effective, all outstanding options shall lapse except insofar as exercised.
- (ii) Subject to paragraph (l), in the event of a notice being given by the Company to its shareholders to convene a general meeting for the purpose of considering, and if thought fit, approving a resolution to voluntarily wind-up the Company when the Company is solvent, the Company shall on the day of such notice to each shareholders or as soon as practicable, give notice thereof to all grantees of options (together with a notice of the existence of this provision). Thereupon each grantee (or where permitted his legal personal representatives) shall be entitled to exercise all or any of his outstanding options at any time not later than two business days prior to the proposed general meeting of the Company by giving notice in writing to the Company, accompanied by a remittance for the full amount of the aggregate subscription price for the Shares in respect of which the notice is given, whereupon the Company shall as soon as possible and, in any event, no later than the business day immediately prior to the date of the proposed general meeting referred to above, allot and issue the relevant Shares to the relevant grantee credited as fully paid.

- (iii) Subject to paragraph (1), in the event of a reorganisation or proposed reorganisation of the Company, at its option, may do either of the following:
- (1) the Company may irrevocably commute for or into any other securities or other property or cash any option that is still capable of being exercised, upon giving to the relevant grantee to whom such option has been granted at least 21 days written notice of its intention to commute the option, and during such period of notice, the option, to the extent that it has not been exercised, may be exercised by the relevant grantee by notice in writing to the Company to its full extent or to the extent specified in such notice and on the expiry of such period of notice, the unexercised portion of the option shall lapse and be cancelled, or
  - (2) the Company or any company which is or would be the successor to the Company or which may issue securities in exchange for Shares upon the reorganisation becoming effective, may offer any grantee the opportunity to obtain a new or replacement option over any securities into which the Shares are changed or are convertible or exchangeable, on a basis proportionate to the number of Shares under option. In such event, the grantees shall, if the grantees accept such offer, be deemed to have released such grantee's option over Shares and such option shall be deemed to have lapsed automatically upon acceptance of the aforesaid offer by the grantee.

Reorganisation means any (aa) compromise or arrangement, or (bb) offer for Shares which if successful would entitle the offeror to acquire all of the Shares or all of one or more particular class(es) of Shares to which the offer relates. Sub-paragraph (iii) (1) and (2) above are intended to be permissive and may be utilised independently or successively in combination or otherwise, and nothing therein contained shall be construed as limiting, or affecting the ability of the Company to deal with options in any other manner.

*(1) Lapse of option*

An option shall lapse forthwith (to the extent not already exercised) on the earliest of the following events:

- (i) the relevant Option Period of the option having expired;
- (ii) the first anniversary of the death of the relevant grantee;
- (iii) the date on which the Group terminates the employment of the relevant grantee or removes the grantee from his or her office on the ground that such grantee commits an act of bankruptcy or has become insolvent or has made any arrangements or composition with his creditors generally, or has been convicted of any criminal offence involving his or her integrity or honesty. A resolution of the board of directors of the Company to the effect that the employment of such a person has or has not been terminated on one or more of the grounds specified in this sub-paragraph shall be conclusive and binding on the grantee;

- (iv) the expiry of a period of three months from the date of the grantee ceasing to be an Eligible Person by reason of:
  - (1) his or her retirement on or after attaining normal retirement age or, with the express consent of the board of directors of the Company in writing for the purpose of this paragraph, at a younger age;
  - (2) ill health or disability recognised as such expressly by the board of directors of the Company in writing for the purpose of this paragraph;
  - (3) the company by which he or she is employed and/or of which he or she is a director (if not the Company) ceasing to be a subsidiary of the Company;
  - (4) expiry of his or her employment contract or the vacation of his or her office with the Company or a subsidiary of the Company and such contract is not immediately extended or renewed; or
  - (5) at the discretion of the Committee, any reason other than death or the reasons described in this paragraph l(iii) or l(iv)(1) to (4).
- (v) the expiry of any period referred to in paragraphs (j) and (k) above, provided that:
  - (1) (in the case of paragraph (j)) the offeror may exercise any options tendered in acceptance of its offer within one (1) month after the date on which the offer becomes or is declared unconditional; and
  - (2) (in the case of paragraph (k)(i)) all options granted shall lapse upon the proposed compromise or arrangement becoming effective; or
- (vi) the date the relevant grantee commits any breach of the provisions of paragraph (g).

*(m) Ranking of Shares and rights of optionholders*

The Shares to be allotted upon the exercise of an option will be subject to the Articles for the time being in force and will rank *pari passu* with the fully paid Shares in issue on the date of exercise of the option including in respect of those rights arising on a liquidation of the Company.

A Share allotted upon the exercise of an option shall not carry voting rights until the registration on the register of shareholders of the grantee (or any other person) as the holder thereof. If under the terms of a resolution passed or an announcement made by the Company prior to the date of exercise of an option, a dividend is to be or is proposed to be paid to holders of Shares by reference to a record date prior to such date of exercise, the Shares to be issued upon such exercise will not rank for such dividend.

(n) *Cancellation of options granted*

Any cancellation of options granted but not exercised must be approved by the shareholders of the Company (and also by shareholders of any holding company which is listed on Main Board or on GEM) in general meeting, with grantees and their associates (as defined in the GEM Listing Rules) abstaining from voting. Any vote taken at the meeting to approve such cancellation must be taken by poll.

(o) *Period of Share Option Scheme*

The Share Option Scheme will remain valid for a period of 10 years commencing on 20th September, 2002 after which period no further options will be granted but the provisions of the Share Option Scheme shall in all other respects remain in full force and effect and options which are granted during the life of the Share Option Scheme may continue to be exercisable in accordance with their terms of issue.

(p) *Alteration to and termination of Share Option Scheme*

The Share Option Scheme may be altered in any respect by resolution of the board of directors of the Company or the Committee except that the provisions of the Share Option Scheme relating to Rule 23.03 of the GEM Listing Rules, shall not be altered to the advantage of the Eligible Persons, grantees or prospective grantees provided that prior sanction of a resolution of the Company in general meeting has been obtained, with Eligible Persons, the grantees and their respective associates (as defined in the GEM Listing Rules) abstaining from voting. No alteration shall operate to affect adversely the terms of issue of any option granted or agreed to be granted prior to such alteration except with the consent or sanction of such number of grantees of options as shall together hold options in respect of not less than three-fourths in nominal value of all Shares then subject to options granted under the Share Option Scheme.

Any alteration to the terms and conditions of Share Option Scheme, which are of a material nature, must be approved by the shareholders of the Company, except where such alterations take effect automatically under the existing terms of the Share Option Scheme.

The Company may at any time by ordinary resolution in general meeting terminate the operation of the Share Option Scheme before the end of its life and in such event no further options will be offered but the provisions of the Share Option Scheme shall, subject to the terms therein, remain in all other respects in full force and effect of any options granted prior thereto but not yet exercised at the time of termination. Options complying with the provisions of Chapter 23 of the GEM Listing Rules which are granted during the life of the Share Option Scheme and remain unexpired immediately prior to the termination of the operation of the Share Option Scheme shall continue to be exercisable in accordance with their terms of issue within one month after the termination of the operation of the Share Option Scheme.

(q) *Grant of Options to connected persons, Directors or any of their associates*

Where options are proposed to be granted to a connected person or his associates (as defined in the GEM Listing Rules), the proposed grant must be approved by all independent non-executive directors of the Company (except independent non-executive director who is the grantee of the relevant options).



If a grant of options to a substantial shareholder or an independent non-executive director or their respective associates (as defined in the GEM Listing Rules) will result in the total number of the Shares issued and to be issued upon exercise of the options granted and to be granted (including both exercised, cancelled and outstanding options) in any 12-month period up to and including the date of the grant to such person exceeding the higher of 0.1% of the Shares in issue and an aggregate value, based on the closing price of the shares at the date of each grant, in excess of HK\$5 million, then the proposed grant of options must be subject to approval of the shareholders of the Company in general meeting taken on a poll. All connected persons must abstain from voting, except that any connected person may vote against the resolution provided that his intention to do so has been stated in the relevant circular to the shareholders of the Company.

The circular must contain the following:

- (i) details of the number and terms of the options to be granted to each grantee, which must be fixed before obtaining the approval of the shareholders of the Company and the date of board meeting shareholders of the Company for proposing such further grant should be taken as the date of grant for the purpose of calculating the subscription price;
- (ii) a recommendation from the independent non-executive directors (excluding any independent non-executive director who is a grantee) to independent shareholders of the Company as to voting; and
- (iii) information required under Rules 23.02(2)(c) and (d) of the GEM Listing Rules and the disclaimer required under Rule 23.02(4) of the GEM Listing Rules.

Shareholders' approval as described above is required for any change in the terms of options granted to an Eligible Person who is a substantial shareholder, an independent non-executive director or their respective associates (as defined in the GEM Listing Rules).

For the avoidance of doubt, the requirements for granting of options to a director, or chief executive of the Company set out above do not apply where the Eligible Person is only a proposed director or chief executive of the Company.

*(r) Conditions of Share Option Scheme*

The Share Option Scheme is conditional on (i) the GEM Listing Committee of the Stock Exchange granting approval of the listing of and permission to deal in the Shares which may be issued pursuant to the exercise of options granted under the Share Option Scheme and (ii) the passing of a written resolution to adopt the Share Option Scheme by the sole shareholder of the Company.

As at the date hereof, no options have been granted or agreed to be granted by the Company under the Share Option Scheme.

Application has been made to the Stock Exchange for the listing of and permission to deal in the Shares which fall to be issued pursuant to the exercise of options granted under the Share Option Scheme.

## OTHER INFORMATION

**Estate duty, tax and other indemnities**

Each of the executive Directors (together, the “Indemnifiers”) have entered into a deed of indemnity (“Deed”) with and in favour of the Company (for itself and as trustee for its subsidiaries) (being material contract (j) as referred to in the paragraph headed “Summary of material contracts” in this appendix) to provide indemnities on a joint and several basis in respect of, among other matters, any liability for Hong Kong estate duty which might be incurred by any member of the Group by reason of any transfer of property (within the meaning of section 35 of the Estate Duty Ordinance, Chapter 111 of the Laws of Hong Kong)) (“Estate Duty Ordinance”) to any member of the Group on or before the date on which the Placing becomes unconditional. The Indemnifiers have also given indemnities to the Group on a joint and several basis in relation to taxation which might be payable by any member of the Group in respect of any income, profits or gains earned, accrued or received on or before the date on which the Placing becomes unconditional. The Indemnifiers shall be under no liability under the Deed in respect of Taxation (as defined therein):

- (a) to the extent that provision, reserve or allowance has been made for such Taxation (as defined therein) in the audited accounts of the Company and its subsidiaries for the period ended 31st July, 2002;
- (b) where such liability has arisen as a result of any act or omission by any member of the Group (whether alone or in conjunction with some other act, omission or transaction whenever occurring) voluntarily effected without the consent of the Indemnifiers otherwise than in the ordinary course of business after 31st July, 2002;
- (c) for which any member of the Group is liable as a result of any transaction entered into by it in the ordinary course of business after 31st July, 2002;
- (d) to the extent that such Claim (as defined therein) arises or is incurred as a result of the imposition of Taxation (as defined therein) as a consequence of any retrospective change in the law or the interpretation or practice by the Inland Revenue Department of Hong Kong or any other relevant authority (whether in Hong Kong, the PRC, the US, or any other part of the world)) coming into force after the date of the Deed or to the extent that such Claim (as defined therein) arises or is increased by an increase in rates of Taxation (as defined therein) after the date of the Deed with retrospective effect;
- (e) to the extent of any provision or reserve made for Taxation (as defined therein) in the audited accounts of the Company as at 31st July, 2002 which is finally established to be an over-provision or any excessive reserve then the Indemnifiers’ liability (if any) in respect of Taxation (as defined therein) shall be reduced by an amount not exceeding such provision or reserve applied pursuant to this sub-paragraph to reduce the Indemnifiers’ liability in respect of such Taxation (as defined therein) shall not be available in respect of any such liability arising thereafter in which event the Indemnifiers shall be obliged to indemnify each member of the Group against any liability, loss or damage arising from such liability;

- (f) to the extent that Taxation (as defined therein) arises as a result of the member of the Group or any of them being in breach of the Deed; and
- (g) imposed on any member of the Group under section 42 of the Estate Duty Ordinance by reason of any member of the Group defaulting in any obligation to give information to the Commissioner under section 42(1) of the Estate Duty Ordinance.

The Company has been advised that no material liability for estate duty is likely to fall on the Company or any of its subsidiaries in the Cayman Islands, US, BVI or PRC, being jurisdictions in which one or more of the companies comprising the Group are incorporated.

The Indemnifiers have also given indemnities to the Group on a joint and several basis against any losses, claims, damages, costs, charges, expenses, liabilities, demands, proceedings or actions which may have been incurred or suffered by any member of the Group (i) resulting from or due to a claim for breach of warranty, manufacturing defect, design defect, merchantability, fitness for purpose, negligence or product liability or any other claim attributable to the products sold or to be sold and/or services provided or to be provided by the Group from time to time before Listing Date; and (ii) in respect of any liability in connection with or arising out of any non-compliance and/or breach of the term of any authorisations, permits or approvals that may be obtained, or required in relation to the properties owned and occupied by the Group in the PRC as at the Latest Practicable Date; and (iii) as a result of, or in connection with, the relocation due to the expiry or termination of the existing tenancy of the Group's production facility located at No. 83 Zhan Jin Xiang, Xian Feng Village, Cang Shan Town, Cang Shan District, Fuzhou City, Fujian Province, the PRC.

### **Litigation**

No member of the Group is engaged in any litigation or arbitration of material importance and no litigation or claim of material importance is known to the Directors to be pending or threatened against any member of the Group.

### **Sponsor**

The Sponsor have made an application on behalf of the Company to the GEM Listing Committee of the Stock Exchange for listing of, and permission to deal in, the Shares in issue and to be issued as mentioned herein.

The Sponsor, will receive normal professional fees in connection with the advisory services to be provided to the Company for a term period covering the remainder of the financial year ending 31st December, 2002 and the two financial years thereafter.

### **Preliminary expenses**

The preliminary expenses of the Company are estimated to be approximately HK\$35,000 and are payable by the Company.

**Particulars of the Vendor**

<b>Name</b>	<b>Description</b>	<b>Address</b>	<b>Number of Sale Shares</b>
Mr. Jiang Xiong	Initial Management Shareholder, individual	Flat 941, 9th Floor, Block D, Metropole Building, 416-430 King's Road, North Point, Hong Kong	100,000,000

**Promoters**

The promoter of the Company is Mr. Jiang Xiong. Save as disclosed herein, within the two years preceding the date of this prospectus, no amount or benefit has been paid or given to the promoter in connection with the Placing or the related transactions described in this prospectus.

**Registration procedures**

The register of members of the Company will be maintained in the Cayman Islands by Bank of Butterfield International (Cayman) Ltd. and a branch register of members of the Company will be maintained in Hong Kong by Computershare Hong Kong Investor Services Limited. Save where the Directors otherwise agree, all transfers and other documents of title to Shares must be lodged for registration with, and registered by, the Company's share registrar in Hong Kong and may not be lodged in the Cayman Islands.

**Qualifications of experts**

The following are the qualifications of the experts who have given opinion or advice which are contained in this prospectus:

<b>Name</b>	<b>Qualification</b>
Core Pacific-Yamaichi Capital Limited	Registered investment adviser and securities dealer
Conyers Dill & Pearman, Cayman	Cayman Islands attorneys-at-law
Greater China Appraisal Limited	Property valuers
Chen & Co.	PRC legal advisers
Deloitte Touche Tohmatsu	Certified public accountants

**Consents of experts**

Each of Core Pacific-Yamaichi Capital Limited, Conyers Dill & Pearman, Cayman, Greater China Appraisal Limited, Chen & Co. and Deloitte Touche Tohmatsu has given and has not withdrawn its written consent to the issue of this prospectus with the inclusion of its report and/or letter and/or valuation certificate and/or the references to its name included herein in the form and context in which they are respectively included.

**Binding effect**

This prospectus shall have the effect, if an application is made in pursuance hereof, of rendering all persons concerned bound by all of the provisions (other than the penal provisions) of sections 44A and 44B of the Companies Ordinance insofar as applicable.

**Miscellaneous**

- (a) Save as disclosed in this prospectus:
- (i) within the two years preceding the date of this prospectus, no share or loan capital of the Company or any of its subsidiaries has been issued or agreed to be issued fully or partly paid either for cash or for a consideration other than cash;
  - (ii) no share or loan capital of the Company or any of its subsidiaries is under option or is agreed conditionally or unconditionally to be put under option;
  - (iii) no founders, management or deferred shares of the Company or any of its subsidiaries have been issued or agreed to be issued; and
  - (iv) within the two years preceding the date of this prospectus, no commissions, discounts, brokerages or other special terms have been granted in connection with the issue or sale of any capital of the Company or any of its subsidiaries.
- (b) None of Core Pacific-Yamaichi Capital Limited, Conyers Dill & Pearman, Cayman, Greater China Appraisal Limited, Chen & Co. and Deloitte Touche Tohmatsu:
- (i) is interested beneficially or non-beneficially in any shares in any member of the Group; or
  - (ii) has any right or option (whether legally enforceable or not) to subscribe for or to nominate persons to subscribe for any shares in any member of the Group.
- (c) No company within the Group is presently listed on any stock exchange or traded on any trading system.
- (d) All necessary arrangements have been made to enable the Shares to be admitted into CCASS for clearing and settlement.

**DOCUMENTS DELIVERED TO THE REGISTRAR OF COMPANIES**

The documents attached to the copy of this prospectus registered by the Registrar of Companies in Hong Kong were the copies of written consents referred to in the paragraph headed “Consents of experts” under the section headed “Other information” in Appendix IV to this prospectus, copies of the contracts referred to in the paragraph headed “Summary of material contracts” under the section headed “Further information about the business of the Group” in Appendix IV to this prospectus, the statement of adjustments to the accountants’ report set out in Appendix I to this prospectus prepared by Deloitte Touche Tohmatsu and the statement of the particulars of the Vendor including his name, description and address.

**DOCUMENTS AVAILABLE FOR INSPECTION**

Copies of the following documents will be available for inspection at the offices of Sidley Austin Brown & Wood of 49th Floor, Bank of China Tower, 1 Garden Road, Central, Hong Kong during normal business hours up to and including 7th October, 2002:

- (a) the memorandum of association of the Company and the Articles;
- (b) such audited accounts as have been prepared for certain companies comprising the Group for each of the two years ended 31st December, 2001 and seven months ended 31st July, 2002;
- (c) the accountants’ report prepared by Deloitte Touche Tohmatsu, the text of which is set out in Appendix I to this prospectus and the related statement of adjustments;
- (d) the letter, summary of valuation and valuation certificate relating to the properties of the Group prepared by Greater China Appraisal Limited, the text of which is set out in Appendix II to this prospectus;
- (e) the rules of the Share Option Scheme;
- (f) the Companies Law;
- (g) the letter prepared by Conyers Dill & Pearman, Cayman referred to in Appendix III to this prospectus summarising certain aspects of the Cayman Islands company law;
- (h) the service agreements referred to in the paragraph headed “Particulars of service agreements” under the section headed “Further information about directors, management and staff” in Appendix IV to this prospectus;
- (i) the contracts referred to in the paragraph headed “Summary of material contracts” under the section headed “Further information about the business of the Group” in Appendix IV to this prospectus;
- (j) the written consents referred to in the paragraph headed “Consents of experts” under the paragraph headed “Other information” in Appendix IV to this prospectus; and
- (k) the statement of the particulars of the Vendor including his name, description and address.